

M-Max



H-Max



CPX9000



<b>36.1 NFX9000 Drives</b>	
Product Description .....	V6-T36-2
Product Selection .....	V6-T36-3
<b>36.2 M-Max Series Adjustable Frequency AC Drives</b>	
Product Description .....	V6-T36-8
Product Selection .....	V6-T36-9
<b>36.3 SVX9000 Drives</b>	
Product Overview .....	V6-T36-14
SVX9000 Open Drives	
Product Description .....	V6-T36-17
Product Selection .....	V6-T36-19
SVX9000 Enclosed Drives	
Product Description .....	V6-T36-52
Product Selection .....	V6-T36-55
SVX9000 VFD Pump Panels	
Product Description .....	V6-T36-78
Product Selection .....	V6-T36-80
<b>36.4 SPX9000 Drives</b>	
Product Description .....	V6-T36-98
Product Selection .....	V6-T36-101
<b>36.5 H-Max Series Drives</b>	
Product Overview .....	V6-T36-138
H-Max Drives	
Product Description .....	V6-T36-139
Product Selection .....	V6-T36-141
H-Max IntelliPass and IntelliDisconnect Drives	
Product Description .....	V6-T36-149
Product Selection .....	V6-T36-151
<b>36.6 CFX9000 Drives</b>	
Product Description .....	V6-T36-159
Product Selection .....	V6-T36-168
<b>36.7 CPX9000 Drives</b>	
Product Description .....	V6-T36-192
Product Selection .....	V6-T36-200
<b>36.8 LCX9000 Drives</b>	
Product Description .....	V6-T36-222
Product Selection .....	V6-T36-224
<b>36.9 SPA9000/SPN9000/SPI9000 Common DC Bus Drive Products</b>	
Product Description .....	V6-T36-239
Product Selection .....	V6-T36-243



NFX9000 Drives



### Product Description

NFX9000 Adjustable Frequency AC Drives from Eaton’s electrical sector are designed to provide adjustable speed control of three-phase motors. These microprocessor-based drives have standard features that can be programmed to tailor the drive’s performance to suit a wide variety of application requirements.

The NFX9000 volts-per-hertz product line utilizes a 32-bit microprocessor and insulated gate bipolar transistors (IGBTs) which provide quiet motor operation, high motor efficiency and smooth low speed performance. The size and simplicity of the NFX9000 make it ideal for hassle free installation where size is a primary concern.

Models rated at 240 volts, single- or three-phase, 50/60 Hz are available in sizes ranging from 1/4 to 2 hp. Models rated at 115 volts, single-phase, 50/60 Hz are available in the 1/4 to 1/2 hp size range.

The standard drive includes a digital display, operating and programming keys on the keypad.

The display provides drive monitoring as well as adjustment and diagnostic information. The keys are utilized for digital adjustment and programming of the drive as well as for operator control. Separate terminal blocks for control and power wiring are provided for customer connections. The drives feature RS-485 serial communications.

### Contents

<i>Description</i>	<i>Page</i>
NFX9000 Drives	
Catalog Number Selection . . . . .	<b>V6-T36-3</b>
Product Selection . . . . .	<b>V6-T36-3</b>
Technical Data and Specifications . . . . .	<b>V6-T36-4</b>
Wiring Diagrams . . . . .	<b>V6-T36-5</b>
Dimensions . . . . .	<b>V6-T36-7</b>

### Features and Benefits

#### NFX9000 Adjustable Frequency AC Drives

Feature	Customer Benefit
V/Hz control	Provides 150% starting torque and advanced low speed control
Clearly laid out and easy to understand keypad with four-character LED display, four status indicating LEDs, speed potentiometer, and five function keys	Most informative operator’s interface in this class of VFD, provided as standard. All parameters, diagnostic information and metering values are displayed with a bright four-character LED display
One analog input, four programmable, intelligent digital inputs, one programmable relay	Provide enhanced application flexibility
Serial communication port (RS-485)	Direct connection to serial communications networks
Single-phase or three-phase input capability on 115/240 Vac rated units	Operate three-phase motor with single-phase supply

### Standards and Certifications

- NEMA, IEEE, NEC: Design Standards
- UL Listed
- cUL Listed
- CE Marked



## Catalog Number Selection

## NFX9000 Drives

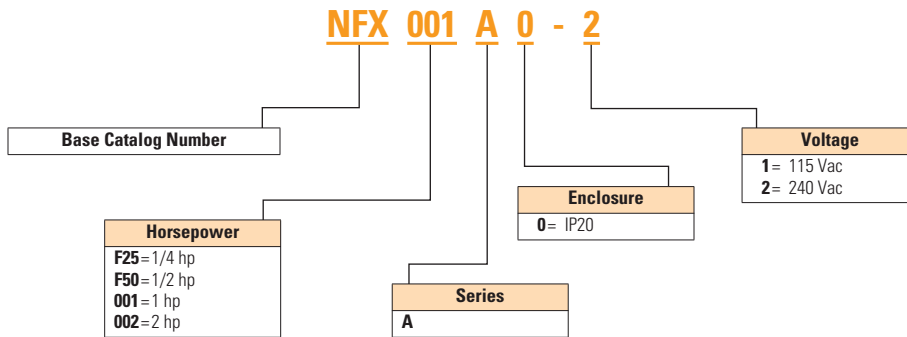

## Product Selection

## NFX9000

## NFX9000 Basic Controller IP20



Description hp <sup>①</sup>	Volts <sup>②</sup>	Input Ampere Single-/Three- Phase Rating	Continuous Output Ampere Rating	Catalog Number
1/4	90–130	6.0/—	1.6	NFXF25A0-1
1/2		9.0/—	2.5	NFXF50A0-1
1/4	200–240	4.9/—	1.6	NFXF25A0-2
1/2		6.5/—	2.5	NFXF50A0-2
1		9.7/—	4.2	NFX001A0-2
2		—/9.0	7	NFX002A0-2

**Notes**

- <sup>①</sup> Horsepower ratings are based on the use of a 240V or 480V NEMA B, four- or six-pole squirrel cage induction motor and are for reference only. Units are to be selected such that the motor current is less than or equal to the NFX9000 rated continuous output current.
- <sup>②</sup> For 208V, 380V or 415V applications, select the unit such that the motor current is less than or equal to the NFX9000 rated continuous output current.

## Technical Data and Specifications

### General Specifications

#### NFX9000 Drives

Description	Specification
<b>Output Ratings</b>	
Horsepower	90V–132V: 1/4–1/2 hp 200–240V: 1/2–2 hp
Frequency range	0.1–400 Hz
Overload rating	150% for 60 seconds
Frequency resolution	Digital: 0.1 Hz
Frequency accuracy	Digital: $\pm 0.01\%$ of max. frequency Analog: $\pm 0.2\%$ of max. frequency
Undervoltage carryover limit	0.3 to 25 seconds
<b>Motor Performance</b>	
Motor control	V/Hz
Constant torque	Standard
Speed regulation	0.5% of base speed
<b>Input Power</b>	
Voltage at 50/60 Hz $\pm 3$ Hz	100V–120V: $-10\%$ $+10\%$ /single-phase 200V–240V: $-10\%$ $+5\%$ /single-phase 200V–240V: $-10\%$ $+5\%$ /three-phase
Displacement power factor	Better than 0.95
Efficiency	Typically greater than 95%
<b>Design Type</b>	
Microprocessor	32-bit
Converter type	Diode
Inverter type	Insulated gate bipolar transistor
Waveform	PWM Volts/Hertz
<b>Environment</b>	
Operating temperature	$-10^{\circ}$ to $40^{\circ}\text{C}$
Humidity	20 to 90% non-condensing
Maximum elevation	1000 meters (3300 ft)
<b>Enclosure</b>	
Standard	Protected chassis (IP20)
<b>Protective Features</b>	
Ground fault	Standard
Overload protection	Standard
Overcurrent	Standard
Overvoltage	Standard
Undervoltage	Standard
Overtemperature	Standard
Overload limit	Standard

### Set Up Adjustments, Performance Features, Operator Control and External Interface

#### Keypad

Description	Specification
Alphanumeric display	Standard, 1 x 4 character
Digital indications	RUN/STOP and FORWARD/REVERSE
Diagnostics	Last three trips with cause
LED status indicators	Four (RUN/STOP and FORWARD/REVERSE)
Operator functions	RUN/STOP, speed control (digital or potentiometer), RESET, MODE keys and ENTER

#### I/O Terminal Block

Description	Specification
Analog inputs	One input: 0–10 Vdc, 4–20 mA Potentiometer: 1 kohm to 2 kohm Analog voltage: Nominal 10 Vdc (10 kohm input impedance) Analog current: Nominal 4–20 mA (250 ohm)
Digital inputs	Four programmable inputs
Digital outputs	One Form A relay contact

#### Programmable Parameters

Description	Specification
Out of the box	Factory settings loaded for quick start-up
Accel. and decel.	2 separately adjustable Linear or S Curve times: 0.1–600 seconds
DC injection braking	①
External fault	Terminal input
Jog	Terminal input
Fault reset	STOP/RESET or terminal input
I/O	NO-NC selectable
Jump frequencies	Three (with adjustable width)
Parameter security	Programmable software lock
Preset speeds	Two preset speeds
Reversing	Keypad or terminal
Speed setting	Keypad, terminal or pot
RUN/STOP control	Keypad or terminal
Stop modes	Decel, coast or DC injection

#### Reliability

Description	Specification
Pretested components	Standard
Surface mount technology	Standard (PCBs)
Computerized testing	Standard
Final test with full load	Standard
Eaton's Engineering Systems and Service	National network of AF drive specialists

#### Note

- ① The motor can be electronically stopped in the shortest possible time, without using an optical external braking resistor.

## Watts Loss

Catalog Number	Horsepower	Volts	Watts Loss 9 kHz
NFXF25A0-1	1/4	115 Vac	20W
NFXF50A0-1	1/2		20W
NFXF25A0-2	1/4	230 Vac	20W
NFXF50A0-2	1/2		20W
NFX001A0-2	1		38W
NFX002A0-2	2		75W

## Wiring Diagrams

## Control Terminal Wiring (Factory Settings)

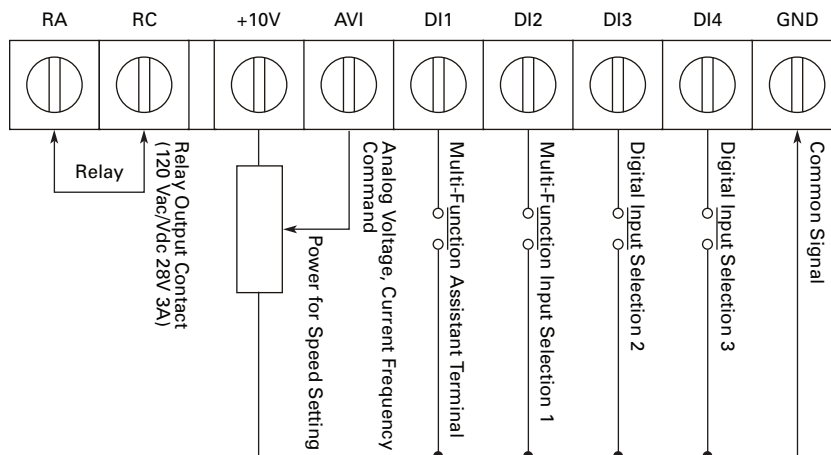

Wire Gauge: 22 – 24 AWG  
Torque: 4 Kgf-cm

#### Basic Wiring Diagram

36

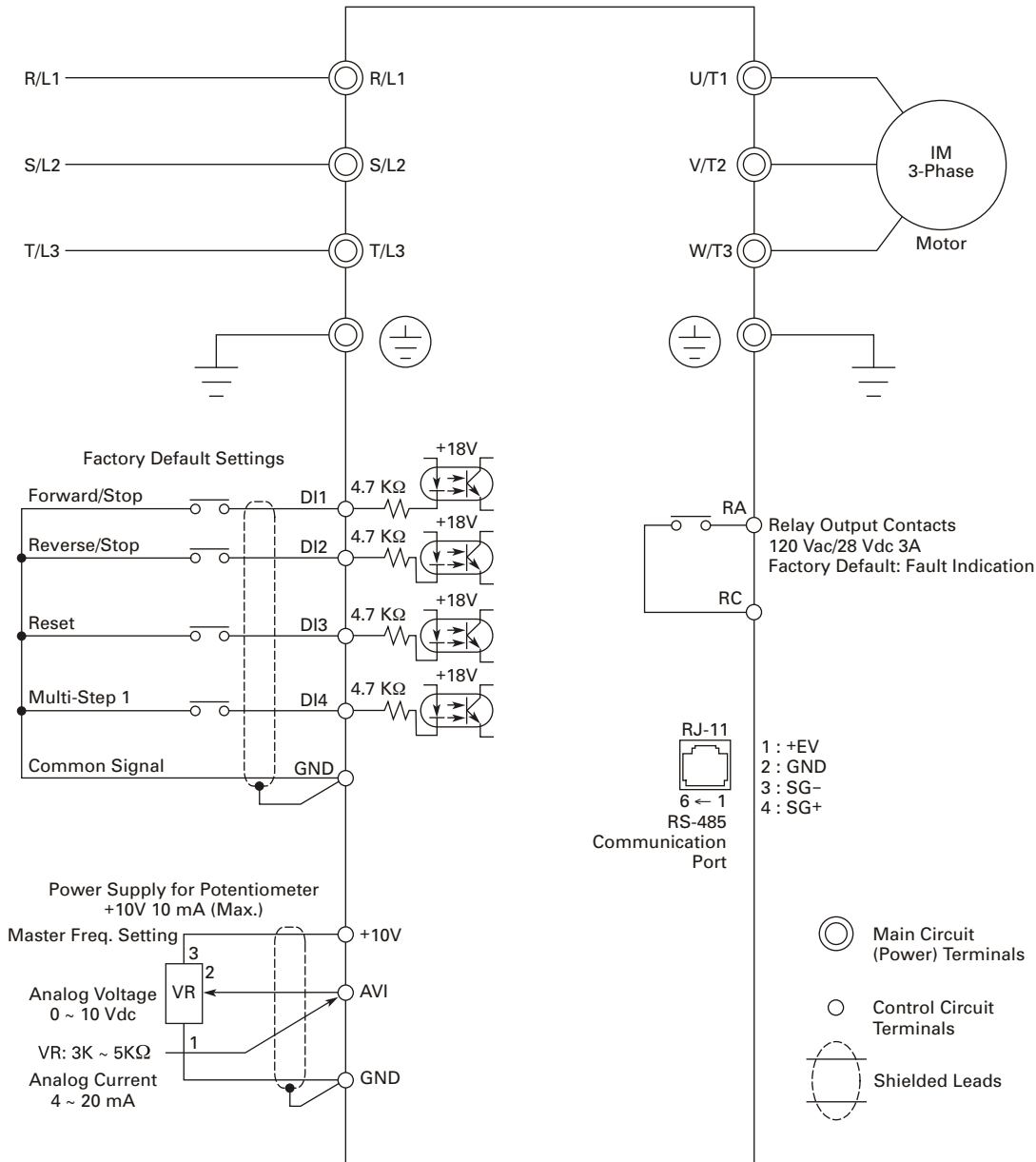

**Note:** Do not plug a modem or telephone line to the RS-485 communication port, permanent damage may result. Terminals 1 and 2 are the power sources for the optional copy keypad and should not be used while using RS-485 communication.

- Use power terminals R/L1 and S/L2 for single-phase connection to models NFXF25A0-1, NFXF50A0-1, NFXF25A0-2, NFXF50A0-2 or NFX001A0-2.
- Use power terminals R/L1, S/L2 and T/L3 for three-phase connection to models NFXF25A0-2, NFXF50A0-2, NFX001A0-2 or NFX002A0-2.
- Single-phase power must not be used for model NFX002A0-2.

## Dimensions

Approximate Dimensions in Inches (mm)

### 1/4 to 2 hp Drive

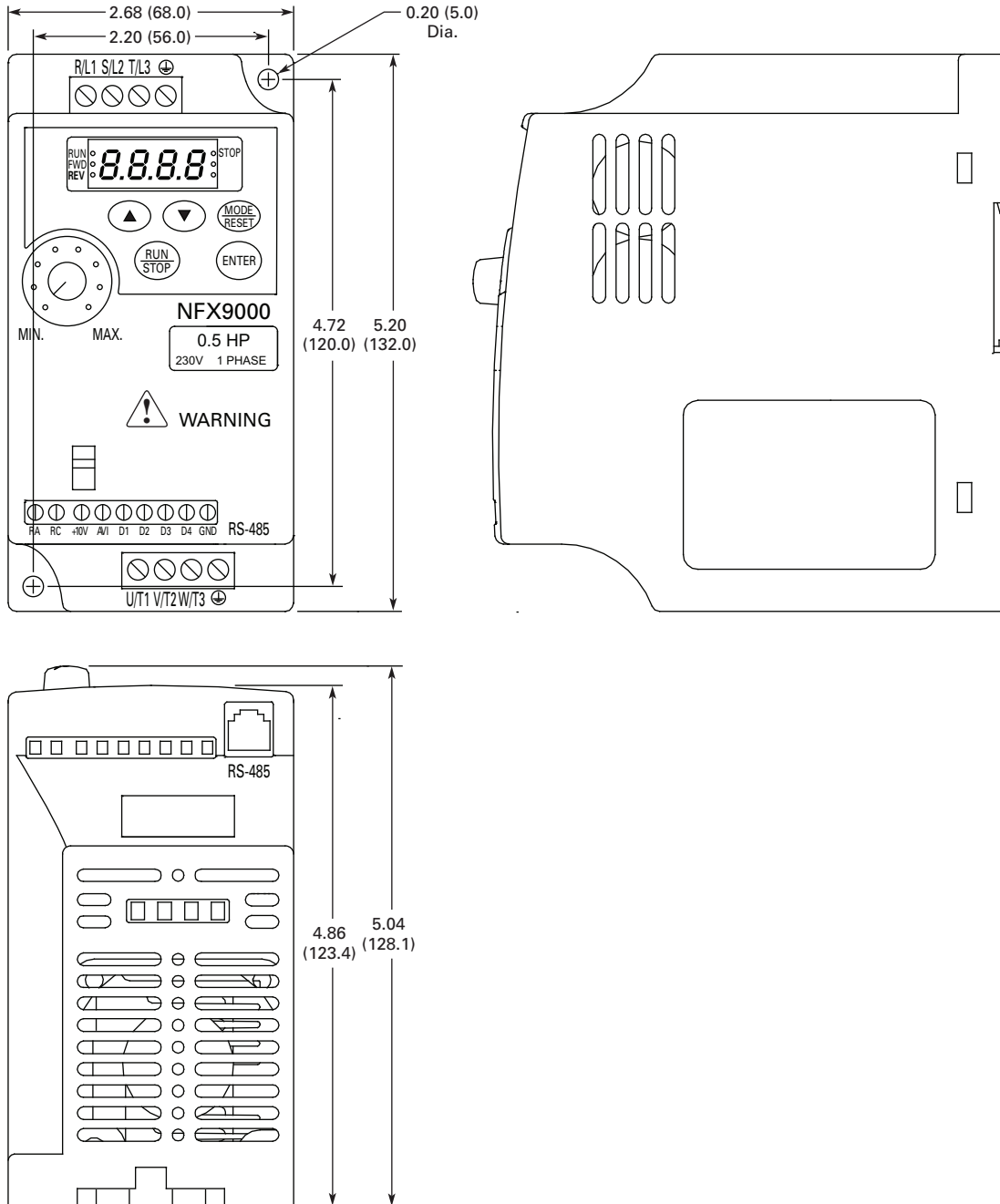

#### M-Max Series Drives for Machinery Applications

36



### Product Description

Eaton's M-Max™ Series Sensorless Vector Adjustable Frequency AC Drives are the next generation of drives specifically engineered for today's machinery applications. These micro-processor-based drives have standard features that can be programmed to tailor the drive's performance to suit a wide variety of application requirements. The M-Max product line uses a 32-bit microprocessor and insulated gate bipolar transistors (IGBTs) that provide quiet motor operation, high motor efficiency, and smooth low-speed performance. The size and simplicity of the M-Max make it ideal for hassle-free installation. Models rated at 575 volts, three-phase, 50/60 Hz are available in sizes ranging from 1 to 7-1/2 hp. Models rated at 480 volts, three-phase, 50/60 Hz are available in sizes ranging from 1/2 to 10 hp. Models rated at 240 volts, single- or three-phase, 50/60 Hz are available in sizes ranging from 1/4 to 3 hp. Models rated at 115 volts, single-phase, 50/60 Hz are available in the 1/4 to 1-1/2 hp size range.

The standard drive includes a digital display, and operating and programming keys on a visually appealing, efficient application programming interface. The display provides drive monitoring, as well as adjustment and diagnostic information. The keys are used for digital adjustment and programming of the drive, as well as for operator control. Separate terminal blocks for control and power wiring are provided for customer connections.

### Contents

<b>Description</b>	<b>Page</b>
M-Max Series Adjustable Frequency AC Drive	
Catalog Number Selection . . . . .	<b>V6-T36-9</b>
Product Selection . . . . .	<b>V6-T36-9</b>
Accessories . . . . .	<b>V6-T36-10</b>
Technical Data and Specifications . . . . .	<b>V6-T36-11</b>
Dimensions . . . . .	<b>V6-T36-13</b>

### Features

- Ease of use—preset application macros, startup wizard, diagnostic capabilities
- Compact, space-saving design
- Rugged and reliable—150% for one minute, 50C rated, conformal coated boards
- DIN rail and screw mountable
- Side-by-side installation
- Industry leading efficiency delivers energy savings to the customer
- Integrated EMC filters make the unit suitable for commercial and industrial networks
- Available in the enclosure class IP20 as standard, options for IP21 and NEMA® 1
- Brake chopper as standard in three-phase, applications of frames 2 (FS2) and larger
- Temperature-controlled fan
- RS-485/Modbus® as standard
- PID controller as standard
- Several fieldbus options

### Standards and Certifications

#### Product

- Complies with EN61800-3 (2004)

#### Safety ①

- 61800-5-1
- EN60204-1
- CE
- UL
- cUL
- IEC
- RoHS compliant

#### EMC (At Default Settings)

- EMC Category C2, C3, and C4 (Level H): With an internal RFI filter option



#### Note

① See unit nameplate for more detailed approvals.



## Catalog Number Selection

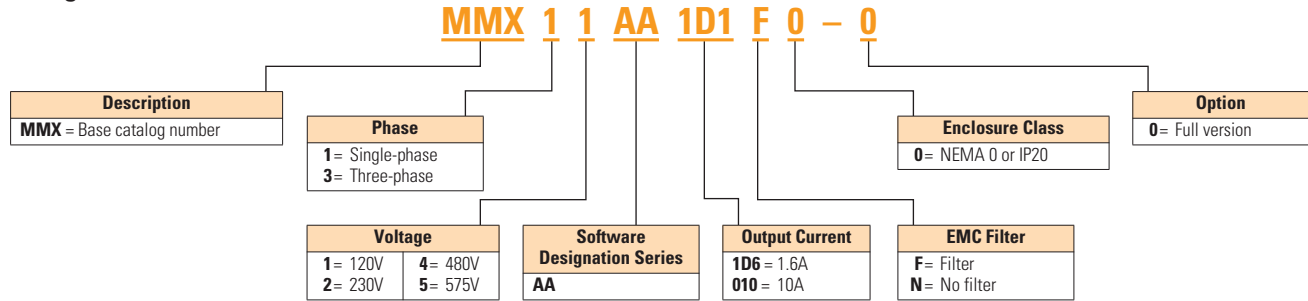

## Product Selection

## M-Max

## M-Max Basic Controller



hp <sup>①</sup>	Volts <sup>②</sup>	100% Continuous Current I <sub>N</sub> (A)	Nominal Input Current (A)	Frame Size	Catalog Number		
1/4	100–120V single-phase in 230V three-phase out	1.7	9.2	FS2	MMX11AA1D7N0-0 <sup>③</sup>		
1/2		2.4	11.6		MMX11AA2D4N0-0 <sup>③</sup>		
3/4		2.8	12.4		MMX11AA2D8N0-0 <sup>③</sup>		
1		3.7	15		MMX11AA3D7N0-0 <sup>③</sup>		
1-1/2		4.8	16.5		MMX11AA4D8N0-0 <sup>③</sup>		
1/4	200–240V single-phase in 230V three-phase out	1.7	4.2	FS1	MMX12AA1D7F0-0		
1/2		2.4	5.7		MMX12AA2D4F0-0		
3/4		2.8	6.6		MMX12AA2D8F0-0		
1		3.7	8.3		MMX12AA3D7F0-0		
1-1/2		4.8	11.2		MMX12AA4D8F0-0		
2		7	14.1		MMX12AA7D0F0-0		
3		9.6	15.8		MMX12AA9D6F0-0		
1/4		200–240V three-phase in 230V three-phase out	1.7		2.7	FS1	MMX32AA1D7N0-0 <sup>③</sup>
1/2			2.4		3.5		MMX32AA2D4N0-0 <sup>③</sup>
3/4			2.8		3.8		MMX32AA2D8N0-0 <sup>③</sup>
1	3.7		4.3	MMX32AA3D7N0-0 <sup>③</sup>			
1-1/2	4.8		6.8	MMX32AA4D8N0-0 <sup>③</sup>			
2	7		8.4	MMX32AA7D0N0-0 <sup>③</sup>			
3	11		13.4	MMX32AA011N0-0 <sup>③</sup>			
1/2	380–480V three-phase in 460V three-phase out	1.3	2.2	FS1	MMX34AA1D3F0-0		
3/4		1.9	2.8		MMX34AA1D9F0-0		
1		2.4	3.2		MMX34AA2D4F0-0		
1-1/2		3.3	4		MMX34AA3D3F0-0		
2		4.3	5.6		MMX34AA4D3F0-0		
3		5.6	7.3		MMX34AA5D6F0-0		
4		7.6	9.6		MMX34AA7D6F0-0		
5		9	11.5		MMX34AA9D0F0-0		
7-1/2		12	14.9		MMX34AA012F0-0		
10		14	18.7		MMX34AA014F0-0		
1		575V three-phase in 575V three-phase out	1.7		2.0	FS3	MMX35AA1D7N0-0 <sup>③</sup>
2			2.7		3.6		MMX35AA2D7N0-0 <sup>③</sup>
3			3.9		5.0		MMX35AA3D9N0-0 <sup>③</sup>
5	6.1		7.6	MMX35AA6D1N0-0 <sup>③</sup>			
7-1/2	9.0		10.4	MMX35AA9D0N0-0 <sup>③</sup>			

## Notes

- ① Horsepower ratings are based on the use of a 240V, 460V, and 575V NEMA B, four- or six-pole squirrel cage induction motor and are for reference only. Units are to be selected such that the motor current is less than or equal to the MMX rated continuous output current.
- ② For 208V, 380V, or 415V applications, select the unit such that the motor current is less than or equal to the MMX rated continuous output current.
- ③ For MMX11\_, MMX32\_, and MMX35\_, there are no options for units with filters.

## Accessories

### M-Max Copy/Paste Module

Description	Catalog Number
Module is plugged onto the front of the drive to provide: upload/download of all parameters, direct link to a PC via USB interface for parameter assignment via MaxConnect software, and copying of parameters for a series of devices or when exchanging devices. No PC required	<b>MMX-COM-PC</b>

### Kits <sup>①</sup>

Description	Catalog Number
Type 1 and IP21 kit for frame 1	<b>MMX-IP21-FS1</b>
Type 1 and IP21 kit for frame 2	<b>MMX-IP21-FS2</b>
Type 1 and IP21 kit for frame 3	<b>MMX-IP21-FS3</b>

### Optional Communication Modules

Description	Catalog Number
Communication adapter kit	<b>MMX-NET-XA</b>
CANopen network card	<b>XXM-NET-CO-A</b>
PROFIBUS DP network card with serial connection	<b>XXM-NET-PS-A</b>
PROFIBUS DP network card with Sub-D connection	<b>XXM-NET-PD-A</b>
DeviceNet network card	<b>XXM-NET-DN-A</b>

### Line Reactors <sup>②</sup>

Description	Catalog Number
<b>3% Line Reactor, Single-Phase</b>	
1/2 hp, 240V	<b>K64-000988-8091</b>
1 hp, 240V	<b>K64-000988-0120</b>
2 hp, 240V	<b>K64-000988-0180</b>
3 hp, 240V	<b>K64-000988-0250</b>
<b>3% Line Reactor, Three-Phase</b>	
1/2 hp, 240V	<b>K64-000989-2091</b>
1 hp, 240V	<b>K64-000989-4091</b>
2 hp, 240V	<b>K64-000989-8091</b>
3 hp, 240V	<b>K64-000989-0120</b>
1 hp, 480V	<b>K64-000989-2091</b>
2 hp, 480V	<b>K64-000989-4091</b>
3 hp, 480V	<b>K64-000989-4091</b>
5 hp, 480V	<b>K64-000989-8091</b>
7-1/2 hp, 480V	<b>K64-000989-0180</b>
10 hp, 480V	<b>K64-000989-0250</b>
1 hp, 575V	<b>K64-000989-2091</b>
2 hp, 575V	<b>K64-000989-8091</b>
3 hp, 575V	<b>K64-000989-8091</b>
5 hp, 575V	<b>K64-000989-4091</b>
7-1/2 hp, 575V	<b>K64-000989-0180</b>
10 hp, 575V	<b>K64-000989-0180</b>

#### Notes

- ① Type 1 kit provides conduit entry plate.
- ② Additional input and output reactors are available. Consult Eaton representative for a complete listing.

## Technical Data and Specifications

### Ratings

#### M-Max Basic Controller IP20 Standard Ratings

Description	Specification
<b>Protections</b>	
Overcurrent protection	Trip limit $4.0 \times I_{H1}$ instantaneously
Overvoltage protection	115/230V series: 437 Vdc; 400V series: 874 Vdc; 575V series: 1048 Vdc trip level
Undervoltage protection	115/230V series: 183 Vdc; 400V series: 333 Vdc; 575V series: 460 Vdc trip level
Ground fault protection	Ground fault is tested before every start. In case of ground fault in motor or motor cable, only the frequency converter is protected
Overtemperature protection	Yes
Motor overload protection	Yes
Motor stall protection	Yes
Motor underload protection	Yes

#### Programmable Parameters

Description
Application macros: basic, pump, fan and high load (hoist)
Programmable start/stop and reverse signal logic (sinking or sourcing)
Reference scaling
Programmable start and stop functions
DC-brake at start and stop
Programmable V/Hz curve
Adjustable switching frequency
Autorestart function after fault
Protections and supervisions (all fully programmable; off, warning, fault)
Current signal input fault
External fault
Fieldbus communication
Eight preset speeds
Analog input range selection, signal scaling and filtering
PID controller
Skip frequencies

### Specifications

#### M-Max Series Drives

Description	Specification
<b>Input Ratings</b>	
Input voltage ( $V_{in}$ )	+10%/–15% (575V units: +15%/–15%)
Input frequency ( $f_{in}$ )	50/60 Hz (variation up to 45–66 Hz)
Connection to power	Once per minute or less (typical operation)
<b>Output Ratings</b>	
Output voltage	0 to $V_{in}$ ①
Continuous output current	Continuous rated current $I_N$ at ambient temperature max. 122°F (50°C), overload $1.5 \times I_N$ max. 1 min/10 min
Output frequency	0 to 320 Hz
Frequency resolution	0.01 Hz
Initial output current ( $I_{H1}$ )	Current $2 \times I_N$ for 2 seconds in every 20-second period Torque depends on motor
<b>Control Characteristics</b>	
Control method	Frequency control (V/Hz) open loop or sensorless vector control
Switching frequency	1.5 to 16 kHz; default 6 kHz
Frequency reference	Analog input: resolution 0.1% (10-bit), accuracy $\pm 1\%$ V/Hz Panel reference: resolution 0.01 Hz
Field weakening point	30 to 320 Hz
Acceleration time	0 to 3000 sec
Deceleration time	0 to 3000 sec
Braking torque	DC brake: $30\% \times T_n$ (without brake option)
<b>Brake Resistor (Minimum Values) ②</b>	
230V Series	FS2 35 ohms and FS3 26 ohms
400V Series	FS2 75 ohms and FS3 54 ohms
575V Series	FS3 103 ohms
<b>Ambient Conditions</b>	
Ambient operating temperature	14°F (–10°C), no frost to 122°F (+50°C): Rated loadability $I_N$
Storage temperature	–40°F (–40°C) to 158°F (70°C)
Relative humidity	0 to 95% RH, noncondensing, non-corrosive, no dripping water
Air quality	Chemical vapors: IEC 721-3-3, unit in operation, Class 3C2; Mechanical particles: IEC 721-3-3, unit in operation, Class 3S2
Altitude	100% load capacity (no derating) up to 3280 ft (1000m); 1% derating for each 328 ft (100m) above 3280 ft (1000m); max. 6560 ft (2000m)
Vibration	EN 60068-2-6; 3 to 150 Hz, displacement amplitude 1 mm (peak) at 3 to 15.8 Hz, max. acceleration amplitude 1G at 15.8 to 150 Hz
Shock	EN 50178, IEC 68-2-27 UPS Drop test (for applicable UPS weights); storage and shipping: max. 15G, 11 ms (in package)
Enclosure class	IP20

#### Notes

① Exception: 115V single-phase in, 230V three-phase out.

② Only three-phase FS2 and FS3 drives are equipped with brake chopper circuit.

#### Standards

36

#### I/O Specifications

- Digital inputs DI1–DI6 are freely programmable. The user can assign multiple functions to a single input
- Digital, relay, and analog outputs are freely programmable

Includes:

- Six digital inputs
- Two analog inputs
  - 4–20 mA
  - 0–10V
- One analog output
- One digital output
- Two relay outputs
- RS-485 interface

#### Reliability

- Pretested components: standard
- Computerized testing: standard
- Final test with full load: standard
- Conformal-coated boards
- 50°C rated
- 150% for one minute/10 mm
- 200% for two seconds/20 sec.
- Eaton Electrical Services and Systems: national network of AF drive specialists

#### M-Max I/O Interface

Terminal	Signal	Factory Preset	Description
1	+10V	—	Ref. output voltage Maximum load 10 mA
2	AI1	Freq. reference <sup>P1</sup>	Analog signal in 1 0–+10V Ri = 200k ohms [min.]
3	GND	—	I/O signal ground
6	24V	—	24V output for DI's ±20%, max. load 50 mA
7	GND	—	I/O signal ground
8	DI1	Start forward <sup>P1</sup>	Digital input 1 0–+30V Ri = 12k ohms min.
9	DI2	Start reverse <sup>P1</sup>	Digital input 2
10	DI3	Preset speed <sup>P1</sup>	Digital input 3
A	A	FB communication	RS-485 signal A
B	B	FB communication	RS-485 signal B
4	AI2	PI actual value <sup>P1</sup>	Analog signal in 2 0[4]–20 mA, Ri = 200k ohms
5	GND	—	I/O signal ground
13	GND	—	I/O signal ground
14	DI4	Preset speed B1 <sup>P1</sup>	Digital input 4 0–+30V Ri = 12k ohms min.
15	DI5	Fault reset <sup>P1</sup>	Digital input 5 0–+30V Ri = 12k ohms min.
16	DI6	Disable PI contr. <sup>P1</sup>	Digital input 6 0–+30V Ri = 12k ohms min.
18	A0	Output frequency <sup>P1</sup>	Analog output 0(2)–10V, RL = 500 ohms
20	DO	Active = READY <sup>P1</sup>	Digital signal out Open collector, max. load 48V/50 mA
22	R011	Relay out 1 Active = RUN <sup>P1</sup>	Max. switching load: 250 Vac/2A or 250 Vdc/0.4A
23	R012		
24	R021	Relay out 2 Active = FAULT <sup>P1</sup>	Max. switching load: 250 Vac/2A or 250 Vdc/0.4A
25	R022		
26	R023		

#### Note

<sup>P1</sup> Parameter-selectable function.

## Dimensions

Approximate Dimensions in Inches (mm)

### M-Max Drives

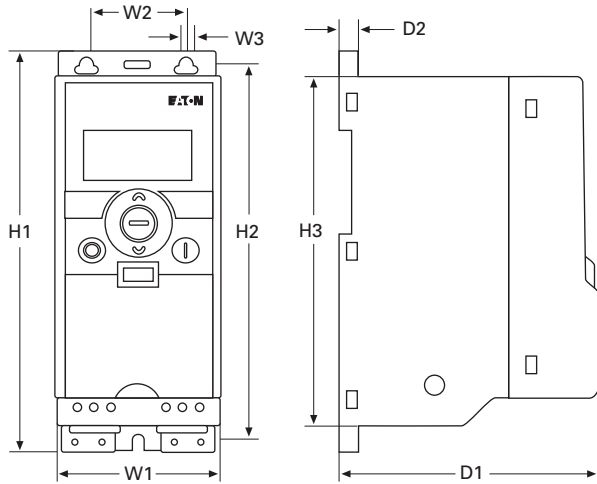

Frame Type	H1	H2	H3	W1	W2	W3	D1	D2	Weight Lbs (kg)
<b>FS1</b>	6.16 (156.5)	5.79 (147.0)	5.40 (137.3)	2.58 (65.5)	1.49 (37.8)	0.17 (4.5)	3.88 (98.5)	0.27 (7.0)	1.213 (0.550)
<b>FS2</b>	7.68 (195.0)	7.20 (183.0)	6.69 (170.0)	3.54 (90.0)	2.46 (62.5)	0.22 (5.5)	4.00 (101.5)	0.27 (7.0)	1.543 (0.699)
<b>FS3</b>	10.33 (262.5)	9.93 (252.3)	9.50 (241.3)	3.94 (100.0)	2.95 (75.0)	0.22 (5.5)	4.27 (108.5)	0.27 (7.0)	2.183 (0.990)

### NEMA 1/IP21 M-Max Drives and Communication Adapter Kit

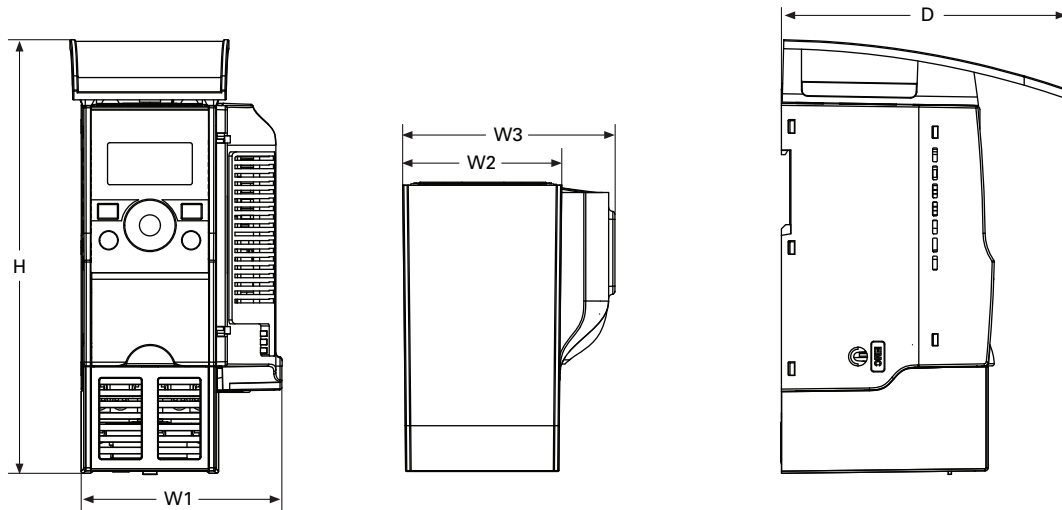

Frame Type	H	W1	W2	W3	D
<b>FS1</b>	8.14 (206.7)	3.77 (95.7)	2.99 (75.9)	3.98 (101.2)	5.41 (137.5)
<b>FS2</b>	9.90 (251.5)	4.72 (120.0)	3.97 (100.8)	4.94 (125.5)	5.68 (144.2)
<b>FS3</b>	12.26 (311.5)	5.12 (130.1)	4.36 (110.8)	5.33 (135.3)	6.32 (160.5)

SVX9000 Drives

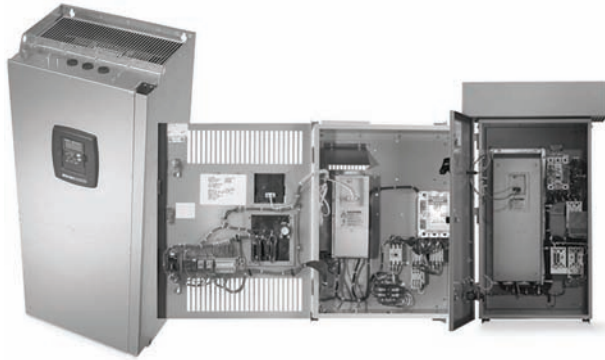

## Product Overview

With the SVX9000 Series Sensorless Vector Control, Eaton's expanded Eaton drive offering now covers a complete line of PWM adjustable frequency (speed) drives in ratings from:

- 208V—3/4 to 100 hp  $I_H$ ;  
1 to 100 hp  $I_L$
- 230V—3/4 to 100 hp  $I_H$ ;  
1 to 125 hp  $I_L$
- 480V—1 to 1900 hp  $I_H$ ;  
1-1/2 to 2200 hp  $I_L$
- 575V—2 to 2000 hp  $I_H$ ;  
3 to 2300 hp  $I_L$

The Eaton family of drives includes HVX9000, H-Max, M-Max, SVX9000, SLX9000 and SPX9000. 9000X Series drive ratings are rated for either high overload ( $I_H$ ) or low overload ( $I_L$ ).  $I_L$  indicates 110% overload capacity for 1 minute out of 10 minutes.  $I_H$  indicates 150% overload capacity for 1 minute out of 10 minutes.

A full range of enclosure types and options are available to meet a wide array of applications—from simple variable torque to more complex industrial applications such as conveyors, mixers and machine controls.

## Application Description

### Application Engineering

Proper selection and application of all drive system components is essential to assure that an adjustable frequency drive system will safely and reliably provide the performance required for any given application. The party responsible for the overall design and operation of the facility must make sure that qualified personnel are employed to select all components of the drive system, including appropriate safety devices. Eaton's AF Drives Application Engineering Department is prepared to provide assistance to answer any questions about the technical capabilities of Eaton drives.

### Motor Selection

The basic requirement of motor selection is to match the torque vs. speed capability of the motor to the torque vs. speed requirement of the driven load.

## Contents

### Description

	<i>Page</i>
SVX9000 Drives	
SVX9000 Open Drives	V6-T36-17
SVX9000 Enclosed Drives	V6-T36-52
SVX9000 VFD Pump Panels	V6-T36-78

### Motor Torque vs. Speed Capability

As the speed of a motor is reduced below its 60 Hz base speed, motor cooling becomes less effective because of the reduced speed of the self-cooling fan. This limitation determines the maximum torque for continuous operation at any operating speed. The maximum intermittent operating torque is determined by the motor's torque vs. current characteristics and the output current capability of the adjustable frequency controller.

### Multiple Motor Operation

A number of motors can be connected in parallel to a single controller. Since the frequency of the power supplied by the controller is the same for each motor, the motors will always operate at the same speed. Application Engineering assistance must be requested for all multiple motor applications to assure compliance with all controller design limitations.

### Special Types of Motors

Standard NEMA Designs A and B three-phase motors are the only motors recommended for use in the majority of applications, but other types of motors are occasionally used. If the existing motor used in the application or the motor proposed for use with the drive system is a type other than NEMA Design A or B, Application Engineering assistance must be requested to make certain that the drive is properly applied.

## Product Selection Guide

### Controller Selection

The basic requirement of controller selection is to match the output current, voltage and frequency capabilities of the controller with the requirements of the connected motor.

#### Output Current

The controller must be selected and applied such that the average operating motor current and horsepower do not exceed the continuous current and horsepower ratings of the controller. The intermittent operating current must not exceed the intermittent current rating of the controller.

#### Motor Protection

Eaton adjustable frequency drives include electronic motor overload protection circuits that are designed to meet the requirements of NEC article 430-2 provided that only one motor is connected to the output of the controller.

#### Output Voltage and Frequency

When they are shipped, AF controllers are adjusted to provide a maximum output voltage and frequency equivalent to the input line voltage and frequency. The controllers can be adjusted to operate above line frequency, but a hazard of personal injury or equipment damage may exist when the motor is operated above base speed. Before adjusting the drive to operate above line frequency, make sure that the motor and the driven machinery can safely be operated at the resulting speed.

## Features

### Controller Features

#### Operator Control and Interface Requirements

Since there are many possible configurations and many ways of achieving a specific end result, it pays to consider the operator control and interface requirements carefully. A simplified and more economical drive package can often be achieved by selecting from standard product offerings rather than specifying a custom designed configuration.

#### Installation Compatibility

The successful application of an AC drive requires the assurance that the drive will be compatible with the environment in which it will be installed. In planning the installation, be sure to carefully consider the heat produced by the drive, the altitude and temperature limits and the need for clean cooling air. Other important considerations include acoustical noise, vibration, electromagnetic compatibility, power quality, controller input harmonic current and power distribution equipment requirements.

#### Auxiliary Equipment and Accessories

Adjustable drives are generally designed to have a motor directly connected to the controller output terminals with no other equipment connected in series or parallel. Motor starters, disconnect switches, surge absorbers, DV/DT suppression circuits, output chokes, output transformers and any other equipment under consideration for installation on the output of the controller should not be installed without first requesting Application Engineering assistance. Power factor correction capacitors must never, under any circumstances, be connected at the output of the controller. They would serve no useful purpose, and they may damage the controller.

#### Enclosure Definitions

- **NEMA Type 1/IP21**—Enclosures are intended for indoor use primarily to provide a degree of protection against contact with enclosed equipment and provide a degree of protection against a limited amount of falling dirt in locations where unusual service conditions do not exist. Top or side openings in the NEMA Type 1/IP21 enclosure allow for the free exchange of inside and outside air while meeting the UL rod entry and rust resistance design tests.
- **NEMA Type 12/IP54**—Enclosures are intended for indoor use primarily to provide a degree of protection against circulating dust, falling dirt and dripping noncorrosive liquids. To meet UL drip, dust and rust resistance tests, NEMA Type 12/IP54 enclosures have no openings to allow for the exchange of inside and outside air.
- **Chassis IP00**—Similar to Protected Chassis IP20 except power terminals are protected by plastic shielding only. Primarily intended to be mounted inside a surrounding protective enclosure.
- **NEMA Type 3R**—Similar in design to NEMA Type 12/IP54 except with more stringent design and test requirements.

## Motor Protection

### *DV/DT and Peak Motor Voltage Solutions*

Today's AFD products offer significantly improved performance, but at the potential cost of motor insulation stress. The fast switching time of the IGBT devices used in newer AFDs can cause a transmission line effect in the output power leads to the motor, leading to possibly damaging voltage levels. To meet this need,

NEMA has introduced a motor in MG1, Part 31, which provides an insulation system designed to maintain normal motor life in AFD applications. For existing motors, a motor protection scheme is required for longer cable runs. Eaton offers three standard solutions for existing systems.

- **MotoRx** This solution provides an energy recovery system which clamps the peak motor voltage to a safe level for standard motors. This option is used when the distance between a single motor and the drive is 600 ft or less.

- **Output Line Reactor** This option provides an output line reactor, reducing the DV/DT of the AFD output voltage and lessening the transmission line effect, to lower the peak voltage at the motor terminals.

### Product Availability Codes

The product availability codes indicate the type of facility (warehouse, Mod Center or factory) that the product will ship from and, if it is not in stock, the number of working days needed to assemble the

product from receipt of the order to shipment from the designated facility. Please note that this lead-time does not include any in-transit time from our facility to your facility.

### Product Availability Codes

Code	Description
W	Warehouse stocked item. Shipped on customer request date. If item is backordered, please check Vista/VISTALINE or contact your Customer Support Center for product availability.
F1	Factory assemble-to-order. Shipped from factory within 1 working day after receipt of order on Vista.
FA	Factory assemble-to-order. Shipped from factory within 2–3 working days after receipt of order on Vista.
FB	Factory assemble-to-order. Shipped from factory within 4–10 working days after receipt of order on Vista.
FC	Factory assemble-to-order. Shipped from factory within 11–15 working days after receipt of order on Vista.
FD	Factory assemble-to-order. Shipped from factory within 16–20 working days after receipt of order on Vista.
FP	Factory assemble-to-order. Shipped from factory on negotiated promise date.
MA	Mod Center assemble-to-order. Shipped from Mod Center within 1–3 working days after receipt of order on Vista.
MB	Mod Center assemble-to-order. Shipped from Mod Center within 4–10 working days after receipt of order on Vista.
MP	Mod Center assemble-to-order. Shipped from Mod Center on negotiated promise date.

Product availability codes contained herein for a given product may be quantity sensitive and are subject to change without notice.

For the most current information, refer to the Product Identification Inquiry (PIN) screen on Vista.



## SVX9000 Open Drives



## SVX9000 Open Drives

## Product Description

SVX9000 Series Adjustable Frequency Drives from Eaton's electrical sector are the next generation of drives specifically engineered for today's commercial and industrial applications. The power unit makes use of the most sophisticated semiconductor technology and a highly modular construction that can be flexibly adapted to the customer's needs.

The input and output configuration (I/O) is designed with modularity in mind. The I/O is comprised of option cards, each with its own input and output configuration. The control module is designed to accept a total of five of these cards. The cards contain not only normal analog and digital inputs but also fieldbus cards.

These drives continue the tradition of robust performance, and raise the bar on features and functionality, ensuring the best solution at the right price.

## Features

- Robust design—proven 500,000 hours MTBF
- Integrated 3% line reactors standard on drives from FR4 through FR9
- EMI/RFI Filters H standard up to 200 hp I<sub>H</sub> 480V, 100 hp I<sub>H</sub> 230V
- Simplified operating menu allows for typical programming changes, while programming mode provides control of everything
- Quick Start Wizard built into the programming of the drive ensures a smooth start-up
- Keypad can display up to three monitored parameters simultaneously
- LOCAL/REMOTE operation from keypad
- Copy/paste function allows transfer of parameter settings from one drive to the next
- Standard NEMA Type 12/ IP54 keypad on all drives
- The SVX can be flexibly adapted to a variety of needs using our pre-installed "Seven in One" precision application programs consisting of:
  - Basic
  - Standard
  - Local/remote
  - Multi step speed control
  - PID control
  - Multi-purpose control
  - Pump and fan control with auto change
- Additional I/O and communication cards provide plug and play functionality
- I/O connections with simple quick connection terminals
- Hand-held auxiliary 24V power supply allows programming/monitoring of control module without applying full power to the drive
- Control logic can be powered from an external auxiliary control panel, internal drive functions and fieldbus if necessary
- Brake chopper standard from: 1–30 hp/380–500V 3/4–15 hp/208–230V
- NEMA Type 1/IP21 and NEMA Type 12/IP54 enclosures available, Frame Sizes FR4–FR9
- Open chassis FR10 and greater
- Standard option board configuration includes an A9 I/O board and an A2 relay output board installed in slots A and B

## Contents

## Description

## Page

SVX9000 Open Drives	
Standards and Certifications . . . . .	V6-T36-18
Catalog Number Selection . . . . .	V6-T36-18
Product Selection . . . . .	V6-T36-19
Accessories . . . . .	V6-T36-23
Options . . . . .	V6-T36-24
Replacement Parts . . . . .	V6-T36-27
Technical Data and Specifications . . . . .	V6-T36-34
Dimensions . . . . .	V6-T36-35
SVX9000 Enclosed Drives . . . . .	V6-T36-52
SVX9000 VFD Pump Panels . . . . .	V6-T36-78

# 36.3

## Adjustable Frequency Drives

### SVX9000 Drives

36

#### Standards and Certifications

##### Product

- IEC 61800-2

##### EMC (At Default Settings)

- Immunity: Fulfills all EMC immunity requirements;
- Emissions: EN 61800-3, LEVEL H

##### Safety

- UL 508C



#### Catalog Number Selection

##### SVX9000 Adjustable Frequency Drives

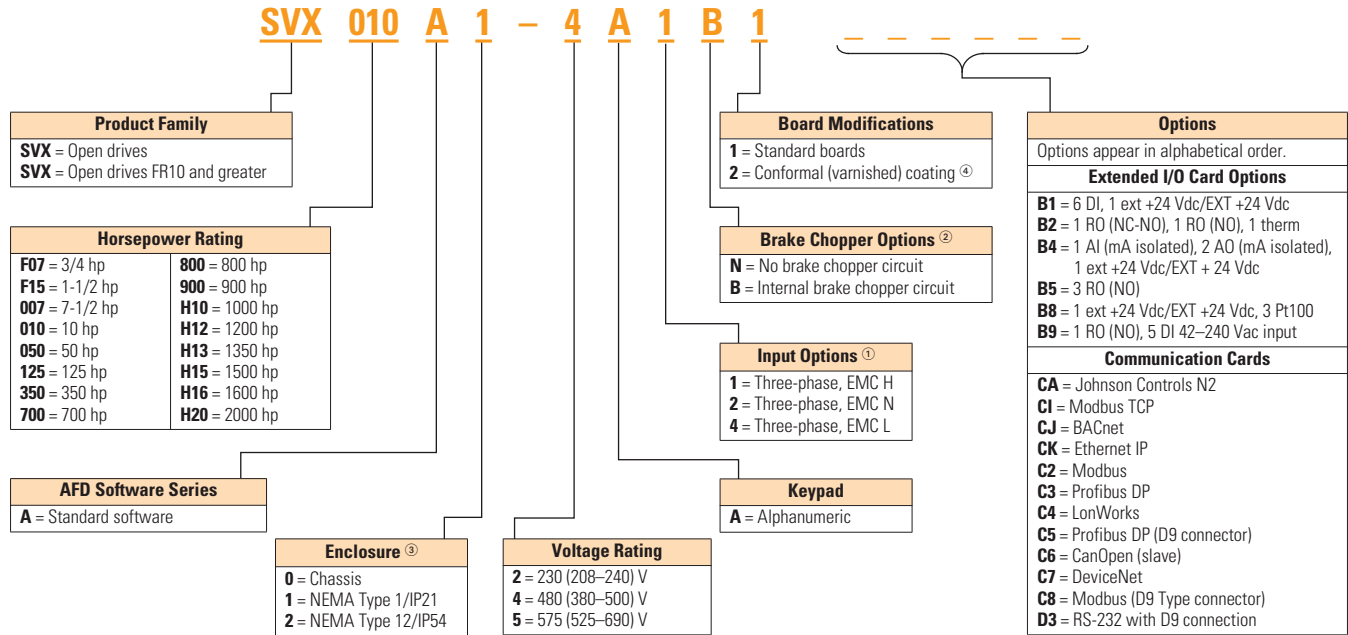

#### Power Module

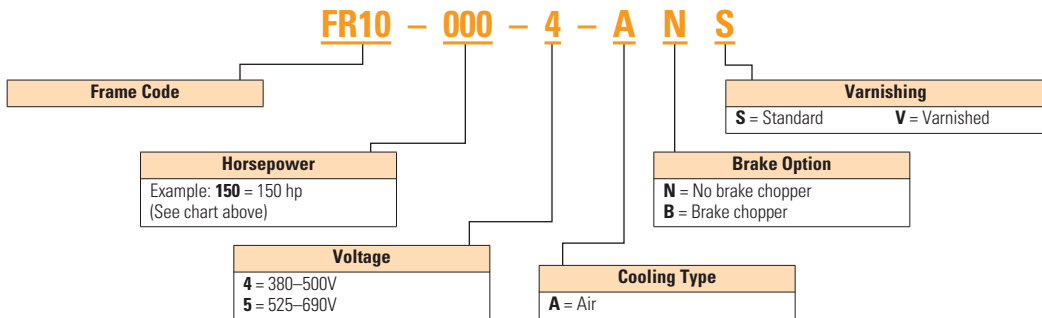

#### Notes

- All 230V drives and 480V drives up to 200 hp (IH) are only available with input option 1 (EMC Level H). 480V drives 250 hp (IH) or larger are available with input option 2 (EMC Level N). 480V drives are available with input option 4 (EMC Level L). 575V drives 200 hp (IH) or larger are only available with input option 2. 575V drives up to 150 hp (IH) are only available with input option 4 (EMC Level L).
- 480V drives up to 30 hp (IH) are only available with brake chopper option B. 480V drives 40 hp (IH) or larger come standard with brake chopper option N. 230V drives up to 15 hp (IH) are only available with brake chopper option B. 230V drives 20 hp or larger come standard with brake chopper option N. All 575V drives come standard without brake chopper option (N). N = No brake chopper.
- 480V drives 250 hp (IH) and larger are available with enclosure style 0 (chassis); 690V drives 200 hp (IH) and larger are available with enclosure style 0 (chassis).
- Factory promise delivery. Consult sales office for availability.

## Product Selection

## 230V SVX9000 Drives

## SVX9000 Open Drives



## 208–240V, NEMA Type 1/IP21 Drives

Frame Size	Delivery Code	hp (I <sub>H</sub> )	Current (I <sub>H</sub> )	hp (I <sub>L</sub> )	Current (I <sub>L</sub> )	Catalog Number
FR4	W	3/4	3.7	1	4.8	SVXF07A1-2A1B1
		1	4.8	1-1/2	6.6	SVX001A1-2A1B1
		1-1/2	6.6	2	7.8	SVXF15A1-2A1B1
		2	7.8	3	11	SVX002A1-2A1B1
		3	11	—	12.5	SVX003A1-2A1B1
FR5	W	—	12.5	5	17.5	SVX004A1-2A1B1
		5	17.5	7-1/2	25	SVX005A1-2A1B1
		7-1/2	25	10	31	SVX007A1-2A1B1
FR6	W	10	31	15	48	SVX010A1-2A1B1
		15	48	20	61	SVX015A1-2A1B1
FR7	W	20	61	25	75	SVX020A1-2A1N1
		25	75	30	88	SVX025A1-2A1N1
		30	88	40	114	SVX030A1-2A1N1
FR8	W	40	114	50	140	SVX040A1-2A1N1
		50	140	60	170	SVX050A1-2A1N1
		60	170	75	205	SVX060A1-2A1N1
FR9	W	75	205	100	261	SVX075A1-2A1N1
		100	261	125	300	SVX100A1-2A1N1

## 208–240V, NEMA Type 12/IP54 Drives

Frame Size	Delivery Code	hp (I <sub>H</sub> )	Current (I <sub>H</sub> )	hp (I <sub>L</sub> )	Current (I <sub>L</sub> )	Catalog Number
FR4	F1	3/4	3.7	1	4.8	SVXF07A2-2A1B1
		1	4.8	1-1/2	6.6	SVX001A2-2A1B1
		1-1/2	6.6	2	7.8	SVXF15A2-2A1B1
		2	7.8	3	11	SVX002A2-2A1B1
		3	11	—	12.5	SVX003A2-2A1B1
FR5	F1	—	12.5	5	17.5	SVX004A2-2A1B1
		5	17.5	7-1/2	25	SVX005A2-2A1B1
		7-1/2	25	10	31	SVX007A2-2A1B1
FR6	F1	10	31	15	48	SVX010A2-2A1B1
		15	48	20	61	SVX015A2-2A1B1
FR7	W	20	61	25	75	SVX020A2-2A1N1
		25	75	30	88	SVX025A2-2A1N1
		30	88	40	114	SVX030A2-2A1N1
FR8	FP	40	114	50	140	SVX040A2-2A1N1
		50	140	60	170	SVX050A2-2A1N1
		60	170	75	205	SVX060A2-2A1N1
FR9	FP	75	205	100	261	SVX075A2-2A1N1
		100	261	125	300	SVX100A2-2A1N1

## 480V SVX9000 Drives

36

## SVX9000 Open Drives



## 380–500V, NEMA Type 1/IP21 Drives

Frame Size	Delivery Code	hp (I <sub>H</sub> )	Current (I <sub>H</sub> )	hp (I <sub>L</sub> )	Current (I <sub>L</sub> )	Catalog Number
FR4	W	1	2.2	1-1/2	3.3	SVX001A1-4A1B1
		1-1/2	3.3	2	4.3	SVXF15A1-4A1B1
		2	4.3	3	5.6	SVX002A1-4A1B1
		3	5.6	5	7.6	SVX003A1-4A1B1
		5	7.6	—	9	SVX005A1-4A1B1
		—	9	7-1/2	12	SVX006A1-4A1B1
FR5	W	7-1/2	12	10	16	SVX007A1-4A1B1
		10	16	15	23	SVX010A1-4A1B1
		15	23	20	31	SVX015A1-4A1B1
FR6	W	20	31	25	38	SVX020A1-4A1B1
		25	38	30	46	SVX025A1-4A1B1
		30	46	40	61	SVX030A1-4A1B1
FR7	W	40	61	50	72	SVX040A1-4A1N1
		50	72	60	87	SVX050A1-4A1N1
		60	87	75	105	SVX060A1-4A1N1
FR8	W	75	105	100	140	SVX075A1-4A1N1
		100	140	125	170	SVX100A1-4A1N1
		125	170	150	205	SVX125A1-4A1N1
FR9	W	150	205	200	261	SVX150A1-4A1N1
		200	245	250	300	SVX200A1-4A1N1

## 380–500V, NEMA Type 12/IP54 Drives

Frame Size	Delivery Code	hp (I <sub>H</sub> )	Current (I <sub>H</sub> )	hp (I <sub>L</sub> )	Current (I <sub>L</sub> )	Catalog Number
FR4	F1	1	2.2	1-1/2	3.3	SVX001A2-4A1B1
		1-1/2	3.3	2	4.3	SVXF15A2-4A1B1
		2	4.3	3	5.6	SVX002A2-4A1B1
		3	5.6	5	7.6	SVX003A2-4A1B1
		5	7.6	—	9	SVX005A2-4A1B1
		—	9	7-1/2	12	SVX006A2-4A1B1
FR5	F1	7-1/2	12	10	16	SVX007A2-4A1B1
		10	16	15	23	SVX010A2-4A1B1
		15	23	20	31	SVX015A2-4A1B1
FR6	F1	20	31	25	38	SVX020A2-4A1B1
		25	38	30	46	SVX025A2-4A1B1
		30	46	40	61	SVX030A2-4A1B1
FR7	W	40	61	50	72	SVX040A2-4A1N1
		50	72	60	87	SVX050A2-4A1N1
		60	87	75	105	SVX060A2-4A1N1
FR8	W	75	105	100	140	SVX075A2-4A1N1
		100	140	125	170	SVX100A2-4A1N1
		125	170	150	205	SVX125A2-4A1N1
FR9	W	150	205	200	261	SVX150A2-4A1N1
		200	245	250	300	SVX200A2-4A1N1

## SVX9000 Open Drives



## 380–500V, Open Chassis Drives

Frame Size	Delivery Code	hp (I <sub>H</sub> )	Current (I <sub>H</sub> )	hp (I <sub>L</sub> )	Current (I <sub>L</sub> )	Catalog Number
FR10 <sup>Ⓢ</sup>	W	250	330	300	385	SPX250A0-4A2N1
		300	385	350	460	SPX300A0-4A2N1
		350	460	400	520	SPX350A0-4A2N1
FR11	W	400	520	500	590	SPX400A0-4A2N1
		500	590	—	650	SPX500A0-4A2N1
		—	650	600	730	SPX550A0-4A2N1
FR12	FP	600	730	—	820	SPX600A0-4A2N1
	W	—	820	700	920	SPX650A0-4A2N1
	FP	700	920	800	1030	SPX700A0-4A2N1
FR13	FP	800	1030	900	1150	SPX800A0-4A2N1
		900	1150	1000	1300	SPX900A0-4A2N1
		1000	1300	1200	1450	SPXH10A0-4A2N1
FR14	FP	1200	1600	1500	1770	SPXH12A0-4A2N1
		1600	1940	1800	2150	SPXH16A0-4A2N1
		1900	2300	2200	2700	SPXH19A0-4A2N1

## 575V SVX9000 Drives

## 525–690V, NEMA Type 1/IP21 Drives

Frame Size	Delivery Code	hp (I <sub>H</sub> )	Current (I <sub>H</sub> )	hp (I <sub>L</sub> )	Current (I <sub>L</sub> )	Catalog Number
FR6	W	2	3.3	3	4.5	SVX002A1-5A4N1
		3	4.5	—	5.5	SVX003A1-5A4N1
		—	5.5	5	7.5	SVX004A1-5A4N1
		5	7.5	7-1/2	10	SVX005A1-5A4N1
		7-1/2	10	10	13.5	SVX007A1-5A4N1
		10	13.5	15	18	SVX010A1-5A4N1
		15	18	20	22	SVX015A1-5A4N1
		20	22	25	27	SVX020A1-5A4N1
		25	27	30	34	SVX025A1-5A4N1
FR7	W	30	34	40	41	SVX030A1-5A4N1
		40	41	50	52	SVX040A1-5A4N1
FR8	W	50	52	60	62	SVX050A1-5A4N1
		60	62	75	80	SVX060A1-5A4N1
		75	80	100	100	SVX075A1-5A4N1
FR9	W	100	100	125	125	SVX100A1-5A4N1
		125	125	150	144	SVX125A1-5A4N1
		150	144	—	170	SVX150A1-5A4N1
		—	170	200	208	SVX175A1-5A4N1

**Note**

<sup>Ⓢ</sup> FR10–FR14 includes 3% line reactor, but it is not integral to chassis.

#### SVX9000 Open Drives

#### 525–690V, NEMA Type 12/IP54 Drives

Frame Size	Delivery Code	hp (I <sub>H</sub> )	Current (I <sub>H</sub> )	hp (I <sub>L</sub> )	Current (I <sub>L</sub> )	Catalog Number
FR6	F1	2	3.3	3	4.5	SVX002A2-5A4N1
		3	4.5	—	5.5	SVX003A2-5A4N1
		—	5.5	5	7.5	SVX004A2-5A4N1
		5	7.5	7-1/2	10	SVX005A2-5A4N1
		7-1/2	10	10	13.5	SVX007A2-5A4N1
		10	13.5	15	18	SVX010A2-5A4N1
		15	18	20	22	SVX015A2-5A4N1
		20	22	25	27	SVX020A2-5A4N1
FR7	FP	30	34	40	41	SVX030A2-5A4N1
		40	41	50	52	SVX040A2-5A4N1
FR8	FP	50	52	60	62	SVX050A2-5A4N1
		60	62	75	80	SVX060A2-5A4N1
		75	80	100	100	SVX075A2-5A4N1
FR9	FP	100	100	125	125	SVX100A2-5A4N1
		125	125	150	144	SVX125A2-5A4N1
		150	144	—	170	SVX150A2-5A4N1
		—	170	200	208	SVX175A2-5A4N1

#### 525–690V, Open Chassis Drives

Frame Size	Delivery Code	hp (I <sub>H</sub> )	Current (I <sub>H</sub> )	hp (I <sub>L</sub> )	Current (I <sub>L</sub> )	Catalog Number
FR10	FP	200	208	250	261	SPX200A0-5A2N1
		250	261	300	325	SPX250A0-5A2N1
		300	325	400	385	SPX300A0-5A2N1
FR11	FP	400	385	450	460	SPX400A0-5A2N1
		450	460	500	502	SPX450A0-5A2N1
		500	502	—	590	SPX500A0-5A2N1
FR12	FP	—	590	600	650	SPX550A0-5A2N1
		600	650	700	750	SPX600A0-5A2N1
		700	750	800	820	SPX700A0-5A2N1
FR13	FP	800	820	900	920	SPX800A0-5A2N1
		900	920	1000	1030	SPX900A0-5A2N1
		1000	1030	1250	1180	SPXH10A0-5A2N1
FR14	FP	1350	1300	1500	1500	SPXH13A0-5A2N1
		1500	1500	2000	1900	SPXH15A0-5A2N1
		2000	1900	2300	2250	SPXH20A0-5A2N1

## Accessories

### Demo Drive and Power Supply

#### Demo Drive and Power Supply

Description	Catalog Number
9000X demo drive	9000XDEMO
Hand-held 24V auxiliary power supply—Used to supply power to the control module in order to perform keypad programming before the drive is connected to line voltage	9000XAUX24V

#### NEMA Type 12/IP54 Conversion Kit

The NEMA Type 12/IP54 kit option is used to convert a NEMA Type 1/IP21 to a NEMA Type 12/IP54 drive. The NEMA Type 12/IP54 kit consists of a metal drive shroud, fan kit for some frames, adaptor plate and plugs.

#### NEMA Type 12/IP54 Conversion Kit

Frame Size	Delivery Code	Approximate Dimensions in Inches (mm)			Approximate Weight Lb (kg)	Catalog Number
		Length	Width	Height		
FR4	W	13 (330)	7 (178)	4 (102)	4 (1.8)	OPTN12FR4
FR5		16 (406)	8 (203)	7 (178)	5 (2.3)	OPTN12FR5
FR6		21 (533)	10 (254)	5 (127)	7 (3.2)	OPTN12FR6

### Flange Kits

#### Flange Kit NEMA Type 12/IP54

The flange kit is utilized when the power section is mounted through the back panel of an enclosure. Includes flange mount brackets and NEMA Type 12/IP54 fan components. Metal shroud not included.

Flange kits for NEMA Type 12/IP54 enclosure drive rating are determined by rating of drive.

#### Flange Kit NEMA Type 12/IP54—Frames 4, 5 and 6<sup>①</sup>

Frame Size	Delivery Code	Catalog Number
FR4	W	OPTTHRFR4
FR5		OPTTHRFR5
FR6		OPTTHRFR6

#### Flange Kit NEMA Type 12/IP54—Frames 4–9<sup>①</sup>

Frame Size	Delivery Code	Catalog Number
FR4	FP	OPTTHR4
FR5		OPTTHR5
FR6		OPTTHR6
FR7		OPTTHR7
FR8		OPTTHR8
FR9		OPTTHR9

#### Flange Kit NEMA Type 1/IP21

Flange kits for NEMA Type 1/IP21 enclosure drive rating are determined by rating of drive.

#### Flange Kit NEMA Type 1/IP21—Frames 4–9<sup>①</sup>

Frame Size	Delivery Code	Catalog Number
FR4	FP	OPTTHR4
FR5		OPTTHR5
FR6		OPTTHR6
FR7		OPTTHR7
FR8		OPTTHR8
FR9		OPTTHR9

#### Note

<sup>①</sup> For installation of an SVX9000 NEMA Type 1/IP21 drive into a NEMA Type 12/IP54 oversized enclosure.

#### Options

##### 9000X Series Option Board Kits

36

The 9000X Series drives can accommodate a wide selection of expander and adapter option boards to customize the drive for your application needs. The drive's control unit is designed to accept a total of five option boards.

The 9000X Series factory installed standard board configuration includes an A9 I/O board and an A2 relay output board, which are installed in slots A and B.

#### Option Boards

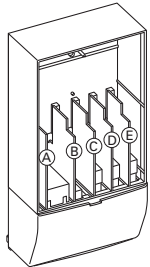

#### Option Board Kits

Option Kit Description <sup>①</sup>	Allowed Slot Locations <sup>②</sup>	Field Installed Catalog Number	Factory Installed Option Designator	SVX Ready Programs						
				Basic	Local/Remote	Standard	MSS	PID	Multi-P.	PFC
<b>Standard I/O Cards</b>										
2 RO (NC-NO)	B	<b>OPTA2</b>	—	■	■	■	■	■	■	■
6 DI, 1 DO, 2 AI, 1 AO, 1 +10 Vdc ref, 2 ext +24 Vdc/EXT +24 Vdc	A	<b>OPTA9</b>	—	■	■	■	■	■	■	■
<b>Extended I/O Cards</b>										
2 RO, therm—SPX only	B	<b>OPTA3</b>	<b>A3</b>	—	■	■	■	■	■	■
Encoder low volt +5V/15V/24V—SPX only	C	<b>OPTA4</b>	<b>A4</b>	—	■	■	■	■	■	■
Encoder high volt +15V/24V—SPX only	C	<b>OPTA5</b>	<b>A5</b>	—	■	■	■	■	■	■
Double encoder—SPX only	C	<b>OPTA7</b>	<b>A7</b>	■	■	■	■	■	■	■
6 DI, 1 DO, 2 AI, 1 AO—SPX only	A	<b>OPTA8</b>	<b>A8</b>	—	■	■	■	■	■	■
3 DI (encoder 10–24V), out +15V/+24V, 2 DO (pulse+direction)—SPX only	C	<b>OPTAE</b>	<b>AE</b>	■	■	■	■	■	■	■
6 DI, 1 ext +24 Vdc/EXT +24 Vdc	B, C, <b>D</b> , E	<b>OPTB1</b>	<b>B1</b>	—	—	—	—	—	■	■
1 RO (NC-NO), 1 RO (NO), 1 therm	B, C, <b>D</b> , E	<b>OPTB2</b>	<b>B2</b>	—	—	—	—	—	■	■
1 AI (mA isolated), 2 AO (mA isolated), 1 ext +24 Vdc/EXT +24 Vdc	B, C, <b>D</b> , E	<b>OPTB4</b>	<b>B4</b>	■	■	■	■	■	■	■
3 RO (NO)	B, C, <b>D</b> , E	<b>OPTB5</b>	<b>B5</b>	—	—	—	—	—	■	■
1 ext +24 Vdc/EXT +24 Vdc, 3 Pt100	B, C, <b>D</b> , E	<b>OPTB8</b>	<b>B8</b>	—	—	—	—	—	—	—
1 RO (NO), 5 DI 42–240 Vac input	B, C, <b>D</b> , E	<b>OPTB9</b>	<b>B9</b>	—	—	—	—	—	■	■
<b>Communication Cards</b>										
Modbus <sup>③</sup>	D, <b>E</b>	<b>OPTC2</b>	<b>C2</b>	■	■	■	■	■	■	■
Johnson Controls N2 <sup>③</sup>	D, <b>E</b>	<b>OPTC2</b>	<b>CA</b>	—	—	—	—	—	—	—
Modbus TCP	D, <b>E</b>	<b>OPTCI</b>	<b>CI</b>	■	■	■	■	■	■	■
BACnet	D, <b>E</b>	<b>OPTCJ</b>	<b>CJ</b>	■	■	■	■	■	■	■
Ethernet IP	D, <b>E</b>	<b>OPTCK</b>	<b>CK</b>	■	■	■	■	■	■	■
Profibus DP	D, <b>E</b>	<b>OPTC3</b>	<b>C3</b>	■	■	■	■	■	■	■
LonWorks	D, <b>E</b>	<b>OPTC4</b>	<b>C4</b>	■	■	■	■	■	■	■
Profibus DP (D9 connector)	D, <b>E</b>	<b>OPTC5</b>	<b>C5</b>	■	■	■	■	■	■	■
CanOpen (slave) <sup>④</sup>	D, <b>E</b>	<b>OPTC6</b>	<b>C6</b>	■	■	■	■	■	■	■
DeviceNet	D, <b>E</b>	<b>OPTC7</b>	<b>C7</b>	■	■	■	■	■	■	■
Modbus (D9 type connector)	D, <b>E</b>	<b>OPTC8</b>	<b>C8</b>	■	■	■	■	■	■	■
Adapter—SPX only	D, <b>E</b>	<b>OPTD1</b>	<b>D1</b>	■	■	■	■	■	■	■
Adapter—SPX only	D, <b>E</b>	<b>OPTD2</b>	<b>D2</b>	■	■	■	■	■	■	■
RS-232 with D9 connection	D, <b>E</b>	<b>OPTD3</b>	<b>D3</b>	■	■	■	■	■	■	■
<b>Keypad</b>										
9000X Series local/remote keypad (replacement keypad)	—	<b>KEYPAD-LOC/REM</b>	—	—	—	—	—	—	—	—
9000X Series remote mount keypad unit (keypad not included, includes 10 ft cable, keypad holder, mounting hardware)	—	<b>OPTRMT-KIT-9000X</b>	—	—	—	—	—	—	—	—
9000X Series RS-232 cable, 13 ft	—	<b>PP00104</b>	—	—	—	—	—	—	—	—

#### Notes

- ① AI = Analog Input; AO = Analog Output, DI = Digital Input, DO = Digital Output, RO = Relay Output
- ② Option card must be installed in one of the slots listed for that card. Slot indicated in bold is the preferred location.
- ③ OPTC2 is a multi-protocol option card.
- ④ SPX9000 drives only (FR10 and larger).



**Modbus RTU Network Communications**

The Modbus Network Card OPTC2 is used for connecting the 9000X Drive as a slave on a Modbus network. The interface is connected by a 9-pin DSUB connector (female) and the baud rate ranges from 300 to 19200 baud. Other communication parameters include an address range from 1 to 247; a parity of None, Odd or Even; and the stop bit is 1.

**Profibus Network Communications**

The Profibus Network Card OPTC3 is used for connecting the 9000X Drive as a slave on a Profibus-DP network. The interface is connected by a 9-pin DSUB connector (female). The baud rates range from 9.6K baud to 12M baud, and the addresses range from 1 to 127.

**LonWorks Network Communications**

The LonWorks Network Card OPTC4 is used for connecting the 9000X Drive on a LonWorks network. This interface uses Standard Network Variable Types (SNVT) as data types. The channel connection is achieved using a FTT-10A Free Topology transceiver via a single twisted transfer cable. The communication speed with LonWorks is 78 kBits/s.

**CanOpen (Slave) Communications**

The CanOpen (Slave) Network Card OPTC6 is used for connecting the 9000X Drive to a host system. According to ISO11898 standard cables to be chosen for CAN bus should have a nominal impedance of 120 ohms, and specific line delay of nominal 5 nS/m. 120 ohms line termination resistors required for installation.

**DeviceNet Network Communications**

The DeviceNet Network Card OPTC7 is used for connecting the 9000X Drive on a DeviceNet Network. It includes a 5.08 mm pluggable connector. Transfer method is via CAN using a two-wire twisted shielded cable with two-wire bus power cable and drain. The baud rates used for communication include 125K baud, 250K baud and 500K baud.

**Johnson Controls Metasys N2 Network Communications**

The OPTC2 fieldbus board provides communication between the 9000X Drive and a Johnson Controls Metasys™ N2 network. With this connection, the drive can be controlled, monitored and programmed from the Metasys system. The N2 fieldbus is available as a factory installed option and as a field installable kit.

**Modbus/TCP Network Communications**

The Modbus/TCP Network Card OPTCI is used for connecting the 9000X Drive to Ethernet networks utilizing Modbus protocol. It includes an RJ-45 pluggable connector. This interface provides a selection of standard and custom register values to communicate drive parameters. The board supports 10 Mbps and 100 Mbps communication speeds. The IP address of the board is configurable over Ethernet using a supplied software tool.

**BACnet Network Communications**

The BACnet Network Card OPTCJ is used for connecting the 9000X Drive to BACnet networks. It includes a 5.08 mm pluggable connector. Data transfer is Master-Slave/Token Passing (MS/TP) RS-485. This interface uses a collection of 30 Binary Value Objects (BVOs) and 35 Analog Value Objects (AVOs) to communicate drive parameters. The card supports 9.6, 19.2 and 38.4 Kbaud communication speeds and supports network addresses 1–127.

**Ethernet/IP Network Communications**

The Ethernet/IP Network Card OPTCK is used for connecting the 9000X Drive to Ethernet/Industrial Protocol networks. It includes an RJ-45 pluggable connector. The interface uses CIP objects to communicate drive parameters (CIP is “Common Industrial Protocol”, the same protocol used by DeviceNet). The board supports 10 Mbps and 100 Mbps communication speeds. The IP address of the board is configurable by Static, BOOTP and DHCP methods.

#### Control Panel Options

#### Factory Options

Description	Factory Installed Option Code	Field Installed NEMA Type 1/IP21 Catalog Number
<b>Local/Remote Keypad SVX9000 Control Panel</b> —This option is standard on all drives and consists of an RS-232 connection, backlit alphanumeric LCD display with nine indicators for the RUN status and two indicators for the control source. The nine pushbuttons on the panel are used for panel programming and monitoring of all SVX9000 parameters. The panel is detachable and isolated from the input line potential. Include LOC/REM key to choose control location.	<b>A</b>	<b>KEYPAD-LOC/REM</b>
<b>Keypad Remote Mounting Kit</b> —This option is used to remote mount the SVX9000 keypad. The footprint is compatible to the SV9000 remote mount kit. Includes 10 ft cable, keypad holder and mounting hardware.	—	<b>OPTRMT-KIT-9000X</b>

#### Miscellaneous Options

Description	Catalog Number
<b>9000XDrive</b> —A PC-based tool for controlling and monitoring of the SVX9000. Features include: loading parameters that can be saved to a file or printed, setting references, starting and stopping the motor, monitoring signals in graphical or text form, and real-time display. To avoid damage to the drive or computer, SVDriveable must be used.	<b>9000XDRIVE</b>
<b>SVDriveable</b> —6 ft (1.8m) RS-232 cable (22 gauge) with a 7-pin connector on each end. Should be used in conjunction with the 9000XDrive option to avoid damage to the SVX9000 or computer. The same cable can be used for downloading specialized applications to the drive.	<b>SVDRIVECABLE</b>
<b>External Dynamic Braking Resistors</b> —Used with the dynamic braking chopper circuit to absorb motor regenerative energy for stopping the load and to dissipate the energy flowing back into the drive. Resistors are separated into standard duty and heavy-duty. Standard duty is defined as 20% duty or less with 100% braking torque, while heavy-duty is defined as 50% duty or less with 150% braking torque.	①

#### Open Drive Options

#### Brake Chopper Options

The brake chopper circuit option is used for applications that require dynamic braking. Dynamic braking resistors are not included with drive

purchase. Consult the factory for dynamic braking resistors which are supplied separately. Resistors are not UL Listed.

For brake chopper circuit selection and adder—NEMA Type 1/IP21, NEMA Type 12/IP54, Chassis, consult the factory. Delivery code is FP.

#### Conformal (Varnished) Coating ②

Chassis Frame	Delivery Code
FR4	FP
FR5	FP
FR6	FP
FR7	FP
FR8	FP
FR9	FP
FR10	FP
FR11	FP
FR12	FP
FR13	FP
FR14	FP

#### Conformal Coated Board Kits ③

Field Installed Catalog Number	Factory Installed Option Designator
<b>OPT_V</b> ④	⑤

#### Notes

- ① Consult factory.
- ② See Product Selection on **Pages V6-T36-19 to V6-T36-22**, 208–240V, 380–500V, 525–690V. Consult the factory for adder.
- ③ See option catalog numbers on **Page V6-T36-24**.
- ④ Replace “\_” with the correct catalog number from **Page V6-T36-24**. Example: OPTC2V.
- ⑤ Construct catalog numbers for factory installed per Catalog Number Selection on **Page V6-T36-18**.

## Replacement Parts

## SVX9000 Drives Spare Units

## 208–690V, Frames 4–12

## Description

## Catalog Number

Control unit—Includes the control board, blue base housing, installed SVX9000 software program and blue flip cover. Does not include any OPT boards or keypad. See [Page V6-T36-24](#) for standard and option boards and keypad.

CSBS0000000000

## SVX9000 Drives Replacement Parts

## 208–240V, Frames FR4–FR8

Frame	4		5		5 <sup>①</sup>		5		7-1/2		6		7		8		Delivery Code	Catalog Number	
hp (I <sub>H</sub> ):	3/4	1	1-1/2	2	3	5	5	7-1/2	10	15	20	25	30	40	50	60			
<b>Control Board</b>																			
1	1	1	1	1	1	1	1	1	1	1	1	1	1	1	1	1	1	W	VB00252
<b>Power Boards</b>																			
1																		FB	VB00308-0004-2
	1																	FB	VB00308-0007-2
		1																FB	VB00308-0008-2
			1															FB	VB00310-0011-2
				1														FB	VB00310-0012-2
					1													FB	VB00313-0017-2
						1												FB	VB00313-0025-2
							1											FB	VB00313-0031-2
								1										FB	VB00316-0048-2
									1									FB	VB00316-0061-2
										1								FB	VB00319-0075-2
											1							FB	VB00319-0088-2
												1						FB	VB00319-0114-2
													1					FB	VB00322-0140-2
														1				FB	VB00322-0170-2
															1			FB	VB00322-0205-2
<b>Electrolytic Capacitors</b>																			
2	2	2																W	PP01000
			2	2														W	PP01001
					2	2												W	PP01002
							2											W	PP01003
								2										W	PP01004
									2	2								W	PP01005
											2	2	2	4	4			W	PP01099
																4		W	PP01099
<b>Cooling Fans</b>																			
1	1	1	1	1														W	PP01060
					1	1	1											W	PP01061
								1	1									W	PP01062
										1	1	1						W	PP01063
														1	1	1		FC	PP01123 <sup>②</sup>
1	1	1	1	1														W	PP01086
					1	1	1	1	1									FC	PP01088
										1	1	1						W	PP01049
														1	2	2		FC	CP01180
														1	1	1		FC	PP08037

## Notes

① I<sub>L</sub> only; has no corresponding I<sub>H</sub> rated hp rating.

② PP00061 capacitor not included in main fan; please order separately.

# 36.3

## Adjustable Frequency Drives

### SVX9000 Drives

36

#### 208–240V, Frames FR4–FR8, continued

Frame	4				5				6				7				8				Delivery Code	Catalog Number
hp (I <sub>H</sub> ):	3/4	1	1-1/2	2	3	5 <sup>Ⓢ</sup>	5	7-1/2	10	15	20	25	30	40	50	60						
<b>IGBT Modules</b>																						
	1	1																		W	CP01304	
			1																	W	CP01305	
				1	1	1														W	CP01306	
							1													W	CP01307	
								1												W	CP01308	
									1											W	PP01022	
										1										W	PP01023	
											1									W	PP01024	
												1								W	PP01025	
													1							W	PP01029	
														1						W	PP01026	
															1	1				W	PP01027	
<b>Choppers/Rectifiers</b>																						
										1										W	CP01367	
											1									W	CP01368	
<b>Diode/Thyristor Modules</b>																						
												3	3	3						W	PP01035	
															3	3	3			W	CP01268	
<b>Rectifying Boards</b>																						
												1	1	1						W	VB00242	
																1	1	1		W	VB00227	

#### 380–500V, Frames FR4–FR9

Frame	4				5				6				7				8				9				Delivery Code	Catalog Number
hp (I <sub>H</sub> ):	1	1-1/2	2	3	5	7-1/2 <sup>Ⓢ</sup>	7-1/2	10	15	20	25	30	40	50	60	75	100	125	150	200						
<b>Control Board</b>																										
	1	1	1	1	1	1	1	1	1	1	1	1	1	1	1	1	1	1	1	1	1	W	VB00252			
<b>Power Boards</b>																										
	1																					FB	VB00208-0003-5			
		1																				FB	VB00208-0004-5			
			1																			FB	VB00208-0005-5			
				1																		FB	VB00208-0007-5			
					1																	FB	VB00208-0009-5			
						1																FB	VB00210-0012-5			
							1															FB	VB00213-0016-5			
								1														FB	VB00213-0022-5			
									1													FB	VB00213-0031-5			
										1												FB	VB00216-0038-5			
											1											FB	VB00216-0045-5			
												1										FB	VB00216-0061-5			
													1									FB	VB00219-0072-5			
														1								FB	VB00219-0087-5			
															1							FB	VB00219-0105-5			
																1						FB	VB00236-0140-5			
																	1					FB	VB00236-0168-5			
																		1				FB	VB00236-0205-5			

**Note**  
<sup>Ⓢ</sup> I<sub>L</sub> only; has no corresponding I<sub>H</sub> rated hp rating.

## 380–500V, Frames FR4–FR9, continued

Frame	4		5			6				7			8		9			Delivery Code	Catalog Number			
hp (I <sub>H</sub> ):	1	1-1/2	2	3	5	7-1/2 <sup>①</sup>	7-1/2	10	15	20	25	30	40	50	60	75	100	125	150	200		
<b>Electrolytic Capacitors</b>																						
	2	2	2																		W	PP01000
				2	2																W	PP01001
						2	2														W	PP01002
								2	2												W	PP01003
										2	2	2									W	PP01004
													2	2	2	4	4	4	8	8	W	PP01005
<b>Cooling Fans</b>																						
	1	1	1	1	1	1															W	PP01060
							1	1	1												W	PP01061
										1	1	1									W	PP01062
													1	1	1						W	PP01063
																1	1	1			FC	PP01123 <sup>②</sup>
																			1	1	FC	PP01080 <sup>③</sup>
	1	1	1	1	1	1															W	PP01086
							1	1	1												FC	PP01088
										1	1	1	1	1	1						W	PP01049
																1	1	1			FC	CP01180
																			1 <sup>④</sup>	2	W	PP01068
																			1	1	FC	PP09051
<b>IGBT Modules</b>																						
	1	1	1																		W	CP01304
				1	1																W	CP01305
						1	1														W	CP01306
								1													W	CP01307
									1												W	CP01308
										1											W	PP01020
											1										W	PP01022
												1									W	PP01023
													1								W	PP01024
														1							W	PP01025
															1						W	PP01029
																1					W	PP01026
																	1	1			W	PP01027
<b>Chopper/Rectifiers</b>																						
									1	1											W	CP01367
											1										W	CP01368
<b>Diode/Thyristor Modules</b>																						
												3	3	3							W	PP01035
															3	3	3				W	CP01268
																		3	3	W	PP01037	

**Notes**

- ① I<sub>L</sub> only; has no corresponding I<sub>H</sub> rated hp rating.  
 ② PP00061 capacitor not included in main fan; please order separately.  
 ③ PP00011 capacitor not included in main fan; please order separately.  
 ④ For FR9 NEMA Type 12/IP54 you need two PP01068 internal fans.

# 36.3

## Adjustable Frequency Drives

### SVX9000 Drives

36

#### 380–500V, Frames FR4–FR9, continued

Frame	4		5			6		7		8		9			Delivery Code	Catalog Number							
hp (I <sub>H</sub> ):	1	1-1/2	2	3	5	7-1/2 <sup>①</sup>	7-1/2	10	15	20	25	30	40	50	60	75	100	125	150	200			
<b>Rectifying Boards</b>																							
													1	1	1							W	VB00242
																						W	VB00227
																						W	VB00459
<b>Rectifying Module Sub-Assembly</b>																							
																				1	1	W	FR09810
<b>Power Module Sub-Assemblies</b>																							
																					1	W	FR09-150-4-ANS <sup>②</sup>
																					1	W	FR09-200-4-ANS <sup>②</sup>

#### 380–500V, Frames FR10–FR12

Frame	10		11			12			Delivery Code	Catalog Number	
hp (I <sub>H</sub> ):	250	300	350	400	500	550	600	650	700		
<b>Control Board</b>											
	1	1	1	1	1	1	1	1	1	W	VB00561 <sup>③</sup>
<b>Shunt Boards</b>											
	6									FC	VB00537
		6								FC	VB00497
			6				12	12	12	FC	VB00498
				9						FC	VB00538
					9					FC	VB00513
						9				FC	VB00514
<b>Driver Boards</b>											
				3	3	3				FC	VB00489
	1	1	1				2	2	2	FC	VB00487
<b>Driver Adapter Board</b>											
	1	1	1				2	2	2	FC	VB00330
<b>ASIC Board</b>											
	1	1	1	1	1	1	2	2	2	FC	VB00451
<b>Feedback Interface Board</b>											
							2	2	2	FC	VB00448
<b>Star Coupler Board</b>											
							1	1	1	FC	VB00336
<b>Power Modules</b>											
	1	1	1	2	2	2	2	2	2	FC	FR10820 <sup>④</sup>
	2	2	2							FC	FR10828
	1									FC	FR10-250-4-ANS <sup>②</sup>
		1								FC	FR10-300-4-ANS <sup>②</sup>
			1				2	2	2	FC	FR10-350-4-ANS <sup>②</sup>
				3						FC	FR11-400-4-ANS <sup>②</sup>
					3					FC	FR11-500-4-ANS <sup>②</sup>
						3				FC	FR11-550-4-ANS <sup>②</sup>

**Notes**

- ① I<sub>L</sub> only; has no corresponding I<sub>H</sub> rated hp rating.
- ② See **Page V6-T36-18** for details.
- ③ SPX9000 drives only (FR10 and larger).
- ④ Rectifying board not included.

## 380–500V, Frames FR10–FR12, continued

Frame	10			11			12			Delivery Code	Catalog Number
hp (I <sub>H</sub> ):	250	300	350	400	500	550	600	650	700		
<b>Electrolytic Capacitors</b>											
2	2	2	2	3	3	3	4	4	4	FC	PP00060
12	12	12	12	18	18	18	24	24	24	FC	PP01005
<b>Fuses</b>											
1	1	1	1	1	1	1	2	2	2	FC	PP01094
2	2	2	2	2	2	2	4	4	4	FC	PP01095
<b>Cooling Fans and Isolation Transformers</b>											
2	2	2	3	3	3	3	4	4	4	FC	VB00299
2	2	2	3	3	3	3	4	4	4	FC	PP01080 <sup>①</sup>
2	2	2					4	4	4	FC	PP01068
1	1	1	1	1	1	1	2	2	2	FC	PP01096
1	1	1					2	2	2	FC	FR10844
1	1	1	3	3	3	3	2	2	2	FC	FR10845
1	1	1					2	2	2	FC	FR10846
1	1	1	3	3	3	3	2	2	2	FC	FR10847
<b>Rectifying Board</b>											
1	1	1	2	2	2	2	2	2	2	FC	VB00459

## 525–690V, Frames FR6–FR9

Frame	6			7						8		9					Delivery Code	Catalog Number		
hp (I <sub>H</sub> ):	2	3	5 <sup>②</sup>	5	7-1/2	10	15	20	25	30	40	50	60	75	100	125			150	200 <sup>②</sup>
<b>Control Board</b>																				
1	1	1	1	1	1	1	1	1	1	1	1					1	1	1	W	VB00252
<b>Driver Boards</b>																				
1																			FB	VB00404-0004-6
	1																		FB	VB00404-0005-6
		1																	FB	VB00404-0007-6
			1																FB	VB00404-0010-6
				1															FB	VB00404-0013-6
					1														FB	VB00404-0018-6
						1													FB	VB00404-0022-6
							1												FB	VB00404-0027-6
								1											FB	VB00404-0034-6
<b>Power Boards</b>																				
										1									FB	VB00419-0041-6
											1								FB	VB00419-0052-6
												1							FB	VB00422-0062-6
													1						FB	VB00422-0080-6
														1					FB	VB00422-0100-6
<b>Power Modules</b>																				
															1				FC	FR09-100-5-ANS <sup>③</sup>
																1			FC	FR09-125-5-ANS <sup>③</sup>
																	1		FC	FR09-150-5-ANS <sup>③</sup>
																		1	FC	FR09-175-5-ANS <sup>③</sup>

**Notes**

① PP00060 capacitor not included in main fan; please order separately.

② I<sub>L</sub> only; has no corresponding I<sub>H</sub> rated hp rating.

③ See Page V6-T36-18 for details.

# 36.3

## Adjustable Frequency Drives

### SVX9000 Drives

#### 525–690V, Frames FR6–FR9, continued

Frame	6						7				8		9				Delivery Code	Catalog Number		
hp (I <sub>H</sub> ):	2	3	5 <sup>①</sup>	5	7-1/2	10	15	20	25	30	40	50	60	75	100	125			150	200 <sup>①</sup>
<b>Electrolytic Capacitors</b>																				
	2	2	2	2	2	2	2	2	2										FC	PP01093
										2	2	4	4		8	8	8	8	FC	PP01041
														4					FC	PP01040
<b>Fuses</b>																				
												1	1	1	1	1	1	1	W	PP01094
												2	2	2	2	2	2	2	W	PP01095
<b>Cooling Fans</b>																				
	1	1	1	1	1														W	PP01061
						1	1	1	1										W	PP01062
										1	1								W	PP01063
												1	1	1					FC	PP01123
	1	1	1	1	1	1	1	1	1	1	1								W	PP01049
												1	1	1					FC	CP01180
															1	1	1	1 <sup>②</sup>	W	PP01068
															1	1	1	1	FC	PP01080
<b>Fan Power Supply</b>																				
																1	1	1	FC	VB00299
<b>IGBT Modules</b>																				
	3	3	3	3	3	3	3	3	3										FC	PP01091
										1	1								FC	PP01089
												1	1	1					FC	PP01127
<b>IGBT/Diode (Brake)</b>																				
	1	1	1	1	1	1	1	1	1	1	1	2	2	2	2	2	2	2	FC	PP01040
<b>Diode Module</b>																				
	1	1	1	1	1	1	1	1	1										FC	PP01092
<b>Diode/Thyristor Modules</b>																				
										3	3								FC	PP01071
															3	3	3	3	FC	PP01072
<b>Rectifying Boards</b>																				
										1	1								FC	VB00442
															1	1	1	1	FC	VB00460
<b>Rectifying Module Sub-Assemblies</b>																				
																1	1	1	W	FR09810
																1	1	1	FC	FR09811

**Notes**

- ① I<sub>L</sub> only; has no corresponding I<sub>H</sub> rated hp rating.
- ② For NEMA Type 12/IP54, two PP01068 internal fans are needed.



## 525–690V, Frames FR10–FR12

Frame hp (I <sub>H</sub> ):	10		11			12			Delivery Code	Catalog Number	
	200	250	300	400	450	500	550	600			700
<b>Component Boards</b>											
	1	1	1	1	1	1	1	1	1	W	VB00561 <sup>①</sup>
	1	1	1	1	1	1	2	2	2	FC	VB00451
	6									FC	VB00545
		6								FC	VB00510
			6				12	12	12	FC	VB00511
	1	1	1				2	2	2	FC	VB00330
	1	1	1				2	2	2	FC	VB00487
				3	3	3				FC	VB00489
				9						FC	VB00546
					9					FC	VB00547
						9				FC	VB00512
							2	2	2	FC	VB00448
							1	1	1	FC	VB00336
<b>Power Modules</b>											
	1	1	1	2	2	2	2	2	2	FC	FR10821 <sup>②</sup>
	2	2	2							FC	FR10829
	1									FC	FR10-200-5-ANS <sup>③</sup>
		1								FC	FR10-250-5-ANS <sup>③</sup>
			1				2	2	2	FC	FR10-300-5-ANS <sup>③</sup>
				3						FC	FR11-400-5-ANS <sup>③</sup>
					3					FC	FR11-450-5-ANS <sup>③</sup>
						3				FC	FR11-500-5-ANS <sup>③</sup>
<b>Electrolytic Capacitors</b>											
	2	2	2	3	3	3	4	4	4	FC	PP00060
	12	12	12	18	18	18	24	24	24	FC	PP01099
<b>Fuses</b>											
	1	1	1	1	1	1	2	2	2	FC	PP01094
	2	2	2	2	2	2	4	4	4	FC	PP01095
<b>Cooling Fans and Isolation Transformers</b>											
	2	2	2	3	3	3	4	4	4	FC	VB00299
	2	2	2	3	3	3	4	4	4	FC	PP01080 <sup>④</sup>
	2	2	2				4	4	4	FC	PP01068
	1	1	1	1	1	1	2	2	2	FC	PP01096
	1	1	1				2	2	2	FC	FR10844
	1	1	1	3	3	3	2	2	2	FC	FR10845
	1	1	1				2	2	2	FC	FR10846
	1	1	1	3	3	3	2	2	2	FC	FR10847
<b>Fan Power Supply</b>											
							1	1	1	FC	VB00299
<b>Rectifying Boards</b>											
	1	1	1	2	2	2	2	2	2	FC	VB00460

**Notes**

- ① SPX9000 drives only (FR10 and larger).  
 ② Rectifying board not included.  
 ③ See **Page V6-T36-18** for details.  
 ④ PP00060 capacitor not included in main fan; please order separately.

## Technical Data and Specifications

### SVX9000 Drives

Description	Specification
<b>Input Ratings</b>	
Input voltage ( $V_{in}$ )	+10%/–15%
Input frequency ( $f_{in}$ )	50/60 Hz (variation up to 45–66 Hz)
Connection to power	Once per minute or less (typical operation)
High withstand rating	100 kAIC
<b>Output Ratings</b>	
Output voltage	0 to $V_{in}$
Continuous output current	$I_H$ rated 100% at 122°F (50°C), FR9 and below $I_L$ rated 100% at 104°F (40°C), FR9 and below $I_H/I_L$ 100% at 104°F (40°C), FR10 and above
Overload current ( $I_H/I_L$ )	150% $I_H$ , 110% $I_L$ for 1 min.
Output frequency	0 to 320 Hz
Frequency resolution	0.01 Hz
Initial output current ( $I_H$ )	250% for 2 seconds
<b>Control Characteristics</b>	
Control method	Frequency control (V/f) Open loop: Sensorless vector control Closed loop: SPX9000 drives only
Switching frequency Frame 4–6 Frame 7–12	Adjustable with parameter 2.6.9 1–16 kHz; default 10 kHz 1–10 kHz; default 3.6 kHz
Frequency reference	Analog input: Resolution 0.1% (10-bit), accuracy $\pm 1\%$ V/Hz Panel reference: Resolution 0.01 Hz
Field weakening point	30–320 Hz
Acceleration time	0–3000 sec.
Deceleration time	0–3000 sec.
Braking torque	DC brake: 30% $\times T_n$ (without brake option)
<b>Ambient Conditions</b>	
Ambient operating temperature	14°F (–10°C), no frost to 122°F (50°C) $I_H$ (FR4–FR9) 14°F (–10°C), no frost to 104°F (40°C) $I_H$ (FR10 and up) 14°F (–10°C), no frost to 104°F (40°C) $I_L$ (all frames)
Storage temperature	–40° to 158°F (–40° to 70°C)
Relative humidity	0 to 95% RH, noncondensing, non-corrosive, no dripping water
Air quality	Chemical vapors: IEC 721-3-3, unit in operation, class 3C2; Mechanical particles: IEC 721-3-3, unit in operation, class 3S2
Altitude	100% load capacity (no derating) up to 3280 ft (1000m); 1% derating for each 328 ft (100m) above 3280 ft (1000m); max. 9842 ft (3000m)
Vibration	EN 50178, EN 60068-2-6; 5 to 50 Hz, displacement amplitude 1 mm (peak) at 3 to 15.8 Hz, max. acceleration amplitude 1G at 15.8 to 150 Hz
Shock	EN 50178, EN 60068-2-27 UPS Drop test (for applicable UPS weights) Storage and shipping: max. 15G, 11 ms (in package)
Enclosure class	NEMA 1/IP21 or NEMA 12/IP54, open chassis/IP20

Description	Specification
<b>Control Connections</b>	
Analog input voltage	0 to 10V, $R = 200$ kohms (–10 to 10V joystick control) resolution 0.1%; accuracy $\pm 1\%$
Analog input current	0(4) to 20 mA; $R_T = 250$ ohms differential
Digital inputs (6)	Positive or negative logic; 18 to 30 Vdc
Auxiliary voltage	+24V $\pm 15\%$ , max. 250 mA
Output reference voltage	+10V $\pm 3\%$ , max. load 10 mA
Analog output	0(4) to 20 mA; $R_L$ max. 500 ohms; resolution 10 bit; accuracy $\pm 2\%$
Digital outputs	Open collector output, 50 mA/48V
Relay outputs	Two programmable Form C relay outputs switching capacity: 24 Vdc/8A, 250 Vac/8A, 125 Vdc/0.4A
<b>Protections</b>	
Overcurrent protection	Trip limit 4.0 $\times I_H$ instantaneously
Overvoltage protection	Yes
Undervoltage protection	Yes
Earth fault protection	In case of earth fault in motor or motor cable, only the frequency converter is protected
Input phase supervision	Trips if any of the input phases are missing
Motor phase supervision	Trips if any of the output phases are missing
Overtemperature protection	Yes
Motor overload protection	Yes
Motor stall protection	Yes
Motor underload protection	Yes
Short circuit protection	Yes (+24V and +10V reference voltages)

### Standard I/O Specifications

Description	Specification
Six–digital input programmable	24V: "0" $\leq 10V$ , "1" $\geq 18V$ , $R_i > 5$ kohms
Two–analog input configurable w/jumpers	Voltage: 0– $\pm 10V$ , $R_i > 200$ kohms Current: 0 (4)–20 mA, $R_i = 250$ ohms
Two–digital output programmable	Form C relays 250 Vac 30 Vdc 2 amp resistive
One–analog output programmable configurable w/jumper	0–20 mA, $R_L$ max. 500 ohms 10 bits $\pm 2\%$
One digital output programmable	Open collector 48 Vdc 50 mA

**Dimensions**

Approximate Dimensions in Inches (mm)

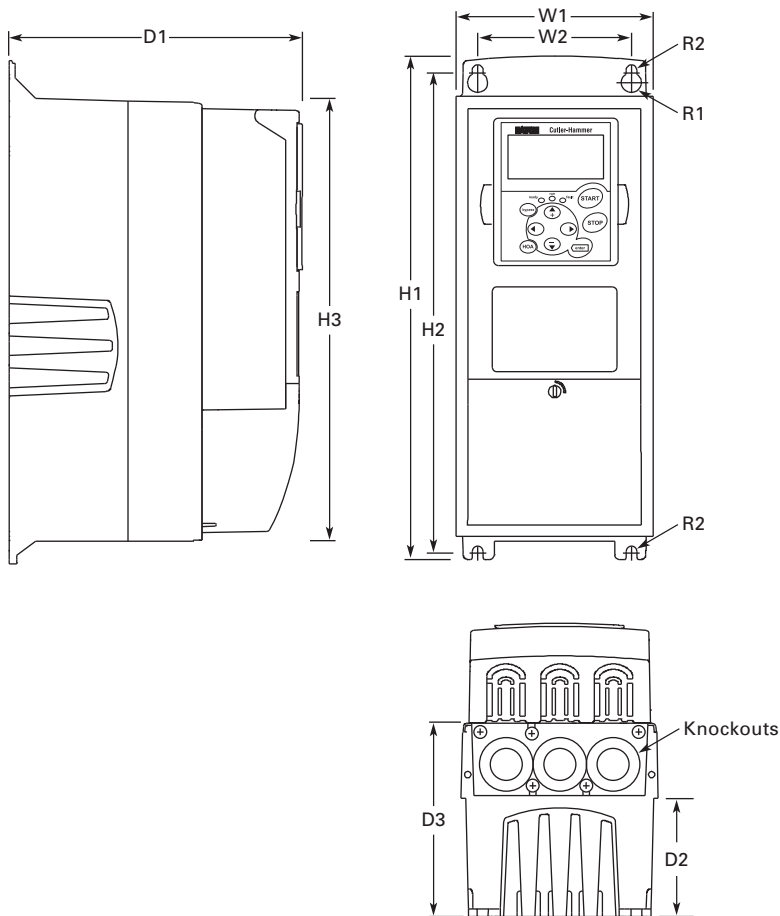
**9000X Open Drives****NEMA Type 1/IP21 and NEMA Type 12/IP54, FR4, FR5 and FR6**

Voltage	hp (I <sub>H</sub> )	H1	H2	H3	D1	D2	D3	W1	W2	R1 Dia.	R2 Dia.	Weight Lbs (kg)	Knockouts at Inches (mm) N1 (O.D.)
<b>FR4</b>													
230V	3/4–3	12.9	12.3	11.5	7.5	3.0	4.9	5.0	3.9	0.5 (13)	0.3 (7)	11.0 (5)	3 @ 1.1 (28)
480V	1–5	(327)	(313)	(292)	(190)	(77)	(126)	(128)	(100)				
<b>FR5</b>													
230V	5–7-1/2	16.5	16.0	15.3	8.4	3.9	5.8	5.6	3.9	0.5 (13)	0.3 (7)	17.9 (8)	2 @ 1.5 (37)
480V	7-1/2–15	(419)	(406)	(389)	(214)	(100)	(148)	(143)	(100)				1 @ 1.1 (28)
<b>FR6</b>													
230V	10–15	22.0	21.3	20.4	9.3	4.2	6.5	7.6	5.8	0.6 (15.5)	0.4 (9)	40.8 (19)	3 @ 1.5 (37)
480V	20–30	(558)	(541)	(519)	(237)	(105)	(165)	(195)	(148)				
575V	2–25												

# 36.3

## Adjustable Frequency Drives

### SVX9000 Drives

Approximate Dimensions in Inches (mm)

#### NEMA Type 1/IP21 and NEMA Type 12/IP54 with Flange Kit, FR4, FR5 and FR6

36

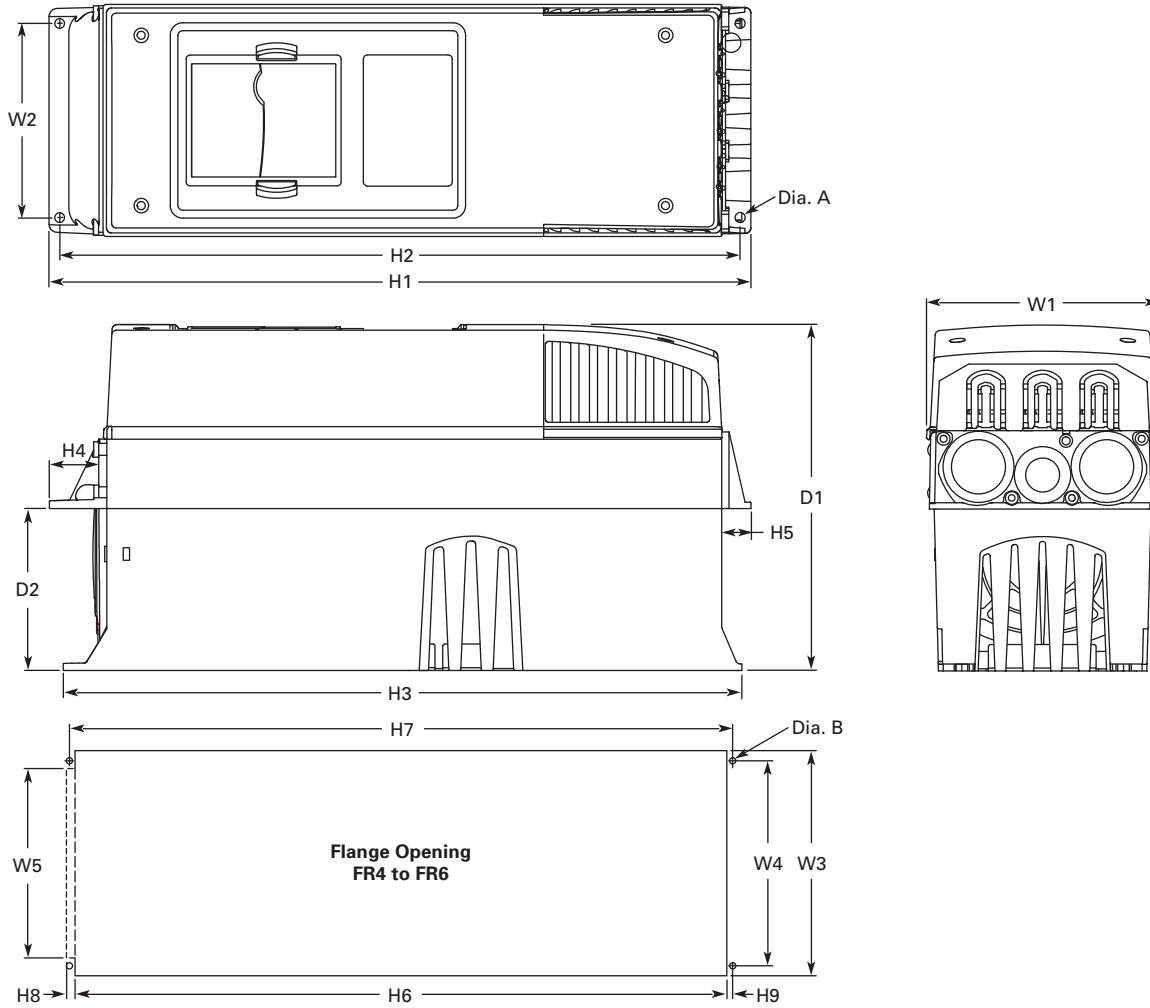

#### FR4, FR5 and FR6 with Flange Kit

W1	W2	H1	H2	H3	H4	H5	D1	D2	Dia. A
<b>FR4</b>									
5.0 (128)	4.5 (113)	13.3 (337)	12.8 (325)	12.9 (327)	1.2 (30)	0.9 (22)	7.5 (190)	3.0 (77)	0.3 (7)
<b>FR5</b>									
5.6 (143)	4.7 (120)	17.0 (434)	16.5 (420)	16.5 (419)	1.4 (36)	0.7 (18)	8.4 (214)	3.9 (100)	0.3 (7)
<b>FR6</b>									
7.7 (195)	6.7 (170)	22.0 (560)	21.6 (549)	22.0 (558)	1.2 (30)	0.8 (20)	9.3 (237)	4.2 (106)	0.3 (7)

#### Flange Opening, FR4 to FR6

W3	W4	W5	H6	H7	H8	H9	Dia. B
<b>FR4</b>							
4.8 (123)	4.5 (113)	—	12.4 (315)	12.8 (325)	—	0.2 (5)	0.3 (7)
<b>FR5</b>							
5.3 (135)	4.7 (120)	—	16.2 (410)	16.5 (420)	—	0.2 (5)	0.3 (7)
<b>FR6</b>							
7.3 (185)	6.7 (170)	6.2 (157)	21.2 (539)	21.6 (549)	0.3 (7)	0.2 (5)	0.3 (7)

Approximate Dimensions in Inches (mm)

NEMA Type 1/IP21 and NEMA Type 12/IP54, FR7

36

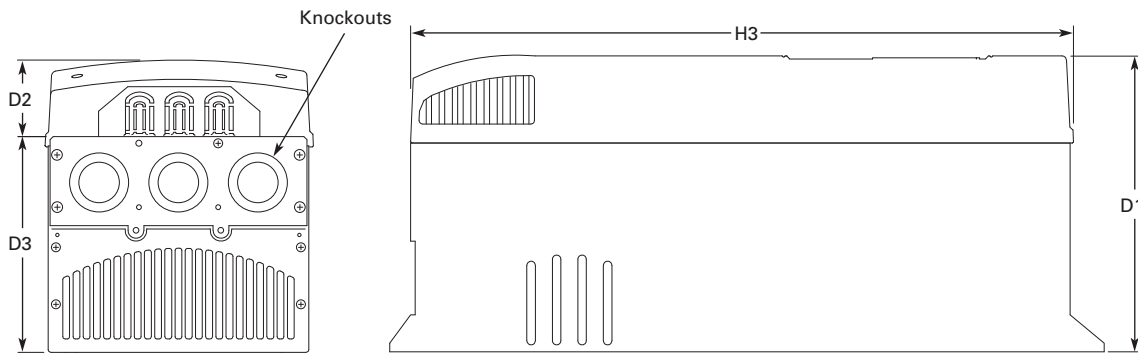
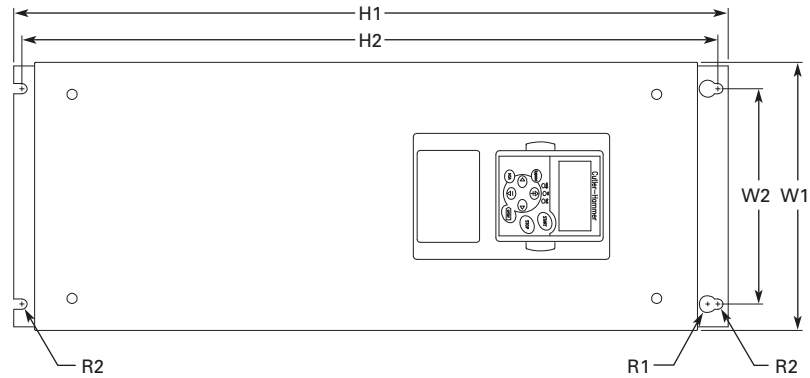

Voltage	hp (I <sub>H</sub> )	H1	H2	H3	D1	D2	D3	W1	W2	R1 Dia.	R2 Dia.	Weight Lbs (kg)	Knockouts at Inches (mm) N1 (O.D.)
230V	20–30	24.8 (630)	24.2 (614)	23.2 (590)	10.1 (257)	3.0 (77)	7.3 (184)	9.3 (237)	7.5 (190)	0.7 (18)	0.4 (9)	77.2 (35)	3 at 1.5 (37)
480V	40–60												
575V	30–40												

# 36.3

## Adjustable Frequency Drives

### SVX9000 Drives

Approximate Dimensions in Inches (mm)

NEMA Type 1/IP21 and NEMA Type 12/IP54, FR8

36

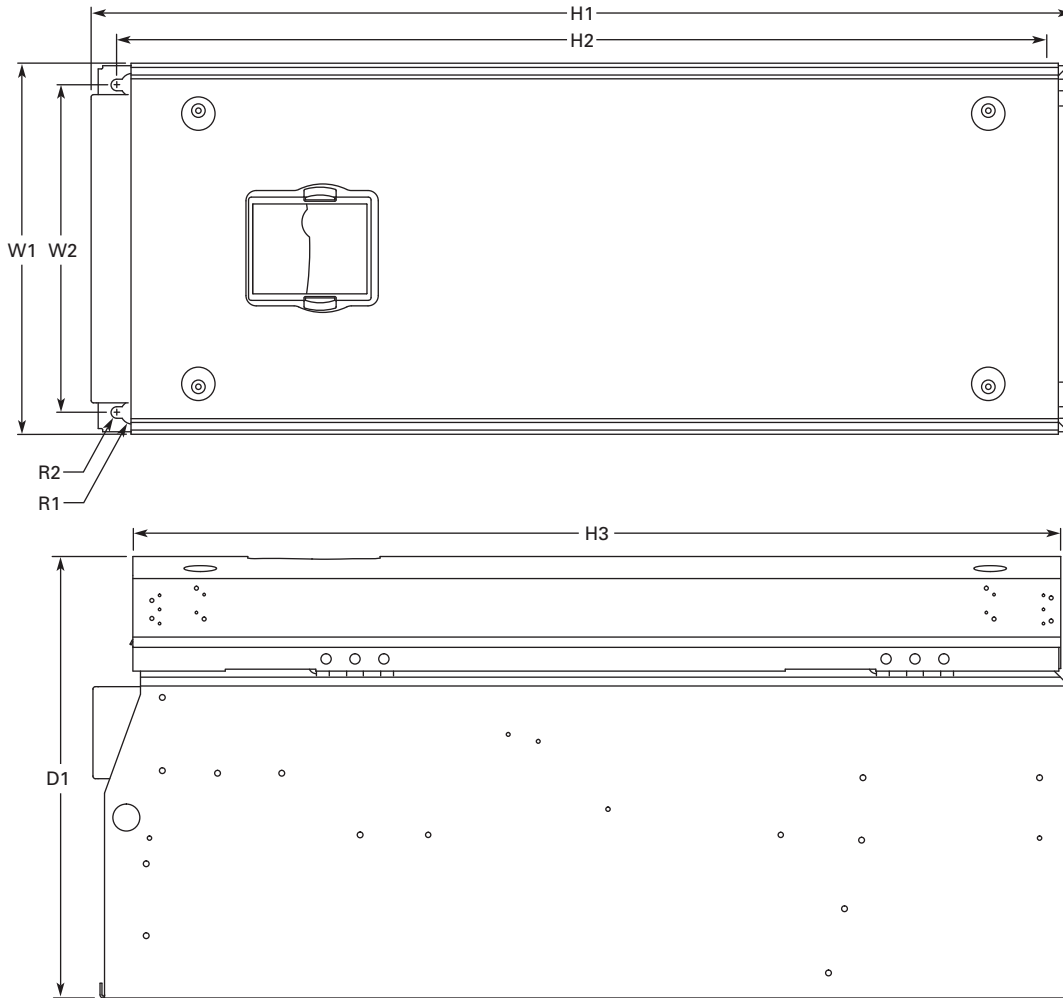

Voltage	hp (I <sub>H</sub> )	D1	H1	H2	H3	W1	W2	R1 Dia.	R2 Dia.	Weight Lbs (kg)
230V	40–60	13.5 (344)	30.1 (764)	28.8 (732)	28.4 (721)	11.5 (291)	10 (255)	0.7 (18)	0.4 (9)	127 (58)
480V	75–125									
575V	50–75									

Approximate Dimensions in Inches (mm)

**NEMA Type 1/IP21 and NEMA Type 12/IP54, with Flange Kit, FR7 and FR8**

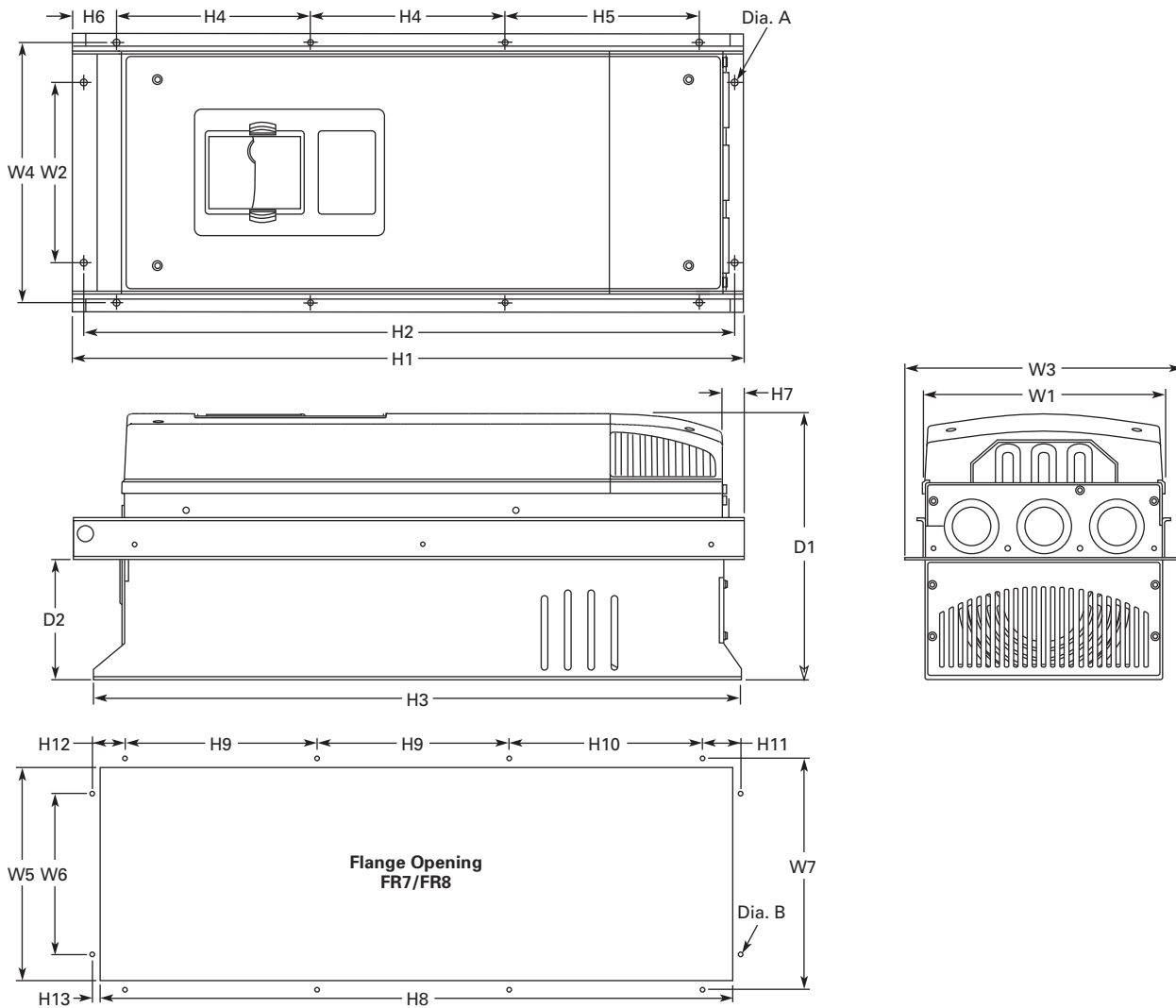

W1	W2	W3	W4	H1	H2	H3	H4	H5	H6	H7	D1	D2	Dia. A
<b>FR7</b>													
9.3 (237)	6.8 (175)	10.6 (270)	10.0 (253)	24.9 (652)	24.8 (632)	24.8 (630)	7.4 (189)	7.4 (189)	0.9 (23)	0.8 (20)	10.1 (257)	4.6 (117)	0.3 (6)
<b>FR8</b>													
11.2 (285)	—	14.0 (355)	13.0 (330)	32.8 (832)	—	29.3 (745)	10.2 (258)	10.4 (265)	1.7 (43)	2.2 (57)	13.5 (344)	4.3 (110)	0.4 (9)

**Flange Opening, FR7 and FR8**

W5	W6	W7	H8	H9	H10	H11	H12	H13	Dia. B
<b>FR7</b>									
9.2 (233)	6.9 (175)	10.0 (253)	24.4 (619)	7.4 (189)	7.4 (189)	1.4 (35)	1.3 (32)	1.0 (25)	0.3 (6)
<b>FR8</b>									
11.9 (301)	—	13.0 (330)	31.9 (810)	10.2 (258)	10.4 (265)	—	—	1.3 (33)	0.4 (9)

# 36.3

## Adjustable Frequency Drives

SVX9000 Drives

Approximate Dimensions in Inches (mm)

**NEMA Type 1/IP21 and NEMA Type 12/IP54, FR9**

36

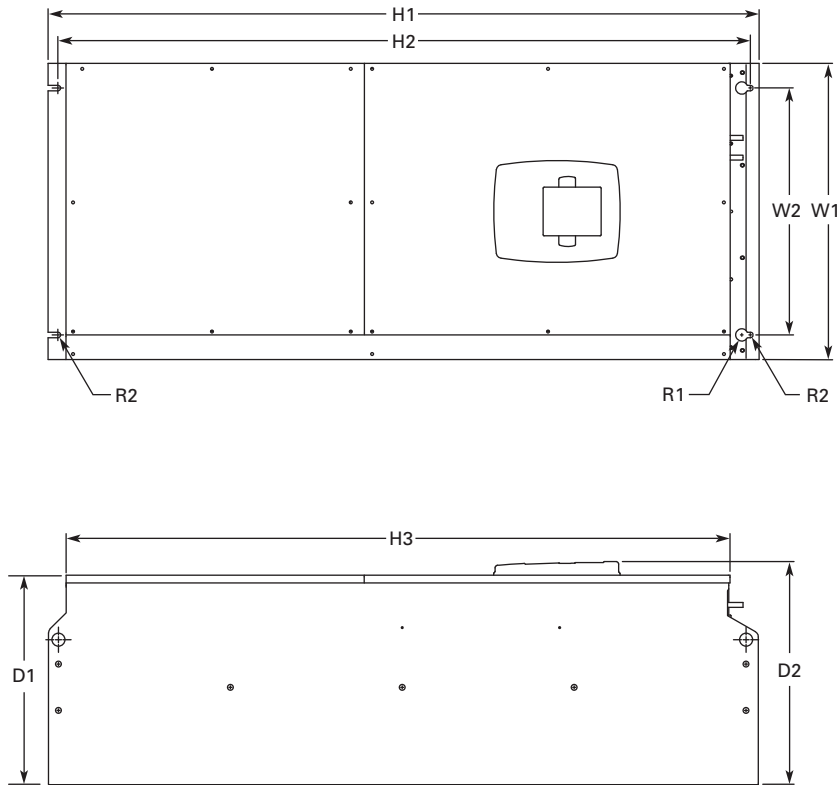

Voltage	hp (I <sub>H</sub> )	H1	H2	H3	D1	D2	W1	W2	R1 Dia.	R2 Dia.	Weight Lbs (kg)
230V	75–100	45.3 (1150)	44.1 (1120)	42.4 (1076)	13.4 (340)	14.3 (362)	18.9 (480)	15.7 (400)	0.8 (20)	0.4 (9)	321.9 (146)
480V	150–200										
575V	100–175										



Approximate Dimensions in Inches (mm)

**NEMA Type 1/IP21 and NEMA Type 12/IP54 FR9, continued**

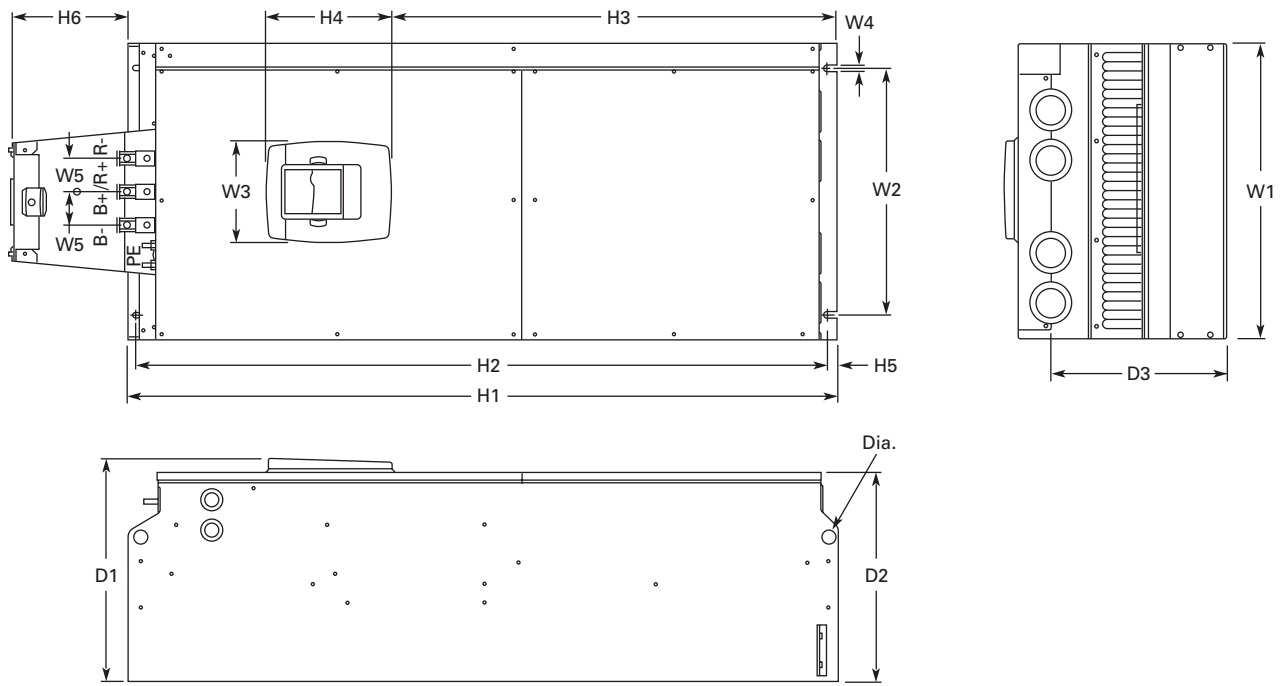

W1	W2	W3	W4	W5	H1	H2	H3	H4	H5	H6 ①	D1	D2	D3	Dia.
18.9 (480)	15.7 (400)	6.5 (165)	0.4 (9)	2.1 (54)	45.3 (1150)	44.1 (1120)	28.3 (721)	8.0 (205)	0.6 (16)	7.4 (188)	14.2 (361.5)	13.4 (340)	11.2 (285)	0.8 (21)

**Note**

① Brake resistor terminal box (H6) included when brake chopper ordered.

# 36.3 Adjustable Frequency Drives

SVX9000 Drives

Approximate Dimensions in Inches (mm)

NEMA Type 1/IP21 and NEMA Type 12/IP54, FR9 with Flange Kit

36

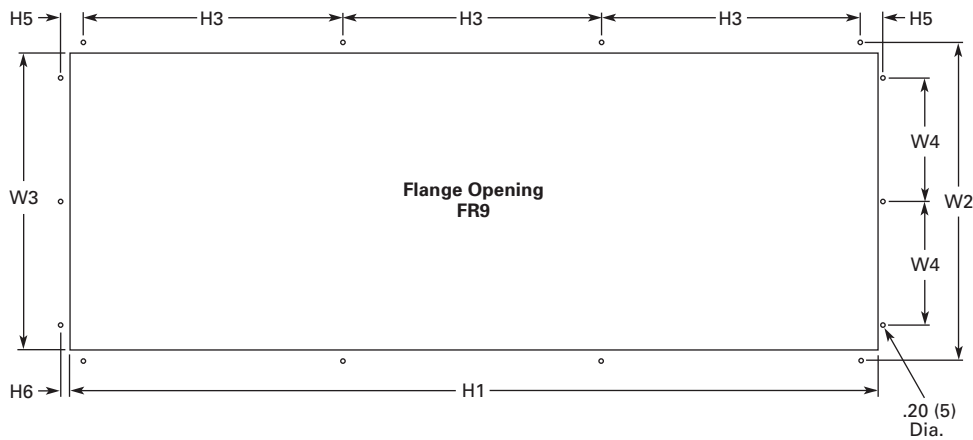
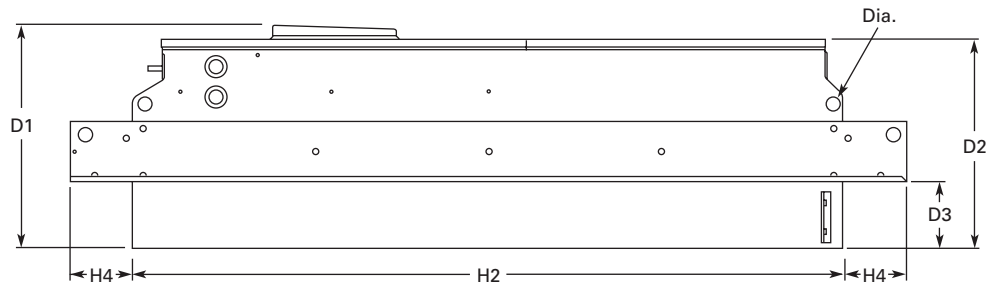
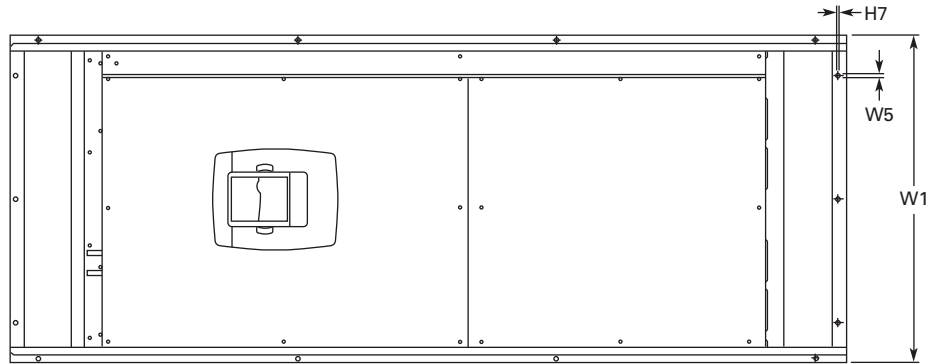

W1	W2	W3	W4	W5	H1	H2	H3	H4	H5	H6	H7	D1	D2	D3	Dia.
20.9 (530)	20.0 (510)	19.1 (485)	7.9 (200)	0.2 (5.5)	51.7 (1312)	45.3 (1150)	16.5 (420)	3.9 (100)	1.4 (35)	0.4 (9)	0.1 (2)	24.9 (362)	13.4 (340)	4.3 (109)	0.8 (21)

Approximate Dimensions in Inches (mm)

**NEMA Type 1/IP21 and NEMA Type 12/IP54, FR10 Freestanding**

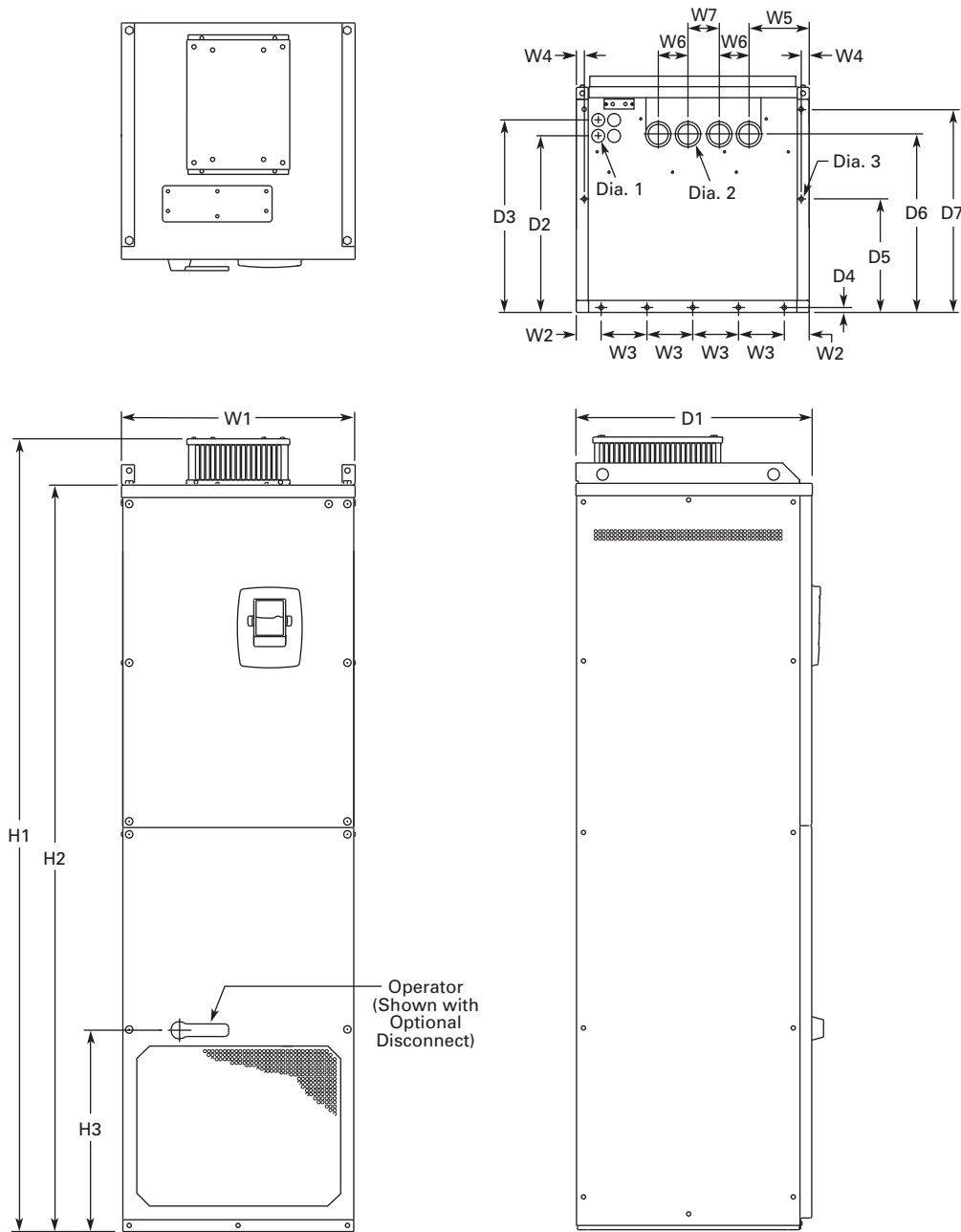

W1	W2	W3	W4	W5	W6	W7	H1	H2	H3	D1	D2	D3	D4	D5	D6	D7	Dia. 1	Dia. 2	Dia. 3	Weight Lbs (kg)
23.43 (595)	2.46 (62.5)	4.53 (115)	0.79 (20)	5.95 (151)	2.95 (75)	30.11 (79)	79.45 (2018)	74.80 (1900)	20.18 (512.5)	23.70 (602)	17.44 (443)	19.02 (483)	0.47 (12)	11.22 (285)	17.60 (447)	20.08 (510)	0.83 (21)	1.89 (48)	0.43 (11)	857 (389)

# 36.3

## Adjustable Frequency Drives

### SVX9000 Drives

Approximate Dimensions in Inches (mm)

#### FR10 Open Chassis ①

36

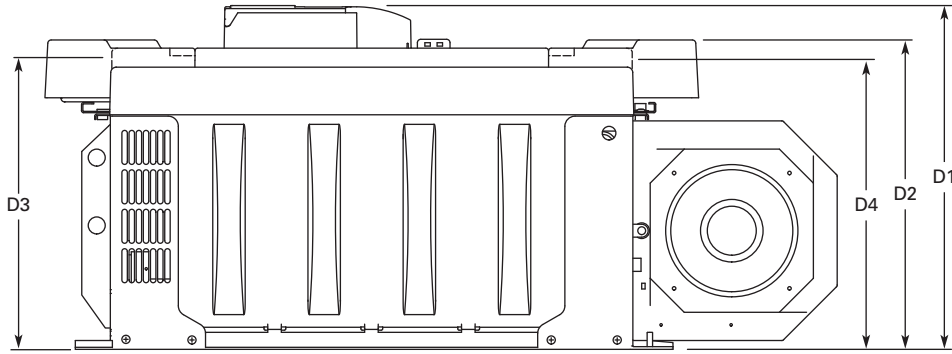
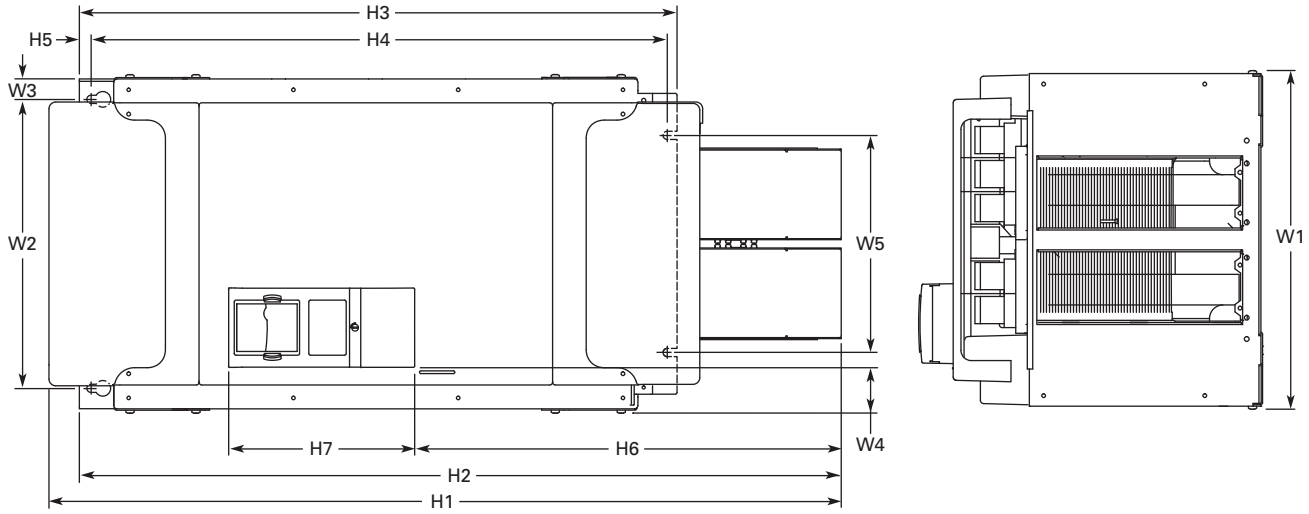

Voltage	hp (I <sub>H</sub> )	W1	W2	W3	W4	W5	H1	H2	H3	H4	H5	H6	H7	D1	D2	D3	D4	Weight Lbs (kg)
480V	250-350	19.7 (500)	16.7 (425)	1.2 (30)	2.6 (67)	12.8 (325)	45.9 (1165)	44.1 (1121)	34.6 (879)	33.5 (850)	0.7 (17)	24.7 (627)	10.8 (275)	19.9 (506)	17.9 (455)	16.7 (423)	16.6 (421)	518 (235)
575V	200-300																	

**Note**

① 9000X FR12 is built of two FR10 modules. Please refer to SPX9000 installation manual for mounting instructions.

Approximate Dimensions in Inches (mm)

**NEMA Type 1/IP21, FR11 Freestanding Drive**

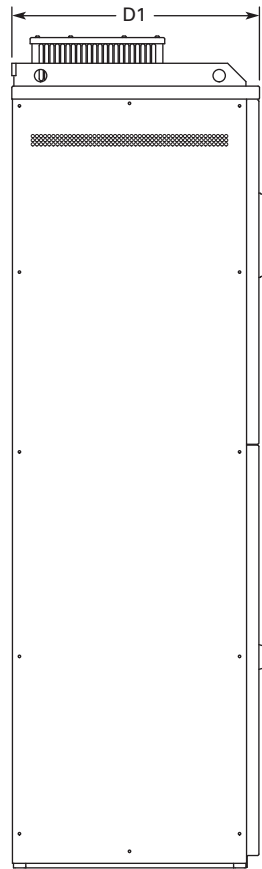
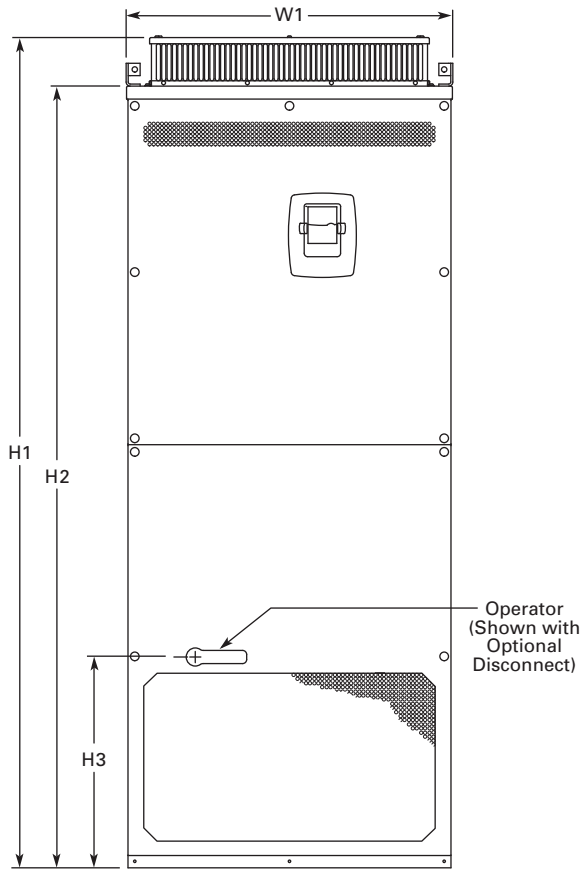
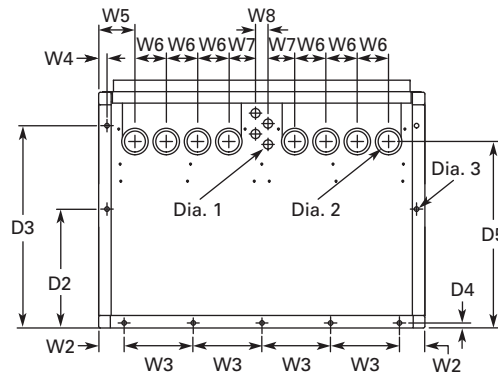
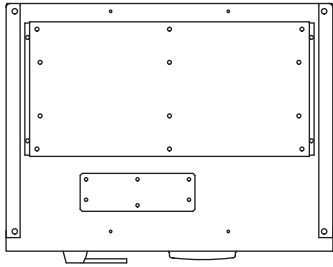

Voltage	hp (I <sub>H</sub> )	W1	W2	W3	W4	W5	W6	W7	W8	H1	H2	H3	D1	D2	D3	D4	D5	Dia. 1	Dia. 2	Dia. 3	Weight Lbs (kg)
480	400-550	31.26 (794)	2.40 (61)	6.50 (165)	0.79 (20)	3.43 (87)	2.95 (75)	2.52 (64)	1.18 (30)	79.45 (2018)	74.80 (1900)	20.18 (512.5)	23.70 (602)	11.22 (285)	19.09 (485)	0.47 (12)	17.60 (447)	0.83 (21)	1.89 (48)	0.35 x 0.43 (9 x 11)	526 (239)

# 36.3 Adjustable Frequency Drives

## SVX9000 Drives

Approximate Dimensions in Inches (mm)

### FR11 Open Chassis

36

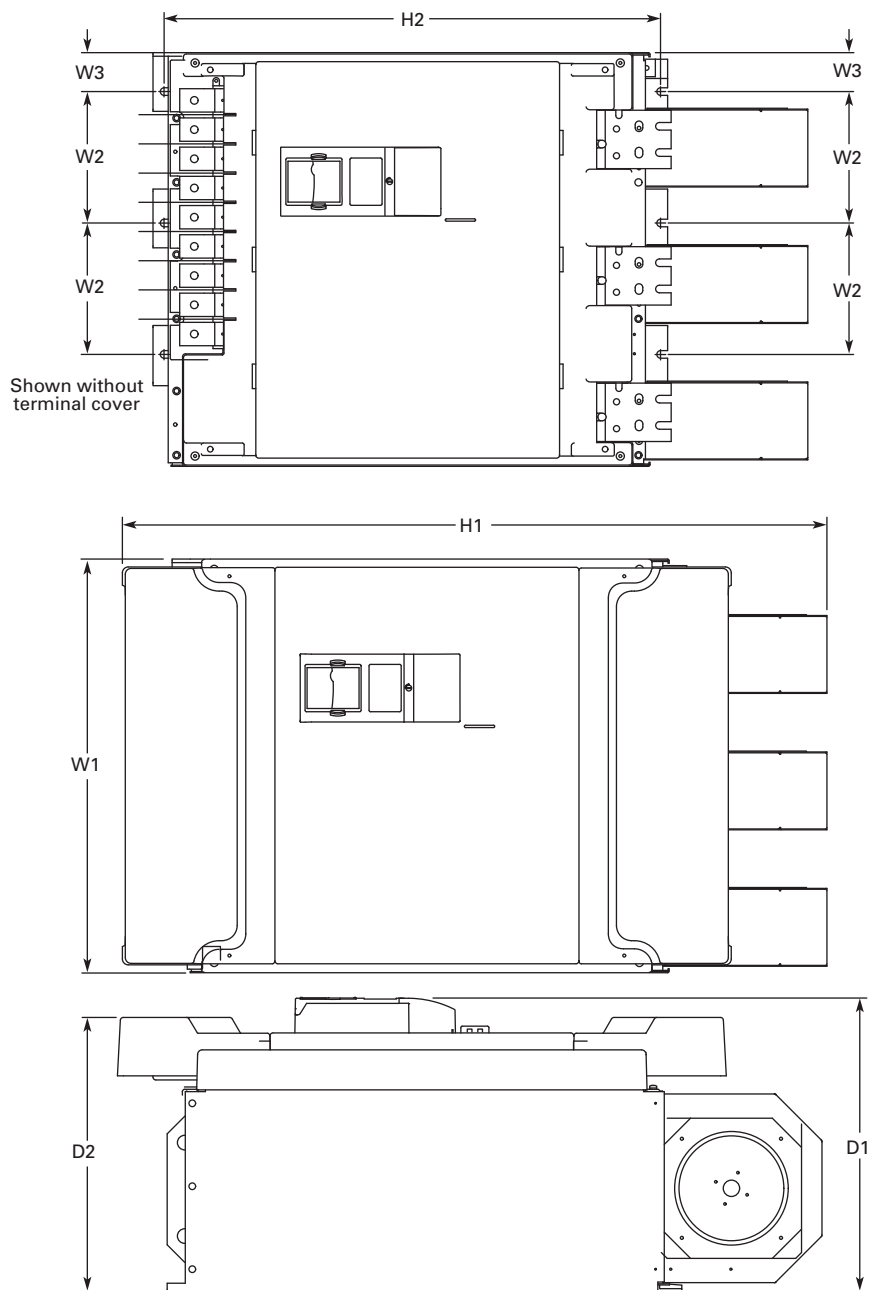

Voltage	hp (I <sub>H</sub> )	W1	W2	W3	H1	H2	D1	D2	Weight Lbs (kg)
480V	400-550	27.9 (709)	8.86 (225)	2.6 (67)	45.5 (1155)	33.5 (850)	19.8 (503)	18.4 (468)	833 (378)
575V	400-500								

Approximate Dimensions in Inches (mm)

### FR13, Open Chassis Inverter

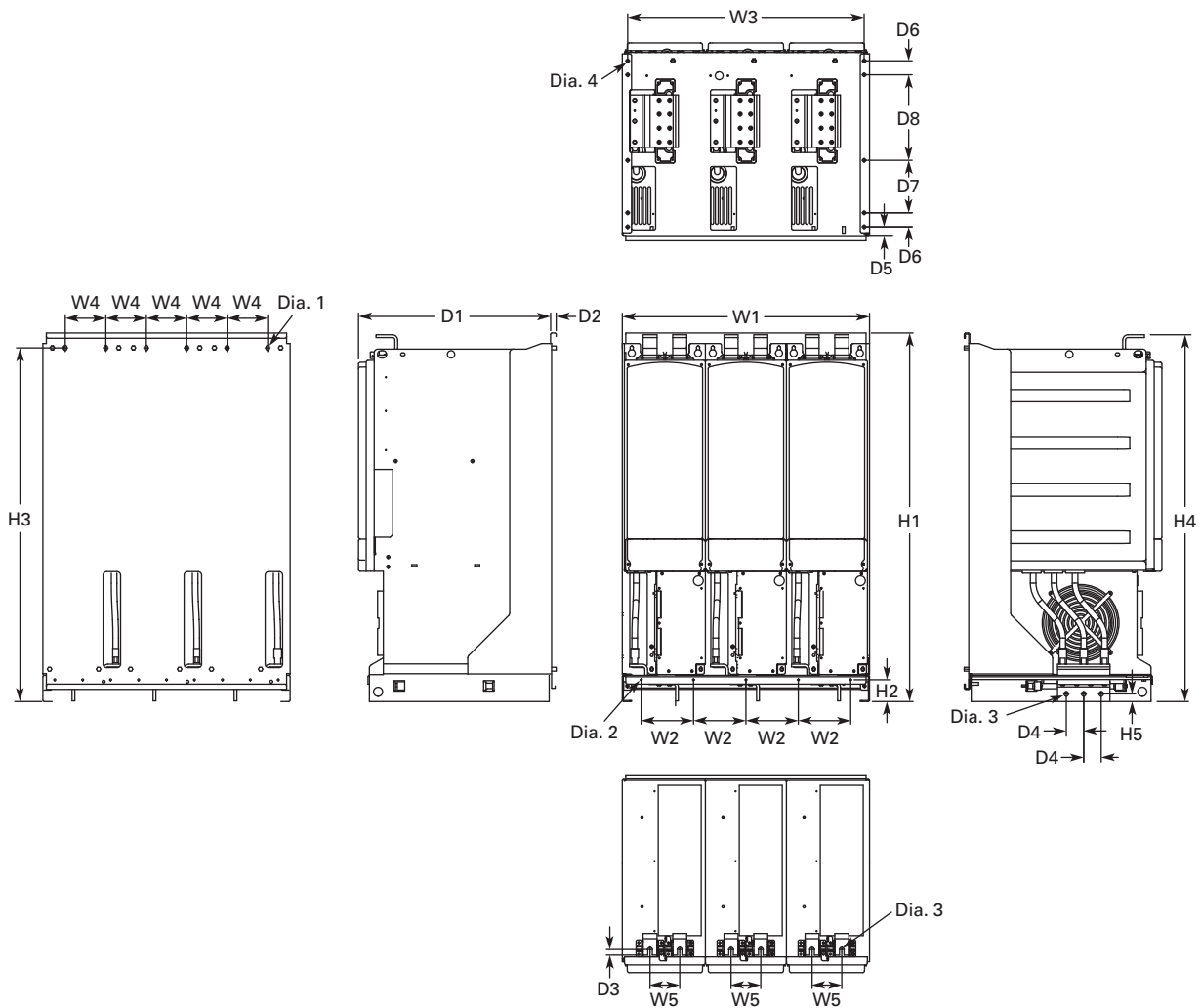

W1	W2	W3	W4	W5	H1	H2	H3	H4	H5	D1	D2	D3	D4	D5	D6	D7	D8	Dia. 1	Dia. 2	Dia. 3	Dia. 4	Weight Lbs (kg)
27.87 (708)	5.91 (150)	26.65 (677)	4.57 (116)	3.35 (85)	41.54 (1055)	2.46 (62.5)	39.86 (1012.5)	41.34 (1050)	0.79 (20)	21.77 (553)	0.51 (13)	0.63 (16)	1.97 (50)	1.06 (27)	1.57 (40)	5.91 (150)	9.64 (244.8)	0.35x0.59 (9x15)	0.18 (4.6)	0.51 (13)	0.37 (9.5)	683 (310)

#### Notes

9000X FR14 is built of two FR13 modules. Please refer to SPX9000 installation manual for mounting instructions.

FR13 is built from an inverter module and a converter module. Please refer to SPX9000 installation manual for mounting instructions.

# 36.3

## Adjustable Frequency Drives

### SVX9000 Drives

Approximate Dimensions in Inches (mm)

#### FR13, Open Chassis Converter

36

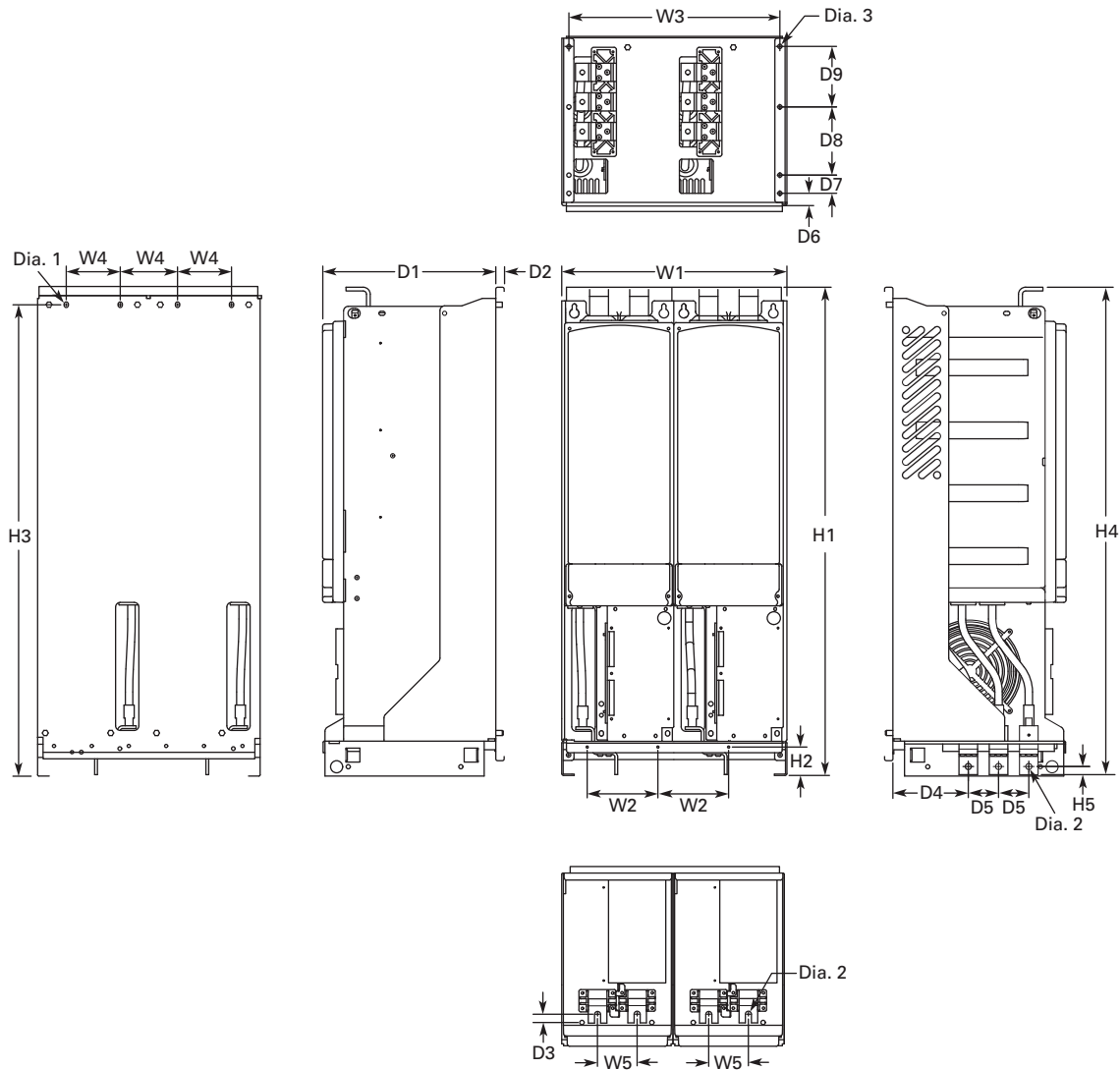

W1	W2	W3	W4	W5	H1	H2	H3	H4	H5	D1	D2	D3	D4	D5	D6	D7	D8	D9	Dia. 1	Dia. 2	Dia. 3	Weight Lbs (kg)
18.74 (476)	5.91 (150)	17.52 (445)	4.57 (116)	3.35 (85)	41.54 (1055)	2.46 (62.5)	39.86 (1012.5)	41.34 (1050)	0.69 (17.5)	14.69 (373)	0.51 (13)	0.73 (18.5)	6.42 (163)	2.56 (65)	1.06 (27)	1.57 (40)	5.91 (150)	5.24 (133)	0.35x0.59 (9x15)	0.51 (13)	0.37 (9.5)	295 (134)

#### Number of Input Units

480V Catalog Number	hp	Input Modules
SPX800A0-4A2N1	800	2

690V Catalog Number	hp	Input Modules
SPX800A0-5A2N1	800	2
SPX900A0-5A2N1	900	2
SPXH10A0-5A2N1	1000	2

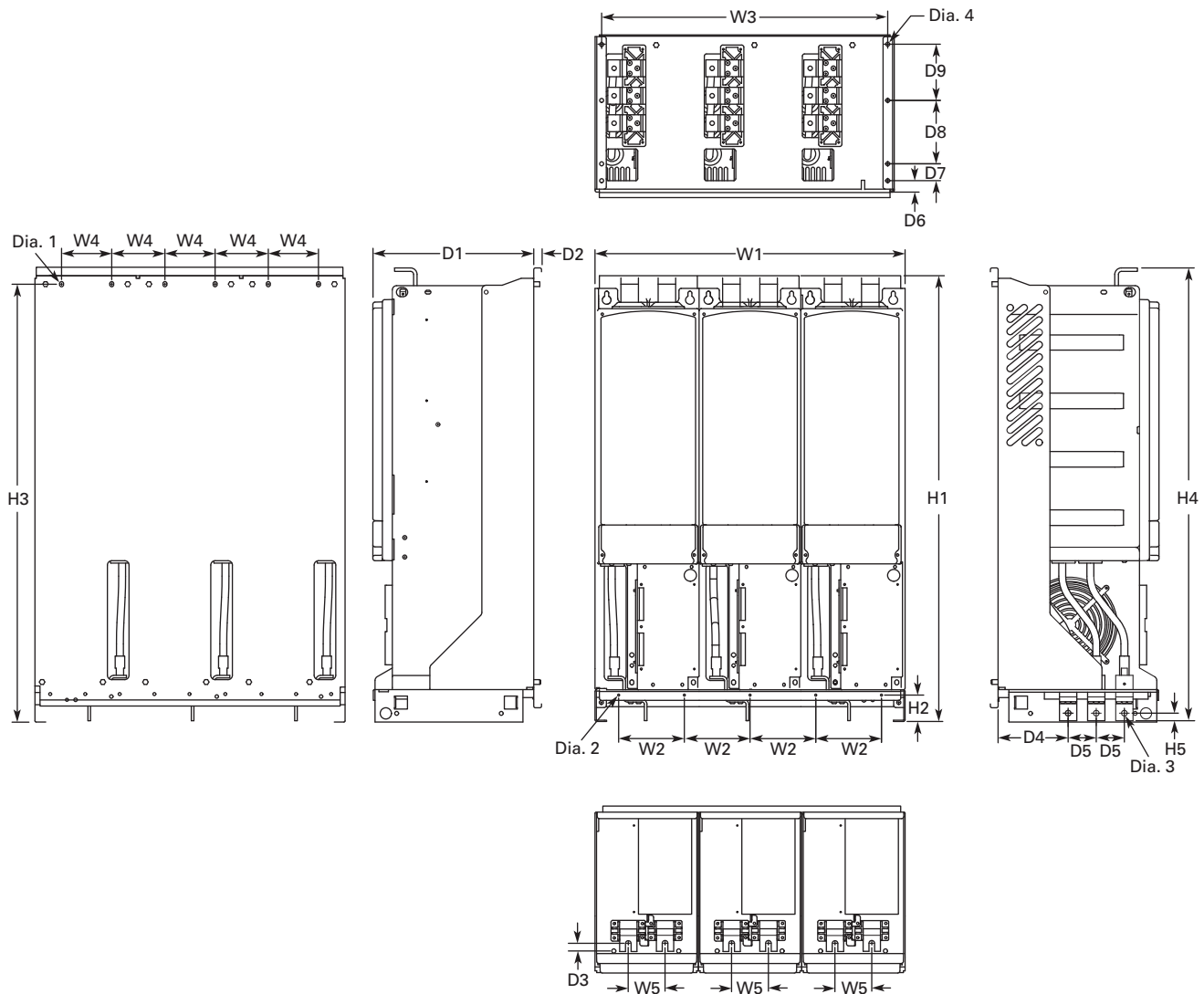

Approximate Dimensions in Inches (mm)

**FR13, Open Chassis Converter—900/1000 hp 480V**

W1	W2	W3	W4	W5	H1	H2	H3	H4	H5	D1	D2	D3	D4	D5	D6	D7	D8	D9	Dia. 1	Dia. 2	Dia. 3	Dia. 4	Weight Lbs (kg)
27.87 (708)	5.91 (150)	26.65 (677)	4.57 (116)	3.35 (85)	41.54 (1055)	2.46 (62.5)	39.86 (1012.5)	41.34 (1050)	0.69 (17.5)	14.69 (373)	0.51 (13)	0.73 (18.5)	6.42 (163)	2.56 (65)	1.06 (27)	1.57 (40)	5.91 (150)	5.24 (133)	0.35x0.59 (9x15)	0.18 (4.6)	0.51 (13)	0.37 (9.5)	443 (201)

**Number of Input Units**

480V Catalog Number	hp	Input Modules
SPX900A0-4A2N1	900	3
SPXH10A0-4A2N1	1000	3

# 36.3

## Adjustable Frequency Drives

### SVX9000 Drives

Approximate Dimensions in Inches (mm)

36

#### AC Choke Dimensions

##### Choke Types

Catalog Number	Frame Size	Choke Type ①	Catalog Number	Frame Size	Choke Type ①
<b>Voltage Range 380–500V</b>			<b>Voltage Range 525–690V</b>		
SPX 250 4	FR10	CHK0400	SPX 200 5	FR10	CHK0261
SPX 300 4		CHK0520	SPX 250 5		CHK0400
SPX 350 4		CHK0520	SPX 300 5		CHK0400
SPX 400 4	FR11	2 x CHK0400	SPX 400 5	FR11	CHK0520
SPX 500 4		2 x CHK0400	SPX 450 5		CHK0520
SPX 550 4		2 x CHK0400	SPX 500 5		2 x CHK0400
SPX 600 4	FR12	2 x CHK0520	SPX 550 5	FR12	2 x CHK0400
SPX 650 4		2 x CHK0520	SPX 600 5		2 x CHK0400
SPX 700 4		2 x CHK0520	SPX 700 5		2 x CHK0400
SPX 800 4	FR13	2 x CHK0400	SPX 800 5	FR13	2 x CHK0400
SPX 900 4		3 x CHK0520	SPX 900 5		2 x CHK0400
SPX H10 4		3 x CHK0520	SPX H10 5		2 x CHK0400
SPX H12 4	FR14	4 x CHK0520	SPX H13 5	FR14	4 x CHK0400
SPX H16 4		6 x CHK0400	SPX H15 5		6 x CHK0400

#### CHK0520

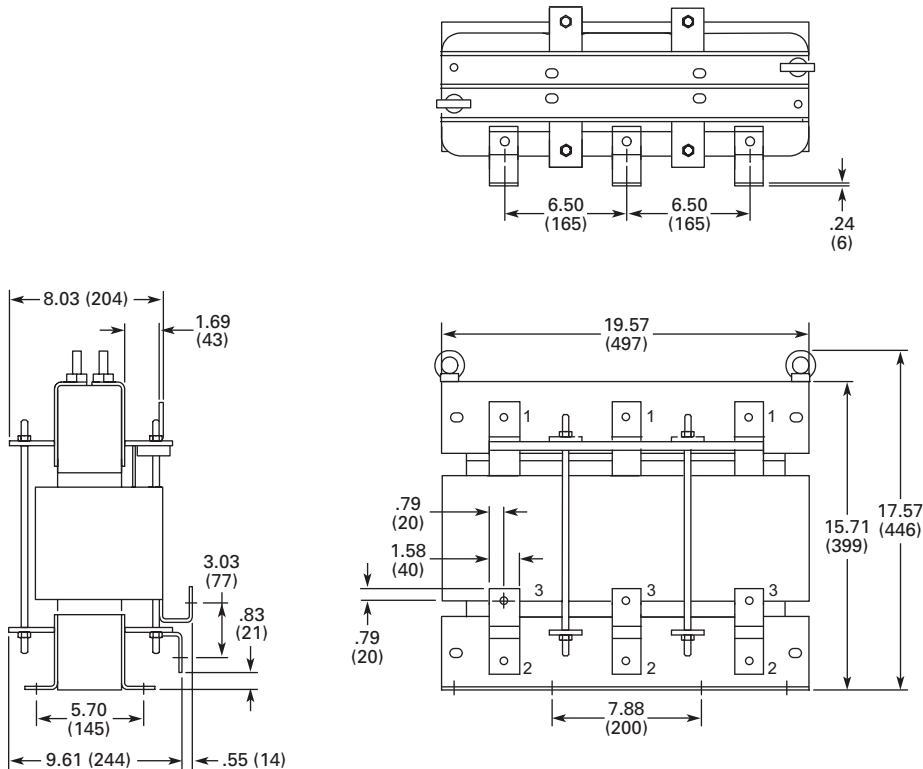

#### Note

① Chokes are provided with all FR10–FR14 drives.

Approximate Dimensions in Inches (mm)

## CHK0400

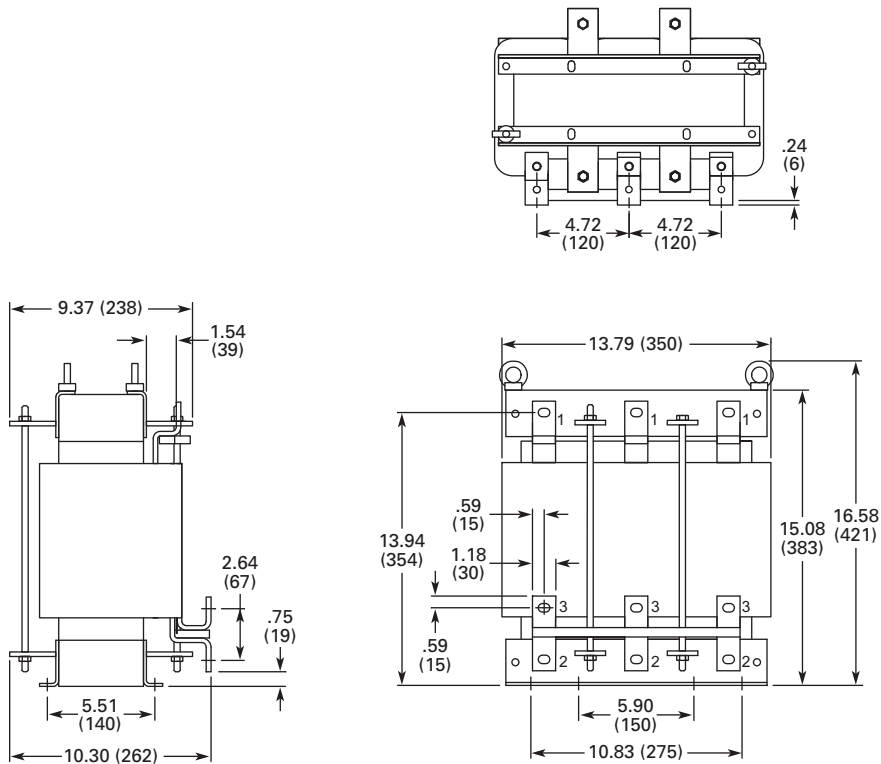

## CHK0261

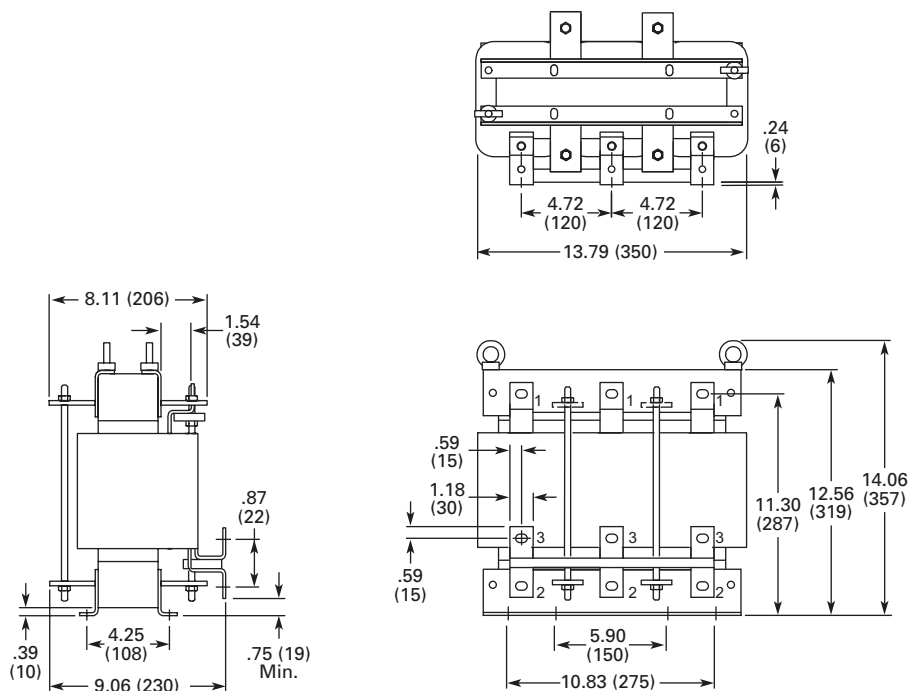

SVX9000 Enclosed Drives

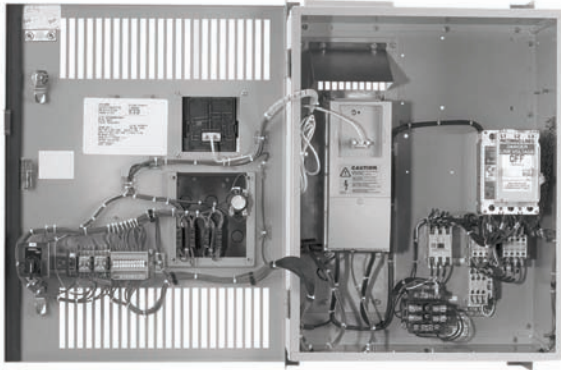

### Contents

<b>Description</b>	<b>Page</b>
SVX9000 Open Drives .....	<b>V6-T36-17</b>
SVX9000 Enclosed Drives	
Product Identification .....	<b>V6-T36-53</b>
Catalog Number Selection .....	<b>V6-T36-54</b>
Product Selection .....	<b>V6-T36-55</b>
Options .....	<b>V6-T36-59</b>
Technical Data and Specifications .....	<b>V6-T36-65</b>
Wiring Diagram .....	<b>V6-T36-66</b>
Dimensions .....	<b>V6-T36-67</b>
SVX9000 VFD Pump Panels .....	<b>V6-T36-78</b>

### SVX9000 Enclosed Drives

#### Product Description

- **Standard Enclosed**—covers a wide range of the most commonly ordered options. Pre-engineering eliminates the lead time normally associated with customer specific options.
- **Modified Standard Enclosed**—applies to specific customer requirements that vary from the standard enclosed offering, such as the need for an additional indicating light or minor modifications to drawings. *Consult your Eaton representative for assistance in pricing and lead time.*
- **Custom Engineered**—for those applications with more unique or complex requirements, these are individually engineered to the customer’s needs. *Consult your Eaton representative for assistance in pricing and lead time.*

#### Features

- NEMA Type 1/IP21 or NEMA Type 12/IP54 enclosures
- Input voltage: 208V, 230V, 480V and 575V (consult factory)
- Complete range of control, network and power options
- Horsepower range:
  - 208V—3/4 to 100 hp I<sub>H</sub>; 1 to 100 hp I<sub>L</sub>
  - 230V—3/4 to 100 hp I<sub>H</sub>; 1 to 100 hp I<sub>L</sub>
  - 480V—1 to 700 hp I<sub>H</sub>; 1-1/2 to 800 hp I<sub>L</sub>
- HMCP padlockable

#### Standards and Certifications

- UL Listed
- cUL Listed

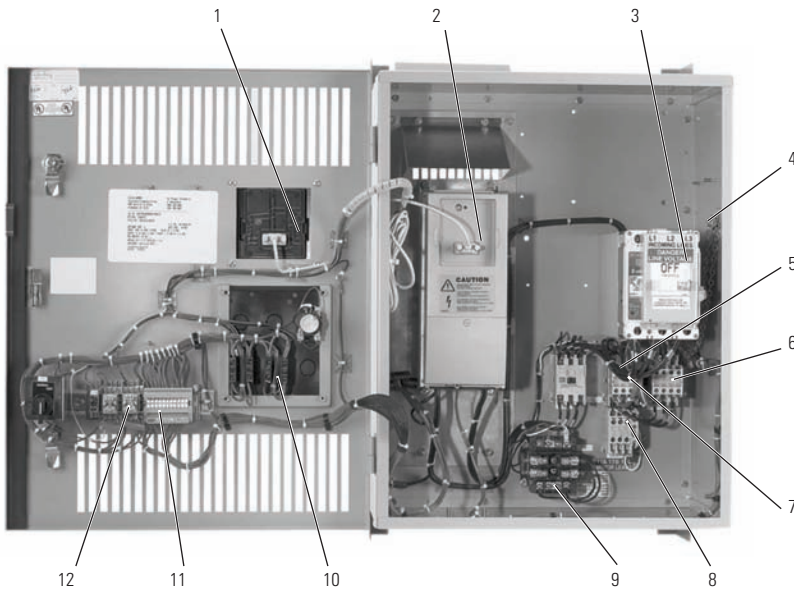

**Product Identification****Enclosed 9000X Series Drive**

- |  |   |   |
|--|---|---|
| <p>1 Door mounted keypad (included as standard with bypass option)</p> <p>2 SVX9000 variable frequency drive</p> <p>3 Input disconnect (HMCP)<br/>• Option P1</p> <p>4 Input line fuses<br/>• Option P3</p> <p>5 Input contactor (included as standard with bypass option)</p> | <p>6 Output contactor<br/>• Option PE (included as standard with bypass option)</p> <p>7 Bypass contactor<br/>• Option RB<br/>• Option RA</p> <p>8 Overload relay<br/>• Option PH<br/>• Option PI</p> | <p>9 115V control transformer<br/>• Option KB</p> <p>10 Bypass pilot lights and selector switches<br/>• Option RB<br/>• Option RA<br/>• Option L2<br/>• Option KF</p> <p>11 Customer control and signal connection terminal block</p> <p>12 Control relay</p> |
|--|---|---|

#### Catalog Number Selection

#### SVX9000 Enclosed NEMA Type 1/IP21 and NEMA Type 12/IP54 Drives

36

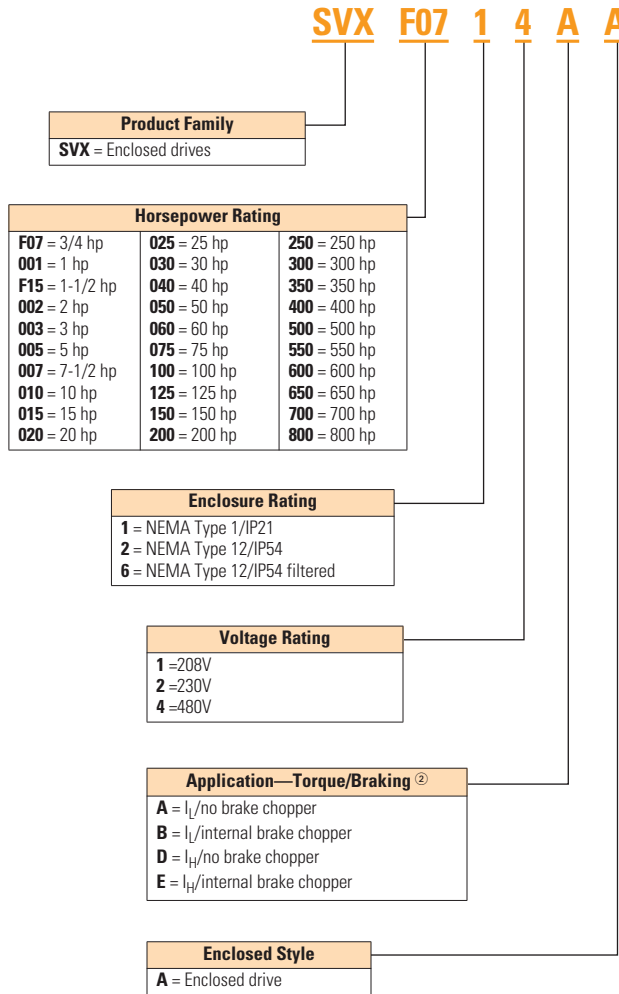

Build Alphabetically and Numerically

Enclosed Options <sup>①④⑤</sup>		Type
<b>K1</b>	Door-mounted speed potentiometer <sup>③</sup>	Control
<b>K2</b>	Door-mounted speed potentiometer with HOA selector switch <sup>③</sup>	Control
<b>K3</b>	3–15 psig follower	Control
<b>K4</b>	HAND/OFF/AUTO switch (22 mm)	Control
<b>K5</b>	MANUAL/AUTO ref switch (22 mm)	Control
<b>K6</b>	START/STOP pushbuttons (22 mm)	Control
<b>KB</b>	115V control transformer (550 VA)	Control
<b>KF</b>	Bypass test switch for RA and RB	Addl. bypass
<b>KO</b>	Standard elapsed time meter	Control
<b>L1</b>	Power on and fault pilot lights	Light
<b>L2</b>	Bypass pilot lights for RA, RB bypass options	Addl. bypass
<b>LA</b>	Green RUN light (22 mm)	Light
<b>LD</b>	Green STOP light (22 mm)	Light
<b>LE</b>	Red RUN light	Light
<b>LF</b>	Red STOP light (22 mm)	Light
<b>LJ</b>	White power on light (22 mm)	Light
<b>LU</b>	Misc. light (22 mm)	Light
<b>P1</b>	Input disconnect (HMCP) 100 kAIC	Input
<b>P2</b>	Disconnect switch <sup>②</sup>	Input
<b>P3</b>	Input line fuses (200 kAIC)	Input
<b>P7</b>	Input power surge protection	Input
<b>PE</b>	Output contactor	Output
<b>PF</b>	Output filter	Output
<b>PG</b>	MotoRx (up to 600 ft) 1000 V/μS DV/DT filter	Output
<b>PH</b>	Single overload relay	Output
<b>PI</b>	Dual overload relays	Output
<b>PN</b>	Dual overloads for bypass	Addl. bypass
<b>RA</b>	Manual HOA bypass controller	Bypass
<b>RB</b>	Manual IOB bypass controller	Bypass
<b>RC</b>	Auto transfer HOA bypass controller	Bypass
<b>RD</b>	Auto transfer IOB bypass controller	Bypass
<b>S5</b>	Floor stand 22 in	Enclosure
<b>S6</b>	Floor stand 12 in	Enclosure
<b>S7</b>	10 in expansion	Enclosure
<b>S8</b>	20 in expansion	Enclosure
<b>S9</b>	Space heater	Enclosure
Communication Options <sup>⑥</sup>		
<b>C2</b> = Modbus	<b>C6</b> = CanOpen (slave)	<b>CA</b> = Johnson Controls N2
<b>C3</b> = Profibus DP	<b>C7</b> = DeviceNet	<b>CI</b> = Modbus TCP
<b>C4</b> = LonWorks	<b>C8</b> = Modbus (D9 type connector)	<b>CJ</b> = BACnet
<b>C5</b> = Profibus DP (D9 connector)		<b>CK</b> = Ethernet IP
		<b>D3</b> = RS-232 with D9 connection
Control Options		
<b>B1</b> = 6 DI, 1 ext +24 Vdc/EXT +24 Vdc	<b>B5</b> = 3 RO (NO)	
<b>B2</b> = 1 RO (NC-NO), 1 RO (NO), 1 therm	<b>B8</b> = 1 ext +24 Vdc/EXT +24 Vdc, 3 Pt100	
<b>B4</b> = 1 AI (mA isolated), 2 AO (mA isolated), 1 ext +24 Vdc/EXT +24 Vdc	<b>B9</b> = 1 RO (NO), 5 DI 42–240 Vac input	
Engineered Options		
<b>HT</b>	High temperature rating for 50°C (FR10 and above) <sup>⑥</sup>	
<b>VB</b>	Varnished boards	

#### Notes

- ① Local/remote keypad is included as the standard control panel.
- ② Brake chopper is a factory installed option only, see drive options on **Page V6-T36-18**. External dynamic braking resistors not included. Consult factory.
- ③ Includes local/remote speed reference switch.
- ④ Some options are voltage and/or horsepower specific. Consult your Eaton representative for details.
- ⑤ See **Pages V6-T36-61** and **V6-T36-62** for descriptions.
- ⑥ See **Pages V6-T36-59** and **V6-T36-60** for complete descriptions.
- ⑦ Applicable only with FR10 and FR11 freestanding designs.
- ⑧ Consult Eaton for availability.

## Product Selection

### When Ordering

- Select a base catalog number that meets the application requirements—nominal horsepower, voltage and enclosure rating (the enclosed drive's continuous output amp rating should be equal to or greater than the motor's full load amp rating). The base enclosed package includes a standard drive, door mounted local/remote keypad and enclosure.
- If dynamic brake chopper or control/communication option is desired, change the appropriate code in the base catalog number.
- Select enclosed options. Add the codes as suffixes to the base catalog number in alphabetical and numeric order.
- **Read all footnotes.**

### 208V Drives

#### SVX9000 Enclosed Drives



#### Input Base Drives

Enclosure Size <sup>①</sup>	hp	Current (A)	NEMA Type 1/IP21		NEMA Type 12/IP54	
			Frame Size	Base Catalog Number <sup>②</sup>	Frame Size	Base Catalog Number <sup>②</sup>
<b>High Overload Drive and Enclosure</b>						
0	3/4	3.7	4	SVXF0711EA	4	SVXF0721EA
	1	4.8		SVX00111EA		SVX00121EA
	1-1/2	6.6		SVXF1511EA		SVXF1521EA
	2	7.8		SVX00211EA		SVX00221EA
	3	11		SVX00311EA		SVX00321EA
0	5	17.5	5	SVX00511EA	5	SVX00521EA
	7-1/2	25		SVX00711EA		SVX00721EA
1	10	31	6	SVX01011EA	6	SVX01021EA
	15	48		SVX01511EA		SVX01521EA
2	20	61	7	SVX02011DA	7	SVX02021DA
	25	75		SVX02511DA		SVX02521DA
	30	88		SVX03011DA		SVX03021DA
3	40	114	8	SVX04011DA	8	SVX04021DA
4	50	143	8	SVX05011DA	8	SVX05021DA
5	60	170	8	SVX06011DA	8	SVX06021DA
	75	211	9	SVX07511DA	9	SVX07521DA
	100	273		SVX10011DA		SVX10021DA
<b>Low Overload Drive and Enclosure</b>						
0	1	4.8	4	SVX00111BA	4	SVX00121BA
	1-1/2	6.6		SVXF1511BA		SVXF1521BA
	2	7.8		SVX00211BA		SVX00221BA
	3	11		SVX00311BA		SVX00321BA
	5	17.5	5	SVX00511BA	5	SVX00521BA
0	7-1/2	25		SVX00711BA		SVX00721BA
	10	31		SVX01011BA		SVX01021BA
1	15	48	6	SVX01511BA	6	SVX01521BA
	20	61		SVX02011BA		SVX02021BA
2	25	75	7	SVX02511AA	7	SVX02521AA
	30	88		SVX03011AA		SVX03021AA
	40	114		SVX04011AA		SVX04021AA
3	50	—	8	SVX05011AA	8	SVX05021AA
4	60	170	8	SVX06011AA	8	SVX06021AA
5	③	205 ③	8	SVX07511AA	8	SVX07521AA
	③	261 ③	9	SVX10011AA	9	SVX10021AA

#### Notes

For brake chopper options, see **Page V6-T36-63**.

① See enclosure dimensions starting on **Page V6-T36-67**.

② Includes drive, local/remote keypad and enclosure.

③ These units are current rated (75 I<sub>L</sub> hp 205 amps, 100 I<sub>L</sub> hp 261 amps). They are not hp rated.

#### 230V Drives

#### SVX9000 Enclosed Drives

#### Input Base Drives

36



Enclosure Size ①	hp	Current (A)	NEMA Type 1/IP21		NEMA Type 12/IP54		
			Frame Size	Base Catalog Number ②	Frame Size	Base Catalog Number ②	
<b>High Overload Drive and Enclosure</b>							
0	3/4	3.7	4	SVXF0712EA	4	SVXF0722EA	
	1	4.8		SVX00112EA		SVX00122EA	
	1-1/2	6.6		SVXF1512EA		SVXF1522EA	
	2	7.8	SVX00212EA	SVX00222EA			
	3	11	SVX00312EA	SVX00322EA			
	5	17.5	5	SVX00512EA		5	SVX00522EA
	7-1/2	25	SVX00712EA	SVX00722EA			
1	10	31	6	SVX01012EA	6	SVX01022EA	
	15	48		SVX01512EA		SVX01522EA	
2	20	61	7	SVX02012DA	7	SVX02022DA	
	25	75		SVX02512DA		SVX02522DA	
	30	88		SVX03012DA		SVX03022DA	
3	40	114	8	SVX04012DA	8	SVX04022DA	
4	50	140	8	SVX05012DA	8	SVX05022DA	
5	60	170	8	SVX06012DA	8	SVX06022DA	
	75	205		9		SVX07512DA	9
	100	261	SVX10012DA	SVX10022DA			
<b>Low Overload Drive and Enclosure</b>							
0	1	4.8	4	SVX00112BA	4	SVX00122BA	
	1-1/2	6.6		SVXF1512BA		SVXF1522BA	
	2	7.8		SVX00212BA		SVX00222BA	
	3	11	SVX00312BA	SVX00322BA			
	5	17.5	5	SVX00512BA		5	SVX00522BA
	7-1/2	25	SVX00712BA	SVX00722BA			
	10	31	SVX01012BA	SVX01022BA			
1	15	48	6	SVX01512BA	6	SVX01522BA	
	20	61		SVX02012BA		SVX02022BA	
2	25	75	7	SVX02512AA	7	SVX02522AA	
	30	88		SVX03012AA		SVX03022AA	
	40	114		SVX04012AA		SVX04022AA	
3	50	140	8	SVX05012AA	8	SVX05022AA	
4	60	170	8	SVX06012AA	8	SVX06022AA	
5	75	205	8	SVX07512AA	8	SVX07522AA	
	③	261 ③		9		SVX10012AA	9

#### Notes

For brake chopper options, see **Page V6-T36-63**.

① See enclosure dimensions starting on **Page V6-T36-67**.

② Includes drive, local/remote keypad and enclosure.

③ This unit is current rated (100 I<sub>L</sub> hp 100 amps, 261 I<sub>L</sub> hp). It is not hp rated.



## 480V Drives

## SVX9000 Enclosed Drives



## Input Base Drives

Enclosure Size ①	hp	Current (A)	NEMA Type 1/IP21		NEMA Type 12/IP54	
			Frame Size	Base Catalog Number ②	Frame Size	Base Catalog Number ②
<b>High Overload Drive and Enclosure</b>						
0	1	2.2	4	SVX00114EA	4	SVX00124EA
	1-1/2	3.3		SVXF1514EA		SVXF1524EA
	2	4.3		SVX00214EA		SVX00224EA
	3	5.6		SVX00314EA		SVX00324EA
	5	7.6	SVX00514EA	SVX00524EA		
	7-1/2	12	5	SVX00714EA		SVX00724EA
	10	16		SVX01014EA		SVX01024EA
	15	23		SVX01514EA		SVX01524EA
1	20	31	6	SVX02014EA	6	SVX02024EA
	25	38		SVX02514EA		SVX02524EA
	30	46		SVX03014EA		SVX03024EA
2	40	61	7	SVX04014DA	7	SVX04024DA
	50	72		SVX05014DA		SVX05024DA
	60	87		SVX06014DA		SVX06024DA
3	75	105	8	SVX07514DA	8	SVX07524DA
	100	140		SVX10014DA		SVX10024DA
4	125	170	8	SVX12514DA	8	SVX12524DA
5	150	205	9	SVX15014DA	9	SVX15024DA
	200	245		SVX20014DA		SVX20024DA
6, 8 ③④	250	300	10	SVX25014DA	10	SVX25064DA
	300	385		SVX30014DA		SVX30064DA
	350	460		SVX35014DA		SVX35064DA
8, 9 ④⑤	400	520	11	SVX40014DA	11	SVX40064DA
	500	590		SVX50014DA		SVX50064DA
	550	650		SVX55014DA		SVX55064DA
⑥	600	730	12	SVX60014DA	12	SVX60064DA
	650	820		SVX65014DA		SVX65064DA
	700	920		SVX70014DA		SVX70064DA

**Notes**

For brake chopper options, see **Page V6-T36-63**.

① See enclosure dimensions starting on **Page V6-T36-67**.

② Includes drive, local/remote keypad and enclosure.

③ The smaller enclosure Size 6 accommodates only power options, input disconnect (P1) and input line fuses (P3). Bypass and other options require Size 8. Adding any standard control option will not require the larger enclosure.

④ For other options, consult factory.

⑤ The smaller enclosure Size 8 accommodates only power options, input disconnect (P1) and input line fuses (P3). Bypass and other options require Size 9. Adding any standard control option will not require the larger enclosure.

⑥ Consult Eaton.

SVX9000 Enclosed Drives



#### Input Base Drives, continued

Enclosure Size ①	hp	Current (A)	NEMA Type 1/IP21		NEMA Type 12/IP54		
			Frame Size	Base Catalog Number ②	Frame Size	Base Catalog Number ②	
<b>Low Overload Drive and Enclosure</b>							
0	1-1/2	3.3	4	SVXF1514BA	4	SVXF1524BA	
	2	4.3		SVX00214BA		SVX00224BA	
	3	5.6		SVX00314BA		SVX00324BA	
	5	7.6		SVX00514BA		SVX00524BA	
	7-1/2	12	SVX00714BA	SVX00724BA			
	10	16	5	SVX01014BA		5	SVX01024BA
	15	23		SVX01514BA			SVX01524BA
20	31	SVX02014BA		SVX02024BA			
1	25	38	6	SVX02514BA	6	SVX02524BA	
	30	46		SVX03014BA		SVX03024BA	
	40	61		SVX04014BA		SVX04024BA	
2	50	72	7	SVX05014AA	7	SVX05024AA	
	60	87		SVX06014AA		SVX06024AA	
	75	105		SVX07514AA		SVX07524AA	
3	100	140	8	SVX10014AA	8	SVX10024AA	
4	125	170	8	SVX12514AA	8	SVX12524AA	
	150	205		SVX15014AA		SVX15024AA	
5	200	261	9	SVX20014AA	9	SVX20024AA	
	250	300		SVX25014AA		SVX25024AA	
6, 8 ③④	300	385	10	SVX30014AA	10	SVX30064AA	
	350	460		SVX35014AA		SVX35064AA	
	400	520		SVX40014AA		SVX40064AA	
8, 9 ④⑤	500	590	11	SVX50014AA	11	SVX50064AA	
	550	650		SVX55014AA		SVX55064AA	
	600	730		SVX60014AA		SVX60064AA	
⑥	650	820	12	SVX65014AA	12	SVX65064AA	
	700	920		SVX70014AA		SVX70064AA	
	800	1030		SVX80014AA		SVX80064AA	

**Notes**

For brake chopper options, see **Page V6-T36-63**.

① See enclosure dimensions starting on **Page V6-T36-67**.

② Includes drive, local/remote keypad and enclosure.

③ The smaller enclosure Size 6 accommodates only power options, input disconnect (P1) and input line fuses (P3). Bypass and other options require Size 8. Adding any standard control option will not require the larger enclosure.

④ For other options, consult factory.

⑤ The smaller enclosure Size 8 accommodates only power options, input disconnect (P1) and input line fuses (P3). Bypass and other options require Size 9. Adding any standard control option will not require the larger enclosure.

⑥ Consult Eaton.

## Options

### 9000X Series Option Board Kits

The 9000X Series drives can accommodate a wide selection of expander and adapter option boards to customize the drive for your application needs. The drive's control unit is designed to accept a total of five option boards.

The 9000X Series factory installed standard board configuration includes an A9 I/O board and an A2 relay output board, which are installed in slots A and B.

#### Option Boards

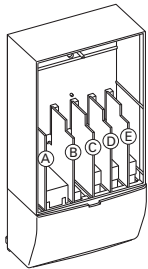

#### Option Board Kits

Option Kit Description <sup>①</sup>	Allowed Slot Locations <sup>②</sup>	Field Installed Catalog Number	Factory Installed Option Designator	SVX Ready Programs						
				Basic	Local/Remote	Standard	MSS	PID	Multi-P.	PFC
<b>Standard I/O Cards</b>										
2 RO (NC-NO)	B	<b>OPTA2</b>	—	■	■	■	■	■	■	■
6 DI, 1 DO, 2 AI, 1AO, 1 +10 Vdc ref, 2 ext +24 Vdc/EXT +24 Vdc	A	<b>OPTA9</b>	—	■	■	■	■	■	■	■
<b>Extended I/O Cards</b>										
2 RO, therm—SPX only	B	<b>OPTA3</b>	<b>A3</b>	—	■	■	■	■	■	■
Encoder low volt +5V/15V/24V—SPX only	C	<b>OPTA4</b>	<b>A4</b>	—	■	■	■	■	■	■
Encoder high volt +15V/24V—SPX only	C	<b>OPTA5</b>	<b>A5</b>	—	■	■	■	■	■	■
Double encoder—SPX only	C	<b>OPTA7</b>	<b>A7</b>	■	■	■	■	■	■	■
6 DI, 1 DO, 2 AI, 1 AO—SPX only	A	<b>OPTA8</b>	<b>A8</b>	—	■	■	■	■	■	■
3 DI (encoder 10–24V), out +15V/+24V, 2 DO (pulse+direction)—SPX only	C	<b>OPTAE</b>	<b>AE</b>	■	■	■	■	■	■	■
6 DI, 1 ext +24 Vdc/EXT +24 Vdc	B, C, <b>D</b> , E	<b>OPTB1</b>	<b>B1</b>	—	—	—	—	—	■	■
1 RO (NC-NO), 1 RO (NO), 1 therm	B, C, <b>D</b> , E	<b>OPTB2</b>	<b>B2</b>	—	—	—	—	—	■	■
1 AI (mA isolated), 2 AO (mA isolated), 1 ext +24 Vdc/EXT +24 Vdc	B, C, <b>D</b> , E	<b>OPTB4</b>	<b>B4</b>	■	■	■	■	■	■	■
3 RO (NO)	B, C, <b>D</b> , E	<b>OPTB5</b>	<b>B5</b>	—	—	—	—	—	■	■
1 ext +24 Vdc/EXT +24 Vdc, 3 Pt100	B, C, <b>D</b> , E	<b>OPTB8</b>	<b>B8</b>	—	—	—	—	—	—	—
1 RO (NO), 5 DI 42–240 Vac input	B, C, <b>D</b> , E	<b>OPTB9</b>	<b>B9</b>	—	—	—	—	—	■	■
<b>Communication Cards <sup>③</sup></b>										
Modbus	D, <b>E</b>	<b>OPTC2</b>	<b>C2</b>	■	■	■	■	■	■	■
Modbus TCP	D, <b>E</b>	<b>OPTCI</b>	<b>CI</b>	■	■	■	■	■	■	■
BACnet	D, <b>E</b>	<b>OPTCJ</b>	<b>CJ</b>	■	■	■	■	■	■	■
Ethernet IP	D, <b>E</b>	<b>OPTCK</b>	<b>CK</b>	■	■	■	■	■	■	■
Johnson Controls N2	D, <b>E</b>	<b>OPTC2</b>	<b>CA</b>	—	—	—	—	—	—	—
Profibus DP	D, <b>E</b>	<b>OPTC3</b>	<b>C3</b>	■	■	■	■	■	■	■
LonWorks	D, <b>E</b>	<b>OPTC4</b>	<b>C4</b>	■	■	■	■	■	■	■
Profibus DP (D9 connector)	D, <b>E</b>	<b>OPTC5</b>	<b>C5</b>	■	■	■	■	■	■	■
CanOpen (slave)	D, <b>E</b>	<b>OPTC6</b>	<b>C6</b>	■	■	■	■	■	■	■
DeviceNet	D, <b>E</b>	<b>OPTC7</b>	<b>C7</b>	■	■	■	■	■	■	■
Modbus (D9 type connector)	D, <b>E</b>	<b>OPTC8</b>	<b>C8</b>	■	■	■	■	■	■	■
Adapter—SPX only	D, <b>E</b>	<b>OPTD1</b>	<b>D1</b>	■	■	■	■	■	■	■
Adapter—SPX only	D, <b>E</b>	<b>OPTD2</b>	<b>D2</b>	■	■	■	■	■	■	■
RS-232 with D9 connection	D, <b>E</b>	<b>OPTD3</b>	<b>D3</b>	■	■	■	■	■	■	■
<b>Keypad</b>										
9000X Series local/remote keypad	—	<b>KEYPAD-LOC/REM</b>	—	—	—	—	—	—	—	—
9000X Series remote mount keypad kit (keypad not included)	—	<b>OPTRMT-KIT-9000X</b>	—	—	—	—	—	—	—	—
9000X Series RS-232 cable, 13 ft	—	<b>PP00104</b>	—	—	—	—	—	—	—	—

#### Notes

- ① AI = Analog Input; AO = Analog Output, DI = Digital Input, DO = Digital Output, RO = Relay Output  
 ② Option card must be installed in one of the slots listed for that card. Slot indicated in bold is the preferred location.  
 ③ OPTC2 is a multi-protocol option card.

### Modbus RTU Network Communications

The Modbus Network Card OPTC2 is used for connecting the 9000X Drive as a slave on a Modbus network. The interface is connected by a 9-pin DSUB connector (female) and the baud rate ranges from 300 to 19200 baud. Other communication parameters include an address range from 1 to 247; a parity of None, Odd or Even; and the stop bit is 1.

### Profibus Network Communications

The Profibus Network Card OPTC3 is used for connecting the 9000X Drive as a slave on a Profibus-DP network. The interface is connected by a 9-pin DSUB connector (female). The baud rates range from 9.6K baud to 12M baud, and the addresses range from 1 to 127.

### LonWorks Network Communications

The LonWorks Network Card OPTC4 is used for connecting the 9000X Drive on a LonWorks network. This interface uses Standard Network Variable Types (SNVT) as data types. The channel connection is achieved using a FTT-10A Free Topology transceiver via a single twisted transfer cable. The communication speed with LonWorks is 78 kBits/s.

### CanOpen (Slave) Communications

The CanOpen (Slave) Network Card OPTC6 is used for connecting the 9000X Drive to a host system. According to ISO11898 standard cables to be chosen for CAN bus should have a nominal impedance of 120 ohms, and specific line delay of nominal 5 nS/m. 120 ohms line termination resistors required for installation.

### DeviceNet Network Communications

The DeviceNet Network Card OPTC7 is used for connecting the 9000X Drive on a DeviceNet Network. It includes a 5.08 mm pluggable connector. Transfer method is via CAN using a two-wire twisted shielded cable with two-wire bus power cable and drain. The baud rates used for communication include 125K baud, 250K baud and 500K baud.

### Johnson Controls Metasys N2 Network Communications

The OPTC2 fieldbus board provides communication between the 9000X Drive and a Johnson Controls Metasys™ N2 network. With this connection, the drive can be controlled, monitored and programmed from the Metasys system. The N2 fieldbus is available as a factory installed option and as a field installable kit.

### Modbus/TCP Network Communications

The Modbus/TCP Network Card OPTC1 is used for connecting the 9000X Drive to Ethernet networks utilizing Modbus protocol. It includes an RJ-45 pluggable connector. This interface provides a selection of standard and custom register values to communicate drive parameters. The board supports 10 Mbps and 100 Mbps communication speeds. The IP address of the board is configurable over Ethernet using a supplied software tool.

### BACnet Network Communications

The BACnet Network Card OPTCJ is used for connecting the 9000X Drive to BACnet networks. It includes a 5.08 mm pluggable connector. Data transfer is Master-Slave/Token Passing (MS/TP) RS-485. This interface uses a collection of 30 Binary Value Objects (BVOs) and 35 Analog Value Objects (AVOs) to communicate drive parameters. The card supports 9.6, 19.2 and 38.4 Kbaud communication speeds and supports network addresses 1–127.

### Ethernet/IP Network Communications

The Ethernet/IP Network Card OPTCK is used for connecting the 9000X Drive to Ethernet/Industrial Protocol networks. It includes an RJ-45 pluggable connector. The interface uses CIP objects to communicate drive parameters (CIP is “Common Industrial Protocol”, the same protocol used by DeviceNet). The board supports 10 Mbps and 100 Mbps communication speeds. The IP address of the board is configurable by Static, BOOTP and DHCP methods.

## SVX Conversion Kit

### Frame 4–7 ①

Frame Size	Enclosure Size	Delivery Code	Catalog Number
FR4	0	FB10	OPTCON-SVXFR4-SZ00
	1		OPTCON-SVXFR4-SZ01
FR5	0	FB10	OPTCON-SVXFR5-SZ00
	1		OPTCON-SVXFR5-SZ01
FR6	1	FB10	OPTCON-SVXFR6-SZ01
	2		OPTCON-SVXFR6-SZ02
FR7	2	FB10	OPTCON-SVXFR7-SZ02

#### Note

① The kit consists of a flange kit, adapter plate(s), hardware, remote keypad kit and SVX9000 decal.

**Control/Communication Option Descriptions**

For availability, see Product Selection for base drive voltage required.

**Available Control/Communications Options**

Option	Description	Option Type
K1	<b>Door-Mounted Speed Potentiometer</b> —Provides the SVX9000 with the ability to adjust the frequency reference using a door-mounted potentiometer. This option uses the 10 Vdc reference to generate a 0–10V signal at the analog voltage input signal terminal. When the HOA bypass option is added, the speed is controlled when the HOA switch is in the HAND position. Without the HOA bypass option, a two-position switch (labeled local/remote) is provided on the keypad to select speed reference from the speed potentiometer or a remote speed signal.	Control
K2	<b>Door-Mounted Speed Potentiometer with HOA Selector Switch</b> —Provides the SVX9000 with the ability to start/stop and adjust the speed reference from door-mounted control devices or remotely from customer supplied inputs. In HAND position, the drive will start and the speed is controlled by the door-mounted speed potentiometer. The drive will be disabled in the OFF position. When AUTO is selected, the drive run and speed control commands are via user-supplied dry contact and 4–20 mA signal.	Control
K3	<b>3–15 PSIG Follower</b> —Provides a pneumatic transducer which converts a 3–15 psig pneumatic signal to either 0–8 Vdc or a 1–9 Vdc signal interface with the SVX9000. The circuit board is mounted on the inside of the front enclosure panel and connects to the user's pneumatic control system via 6 ft (1.8m) of flexible tubing and a 1/4 in (6.4 mm) brass tube union.	Control
K4	<b>HAND/OFF/AUTO Switch for Non-Bypass Configurations</b> —Provides a three-position selector switch that allows the user to select either a HAND or AUTO mode of operation. HAND mode is defaulted to k (keypad operation, and AUTO mode is defaulted to control from an external terminal source. These modes of operation can be configured via programming to allow for alternate combinations of start and speed sources. Start and speed sources include keypad, I/O and fieldbus.	Control
K5	<b>MANUAL/AUTO Speed Reference Switch</b> —Provides a door-mounted selector switch for MANUAL/AUTO speed reference.	Control
K6	<b>START/STOP Pushbuttons</b> —Provide door-mounted START and STOP pushbuttons for either bypass or non-bypass configurations.	Control
KB	<b>115V Control Transformer, 550 VA</b> —Provides a fused control power transformer with additional 550 VA at 115V for customer use.	Control
KF	<b>Bypass Test Switch for RB and RA</b> —Allows the user to energize the AF drive for testing while operating the motor on the bypass controller. The test switch is mounted on the inside of the enclosure door.	Addl. bypass
K0	<b>Standard Elapsed Time Meter</b> —Provides a door-mounted elapsed run time meter.	Control
L1	<b>Power On and Fault Pilot Lights</b> —Provide a white power on light that indicates power to the enclosed cabinet and a red fault light that indicates a drive fault has occurred.	Light
L2	<b>Bypass Pilot Lights for RB, RA Bypass Options</b> —A green light indicates when the motor is running in inverter mode and an amber light that indicates when the motor is running in bypass mode. The lights are mounted on the enclosure door, above the switches.	Addl. bypass
LA	<b>Green RUN Light (22 mm)</b> —Provides a green run light that indicates the drive is running.	Light
LD	<b>Green STOP Light (22 mm)</b> —Provides a green light that indicates the drive is stopped.	Light
LE	<b>Red RUN Pilot Light (22 mm)</b> —Provides a red run pilot light that indicates the drive is running.	Light
LF	<b>Red STOP Light (22 mm)</b> —Provides a red stop light that indicates the drive is stopped.	Light
LJ	<b>White Power On Light (22 mm)</b> —The 22 mm white light that illuminates when the drive assembly is powered.	Light
LU	<b>Misc. Light (22 mm)</b> —Provides a misc. "user defined" pilot light. User to define light function and color.	Light
P1	<b>Input Disconnect Assembly Rated to 100 kAIC</b> —High Interrupting Motor Circuit Protector (HMCP) that provides a means of short circuit protection for the power cables between it and the SVX9000, and protection from high-level ground faults on the power cable. Allows a convenient means of disconnecting the SVX9000 from the line and the operating mechanism can be padlocked in the OFF position. This is factory mounted in the enclosure.	Input
P2	<b>Disconnect Switch</b> —Disconnect switch option is applicable only with NEMA Type 1/IP21 and NEMA Type 12/IP54 freestanding drives. Allows a convenient means of disconnecting the SVX9000 from the line, and the operating mechanism can be padlocked in the OFF position. This is factory-mounted in the enclosure.	Input
P3	<b>Input Line Fuses Rated to 200 kAIC</b> —Provides high-level fault protection of the SVX9000 input power circuit from the load side of the fuses to the input side of the power transistors. This option consists of three 200 kA fuses, which are factory mounted in the enclosure.	Input
P7	<b>MOV Surge Suppressor</b> —Provides a Metal Oxide Varistor (MOV) connected to the line side terminals and is designed to clip line side transients.	Input
PE	<b>Output Contactor</b> —Provides a means for positive disconnection of the drive output from the motor terminals. The contactor coil is controlled by the drive's run or permissive logic. NC and NO auxiliary contacts rated at 10A, 600 Vac are provided for customer use. Bypass options <b>RB</b> and <b>RA</b> include an output contactor as standard. This option includes a low VA 115 Vac fused control power transformer and is factory mounted in the enclosure.	Output
PF	<b>Output Filter</b> —Used to reduce the transient voltage (DV/DT) at the motor terminals. The output filter is recommended for cable lengths exceeding 100 ft (30m) with a drive of 3 hp and above, for cable lengths of 33 ft (10m) with a drive of 2 hp and below, or for a drive rated at 525–690V. This option is mounted in the enclosure, and may be used in conjunction with a brake chopper circuit.	Output
PG	<b>MotoRx (300–600 ft) 1000 V/μS DV/DT Filter</b> —Used to reduce transient voltage (DV/DT) and peak voltages at the motor terminals. This option is comprised of a 0.5% line reactor, followed by capacitive filtering and an energy recovery/clamping circuit. Unlike the output filter (See option <b>PF</b> ), the MotoRx recovers most of the energy from the voltage peaks, resulting in a lower voltage drop to the motor, and therefore conserving power. This option is used when the distance between a single motor and the drive is 300–600 ft (91–183m). <i>This option can not be used with the brake chopper circuit. The output filter (option <b>PF</b>) should be investigated as an alternative.</i>	Output
PH	<b>Single Overload Relay</b> —Uses a bimetallic overload relay to provide additional overload current protection to the motor on configurations without bypass options. It is included with the bypass configurations for overload current protection in the bypass mode. The overload relay is mounted within the enclosure, and is manually resettable. Heater pack included.	Output

For availability, see Product Selection for base drive voltage required.

### Available Control/Communications Options, continued

Option	Description	Option Type
PI	<b>Dual Overload Relays</b> —This option is recommended when a single drive is operating two motors and overload current protection is needed for each of the motors. The standard configuration includes two bimetallic overload relays, each sized to protect a motor with 50% of the drive hp rating. For example, a 100 hp drive would include two overload relays sized to protect two 50 hp motors. The relays are mounted within the enclosure, and are manually resettable. Heater packs not included.	Output
PN	<b>Dual Overloads for Bypass</b> —This option is recommended when a single drive is operating two motors in the bypass mode and overload current protection is needed for each of the motors. The standard configuration includes two bimetallic overload relays, each sized to protect a motor with 50% of the drive hp rating. For example, a 100 hp drive would include two overload relays sized to protect two 50 hp motors. The relays are mounted within the enclosure, and are manually resettable.	Addl. bypass
RA	<b>Manual HOA Bypass Controller</b> —The manual HAND/OFF/AUTO (HOA)—3-contactor—bypass option provides a means of bypassing the SVX9000, allowing the AC motor to be operated at full speed directly from the AC supply line. This option consists of an input disconnect, a fused control power transformer, and a full voltage bypass starter with a door mounted HOA selector switch and an INVERTER/BYPASS switch. The HOA switch provides the ability to start and stop the drive in the inverter mode. For applications up to 100 hp, a Freedom Series IEC input contactor, a Freedom Series IEC output contactor, and a Freedom Series IEC starter with a bimetallic overload relay is included. For applications above 100 hp, an Advantage input contactor, an Advantage output contactor and an Advantage starter with electronic overload protection is included. The contactors are mechanically and electrically interlocked (see power diagram on <b>Page V6-T36-66</b> ).	Bypass
RB	<b>Manual IOB Bypass Controller</b> —The manual INVERTER/OFF/BYPASS (IOB)—3-contactor—bypass option provides a means of bypassing the SVX9000, allowing the AC motor to be operated at full speed directly from the AC supply line. This option consists of an input disconnect, a fused control power transformer, and a full voltage bypass starter with a door mounted IOB selector switch. For applications up to 100 hp, a Freedom Series IEC input contactor, a Freedom Series IEC output contactor, and a Freedom Series IEC starter with a bimetallic overload relay is included. For applications above 100 hp, an Advantage input contactor, an Advantage output contactor and an Advantage starter with electronic overload protection is included. The contactors are mechanically and electrically interlocked (see power diagram on <b>Page V6-T36-66</b> ).	Bypass
RC	<b>Auto Transfer HOA Bypass Controller</b> —The manual HAND/OFF/AUTO (HOA)—3-contactor—bypass option provides a means of bypassing the SVX9000, allowing the AC motor to be operated at full speed directly from the AC supply line. The circuitry provides an automatic transfer of the load to “across the line” operation after a drive trip. This option consists of an input disconnect, a fused control power transformer, and a full voltage bypass starter with a door mounted HOA selector switch and an INVERTER/BYPASS switch. The HOA switch provides the ability to start and stop the drive in either mode. For applications up to 100 hp, a Freedom Series IEC input contactor, a Freedom Series IEC output contactor, and a Freedom Series IEC starter with a bimetallic overload relay is included. For applications above 100 hp, an Advantage input contactor, an Advantage output contactor and an Advantage starter with electronic overload protection is included. The contactors are mechanically and electrically interlocked (see power diagram on <b>Page V6-T36-66</b> ). Door-mounted pilot lights are provided which indicate bypass or inverter operation. A green light indicates when the motor is running in inverter mode and an amber light indicates when the motor is running in bypass mode. <b>WARNING:</b> The motor may restart when the overcurrent relay is reset when operating in bypass, unless the IOB selector switch is turned to the OFF position.	Bypass
RD	<b>Auto Transfer IOB Bypass Controller</b> —The auto INVERTER/OFF/BYPASS (IOB)—3-contactor—bypass option provides a means of bypassing the SVX9000, allowing the AC motor to be operated at full speed directly from the AC supply line. The circuitry provides an automatic transfer of the load to “across the line” operation after a drive trip. This option consists of an input disconnect, a fused control power transformer, and a full voltage bypass starter with a door mounted IOB selector switch. For applications up to 100 hp, a Freedom Series IEC input contactor, a Freedom Series IEC output contactor, and a Freedom Series IEC starter with a bimetallic overload relay is included. For applications above 100 hp, an Advantage input contactor, an Advantage output contactor and an Advantage starter with electronic overload protection is included. The contactors are mechanically and electrically interlocked (see power diagram on <b>Page V6-T36-66</b> ). Door-mounted pilot lights are provided which indicate bypass or inverter operation. A green light indicates when the motor is running in inverter mode and an amber light indicates when the motor is running in bypass mode. <b>WARNING:</b> The motor may restart when the overcurrent relay is reset when operating in bypass, unless the IOB selector switch is turned to the OFF position.	Bypass
S5	<b>Floor Stand 22 in</b> —Converts a Size 1 or 2, normally wall mounted enclosure to a floor standing enclosure with a height of 22 in (558.8 mm).	Enclosure
S6	<b>Floor Stand 12 in</b> —Converts a Size 2, normally wall mounted enclosure to a floor standing enclosure with a height of 12 in (304.8 mm).	Enclosure
S7	<b>10 in Expansion</b> —In a Size 5 enclosure, the extension allows for bottom cable entry and additional space for customer mounted components. <b>NOTE:</b> Enclosure expansion rated NEMA Type 1/IP21 only.	Enclosure
S8	<b>20 in Expansion</b> —In a Size 5 enclosure, the extension allows for bottom cable entry and additional space for customer mounted components. When the output filter (option <b>PF</b> ) is selected for a drive using a Size 5 enclosure, this expansion box is required and included in the option pricing. Enclosure expansion rated NEMA Type 1/IP21 only.	Enclosure
S9	<b>Space Heater</b> —Prevents condensation from forming in the enclosure when the drive is inactive or in storage. Includes a thermostat for variable temperature control. A 200W heater is installed in enclosures 0 and 1, and a 400W heater is installed in enclosures 2–5. Requires a customer supplied 115V remote supply source.	Enclosure

**Enclosed Drive Options****Brake Chopper Options**

The brake chopper circuit option is used for applications that require dynamic braking. Dynamic braking resistors are not included with drive

purchase. Consult the factory for dynamic braking resistors which are supplied separately. Resistors are not UL Listed.

For brake chopper circuit selection and adder—NEMA Type 1/IP21, NEMA Type 12/IP54, consult the factory.

**Conformal (Varnished) Coating**<sup>②</sup>

Chassis Frame	Delivery Code
FR4	FP
FR5	FP
FR6	FP
FR7	FP
FR8	FP
FR9	FP
FR10	FP
FR11	FP
FR12	FP
FR13	FP
FR14	FP

**208V and 230V Control Options—3/4–100 hp**<sup>③</sup>

Description	Catalog Number Suffix
Door-mounted speed potentiometer	<b>K1</b>
Door-mounted speed potentiometer with HOA selector switch	<b>K2</b>
3–15 psig follower	<b>K3</b>
HAND/OFF/AUTO switch (22 mm)	<b>K4</b>
MANUAL/AUTO ref switch (22 mm)	<b>K5</b>
START/STOP pushbuttons (22 mm)	<b>K6</b>
115 Volt control transformer 550 VA	<b>KB</b>
Standard elapsed time meter	<b>K0</b>

**480V Control Options—1–800 hp**<sup>③</sup>

Description	Catalog Number Suffix
Door-mounted speed potentiometer	<b>K1</b>
Door-mounted speed potentiometer with HOA selector switch	<b>K2</b>
3–15 psig follower	<b>K3</b>
HAND/OFF/AUTO switch (22 mm)	<b>K4</b>
MANUAL/AUTO ref switch (22 mm)	<b>K5</b>
START/STOP pushbuttons (22 mm)	<b>K6</b>
115 Volt control transformer 550 VA	<b>KB</b>
Standard elapsed time meter	<b>K0</b>

**208V and 230V Light Options—3/4–100 hp**<sup>③</sup>

Description	Catalog Number Suffix
Power on/fault pilot lights (22 mm)	<b>L1</b>
Green RUN light (22 mm)	<b>LA</b>
Green STOP light (22 mm)	<b>LD</b>
Red RUN light (22 mm)	<b>LE</b>
Red STOP light (22 mm)	<b>LF</b>
Power on light (22 mm)	<b>LJ</b>
Misc. light (22 mm)	<b>LU</b>

**480V Light Options—1–800 hp**<sup>③</sup>

Description	Catalog Number Suffix
Power on/fault pilot lights (22 mm)	<b>L1</b>
Green RUN light (22 mm)	<b>LA</b>
Green STOP light (22 mm)	<b>LD</b>
Red RUN light (22 mm)	<b>LE</b>
Red STOP light (22 mm)	<b>LF</b>
Power on light (22 mm)	<b>LJ</b>
Misc. light (22 mm)	<b>LU</b>

**Notes**

- ① External dynamic braking resistors not included. Consult factory.  
 ② See Product Selection on **Pages V6-T36-55 to V6-T36-58**, 208V, 230V and 480V. Consult the factory for adder.  
 ③ Consult factory for adder information.

208V and 230V Bypass Options, 3/4–100 hp <sup>①②</sup>

Description	Catalog Number Suffix
Bypass test switch for RA, RB (and RC, RD—230V)	<b>KF</b>
Bypass pilot lights for RA, RB options	<b>L2</b>
Dual overloads for bypass	<b>PN</b>
Manual HOA bypass controller	<b>RA</b>
Manual IOB bypass controller	<b>RB</b>
Auto transfer HOA bypass controller	<b>RC</b>
Auto transfer IOB bypass controller	<b>RD</b>

480V Bypass Options, 1–800 hp <sup>①②</sup>

Description	Catalog Number Suffix
Bypass test switch for RA, RB, RC, RD	<b>KF</b>
Bypass pilot lights for RA, RB options	<b>L2</b>
Dual overloads for bypass	<b>PN</b>
Manual HOA bypass controller	<b>RA</b>
Manual IOB bypass controller	<b>RB</b>
Auto transfer HOA bypass controller	<b>RC</b>
Auto transfer IOB bypass controller	<b>RD</b>

208V and 230V Enclosure Options, Sizes 0–5 <sup>②</sup>

Description	Catalog Number Suffix
Floor stand 22 in (558.8 mm)	<b>S5</b>
Floor stand 12 in (304.8 mm)	<b>S6</b>
10 in (254 mm) expansion <sup>③</sup>	<b>S7</b>
20 in (508 mm) expansion	<b>S8</b>
Space heater <sup>④</sup>	<b>S9</b>

480V Enclosure Options, Sizes 0–9 <sup>②</sup>

Description	Catalog Number Suffix
Floor stand 22 in (558.8 mm)	<b>S5</b>
Floor stand 12 in (304.8 mm)	<b>S6</b>
10 in (254 mm) expansion <sup>③</sup>	<b>S7</b>
20 in (508 mm) expansion	<b>S8</b>
Space heater <sup>④</sup>	<b>S9</b>

**Notes**

- ① See **Page V6-T36-62** for details.
- ② Consult factory for adder information.
- ③ See **Page V6-T36-67** for dimensions.
- ④ Requires customer supplied 115 Vac supply.
- ⑤ Not required for 208V and 230V applications.
- ⑥ Output filter may be required whenever the distance from the drive to the motor exceeds 100 ft (30m). Refer to **Page V6-T36-61**, option **PF** for further details.”.
- ⑦ Heater packs not included.
- ⑧ Applicable with FR10 and FR11 freestanding designs only.

208V and 230V Power Options, 3/4–100 hp <sup>②</sup>

Description	Catalog Number Suffix
<b>Input</b>	
Input disconnect (HMCP) 100 kAIC	<b>P1</b>
Input line fuses 200 kAIC	<b>P3</b>
Input power surge protection	<b>P7</b>
<b>Output</b>	
Output contactor	<b>PE</b>
Output filter <sup>⑤⑥</sup>	<b>PF</b>
MotoRx (300–600 ft) 1000 V/μs DV/DT filter <sup>⑥</sup>	<b>PG</b>
Single overload relay <sup>⑦</sup>	<b>PH</b>
Dual overload relays <sup>⑦</sup>	<b>PI</b>

480V Power Options, 1–800 hp <sup>②</sup>

Description	Catalog Number Suffix
<b>Input</b>	
Input disconnect (HMCP) 100 kAIC	<b>P1</b>
Input line fuses 200 kAIC	<b>P3</b>
Input power surge protection	<b>P7</b>
<b>Output</b>	
Output contactor	<b>PE</b>
Output filter <sup>⑤⑥</sup>	<b>PF</b>
MotoRx (300–600 ft) 1000 V/μs DV/DT filter <sup>⑥</sup>	<b>PG</b>
Single overload relay <sup>⑦</sup>	<b>PH</b>
Dual overload relays <sup>⑦</sup>	<b>PI</b>

Input Options, 250–550 hp <sup>②</sup>

Description	Catalog Number Suffix
<b>480V Only</b>	
Load switch	<b>P2</b> <sup>⑧</sup>



## Technical Data and Specifications

### 9000X Enclosed Drives

Description	NEMA Type 1/IP21 or NEMA Type 12/IP54 Specification
<b>Primary Design Features</b>	
45–66 Hz input frequency	Standard
Output: AC volts maximum	Input voltage base
Output frequency range	0–320 Hz
Initial output current ( $I_H$ )	250% for 2 seconds
Overload (1 minute [ $I_H/I_L$ ])	150%/110%
Enclosure space heater	Optional
Oversize enclosure	Standard
Output contactor	Optional
Bypass motor starter	Optional
Listings	UL, cUL
<b>Protection Features</b>	
Incoming line fuses	Optional
AC input circuit disconnect	Optional
Line reactors	Standard
Phase rotation insensitive	Standard
EMI filter	Standard
Input phase loss protection	Standard
Input overvoltage protection	Standard
Line surge protection	Standard
Output short circuit protection	Standard
Output ground fault protection	Standard
Output phase protection	Standard
Overtemperature protection	Standard
DC overvoltage protection	Standard
Drive overload protection	Standard
Motor overload protection	Standard
Programmer software	Optional
Local/remote keypad	Standard
Keypad lockout	Standard
Fault alarm output	Standard
Built-in diagnostics	Standard

Description	NEMA Type 1/IP21 or NEMA Type 12/IP54 Specification
<b>Input/Output Interface Features</b>	
Setup adjustment provisions	
Remote keypad/display	Standard
Personal computer	Standard
Operator control provisions	
Drive mounted keypad/display	Standard
Remote keypad/display	Standard
Conventional control elements	Standard
Serial communications	Optional
115 Vac control circuit	Optional
Speed setting inputs	
Keypad	Standard
0–10 Vdc potentiometer/voltage signal	Standard
4–20 mA Isolated	Configurable
4–20 mA Differential	Configurable
3–15 psig	Optional
Analog outputs	
Speed/frequency	Standard
Torque/load/current	Programmable
Motor voltage	Programmable
Kilowatts	Programmable
0–10 Vdc signals	Configurable w/jumpers
4–20 mA DC signals	Standard
Isolated signals	Optional
Discrete outputs	
Fault alarm	Standard
Drive running	Standard
Drive at set speed	Programmable
Optional parameters	14
Dry contacts	1 (2 relays Form C)
Open collector outputs	1
Additional discrete outputs	Optional
Communications	
RS-232	Standard
RS-422/485	Optional
DeviceNet™	Optional
Modbus RTU	Optional
CanOpen (slave)	Optional
Profibus-DP	Optional
Lonworks®	Optional
Johnson Controls Metasys™ N2	Optional

#### 9000X Enclosed Drives, continued

Description	NEMA Type 1/IP21 or NEMA Type 12/IP54 Specification
<b>Performance Features</b>	
Sensorless vector control	Standard
Volts/hertz control	Standard
IR and slip compensation	Standard
Electronic reversing	Standard
Dynamic braking	Optional ①
DC braking	Standard
PID setpoint controller	Programmable
Critical speed lockout	Standard
Current (torque) limit	Standard
Adjustable acceleration/deceleration	Standard
Linear or S curve accel/decel	Standard
Jog at preset speed	Standard
Thread/preset speeds	7
Automatic restart	Selectable
Coasting motor start	Standard
Coast or ramp stop selection	Standard
Elapsed time meter	Optional
Carrier frequency adjustment	1–16 kHz
<b>Standard Conditions for Application and Service</b>	
Operating ambient temperature	0 to 40°C
Storage temperature	–40 to 60°C
Humidity (maximum, non-condensing)	95%
Altitude (maximum without derate)	3300 ft (1000m)
Line voltage variation	+10/–15%
Line frequency variation	45–66 Hz
Efficiency	>96%
Power factor (displacement)	>0.94

#### Wiring Diagram

##### Power Diagram for Bypass Options RB and RA

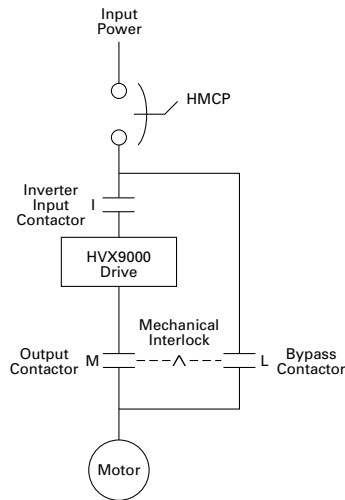

**Note**

① Some horsepower units include dynamic braking chopper as standard—refer to individual drive sections.

#### Standard I/O Specifications

Description	Specification
Six–digital input programmable	24V: “0” ≤10V, “1” ≥18V, R <sub>i</sub> >5 kohms
Two–analog input configurable w/jumpers	Voltage: 0–±10V, R <sub>i</sub> >200 kohms Current: 0 (4)–20 mA, R <sub>i</sub> = 250 ohms
Two–digital output programmable	Form C relays 250 Vac 30 Vdc 2 amp resistive
One–analog output programmable configurable w/jumper	0–20 mA, R <sub>L</sub> max. 500 ohms 10 bits ±2%
One digital output programmable	Open collector 48 Vdc 50 mA

#### I/O Specifications for Control/Communication Options

Description	Specification
Analog voltage, input	0–±10V, R <sub>i</sub> ≥200 kohms
Analog current, input	0 (4)–20 mA, R <sub>i</sub> = 250 ohms
Digital input	24V: “0” ≤10V, “1” ≥18V, R <sub>i</sub> >5 kohms
Auxiliary voltage	24V (±20%), max. 50 mA
Reference voltage	10V ±3%, max. 10 mA
Analog current, output	0 (4)–20 mA, R <sub>L</sub> = 500 kohms resolution 10 bit, accuracy ≤±2%
Analog voltage, output	0 (2)–10V, R <sub>L</sub> ≥1 kohms, resolution 10 bit, accuracy ≤±2%
<b>Relay output</b>	
Maximum switching voltage	300 Vdc, 250 Vac
Maximum switching load	8A/24 Vdc, 0.4A/300 Vdc, 2 kVA/250 Vac
Maximum continuous load	2A rms
Thermistor input	R <sub>trip</sub> = 4.7 kohms
Encoder input	24V: “0” ≤10V, “1” ≥18V, R <sub>i</sub> = 2.2 kohms 5V: “0” ≤2V, “1” ≥3V, R <sub>i</sub> = 330 ohms

**Dimensions**

Approximate Dimensions in Inches (mm)

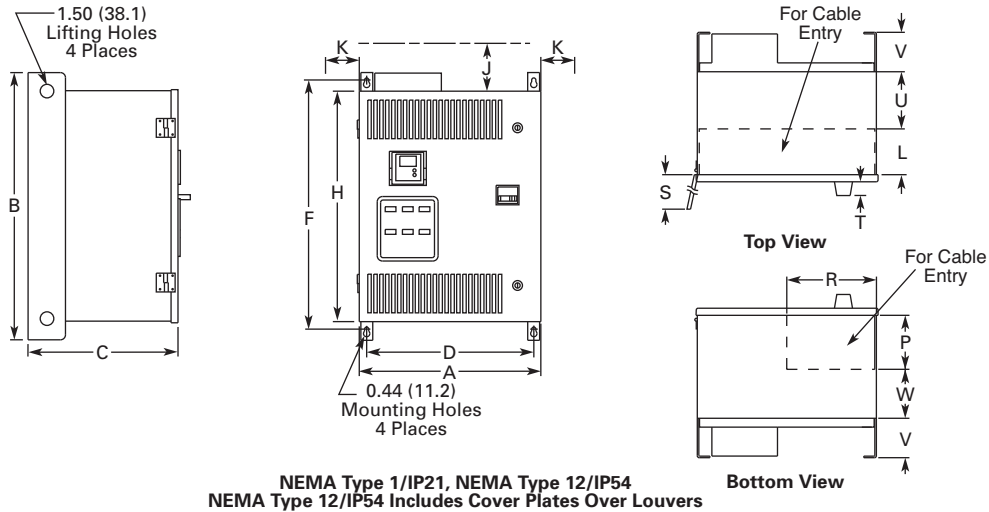
**9000X Enclosed Drives****Size 0**

For reference only, dimensions are subject to change.

Wide A	High B	Deep C	Mounting D D1		E	E1	F	G	G1	Door Height H	Min. Air Space J K	
19.9 (504)	29.0 (737)	16.4 (416)	18.3 (465)	—	—	—	27.4 (695)	—	—	25.4 (644)	4.0 (102)	3.0 (76)
Cable Entry L	M	N	P	R	Door Clearance S		CB Handle T U		V	W	Max. Approx. Shipping Weight Lbs (kg)	
5.0 (127)	—	—	6.0 (152)	9.6 (245)	26.4 (669)		1.5 (38) 6.3 (160)		4.3 (108)	5.3 (134)	200 (91)	

# 36.3

## Adjustable Frequency Drives

### SVX9000 Drives

Approximate Dimensions in Inches (mm)

#### Size 1

36

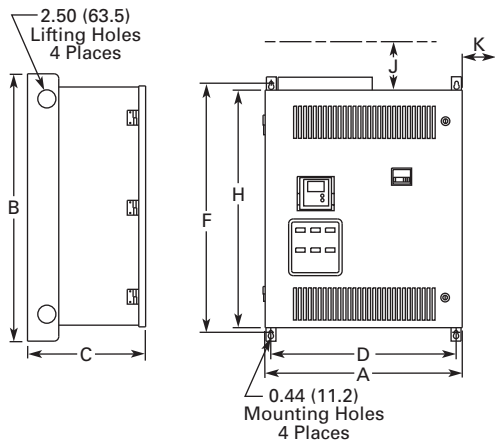

**NEMA Type 1/IP21, NEMA Type 12/IP54**  
**NEMA Type 12/IP54 Includes Cover Plates Over Louvers**

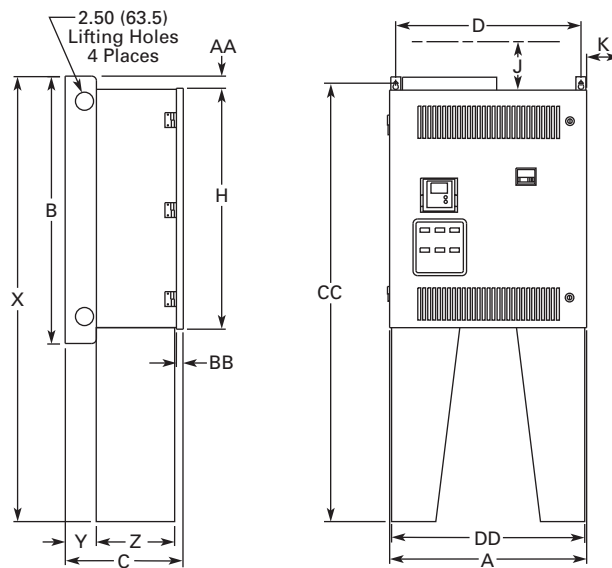

**NEMA Type 1/IP21, NEMA Type 12/IP54**  
**with Floor Stand**

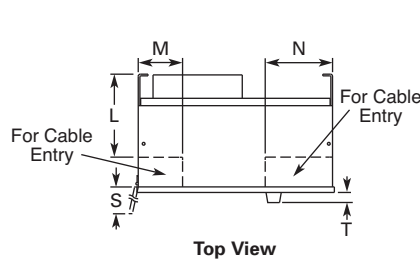

**Top View**

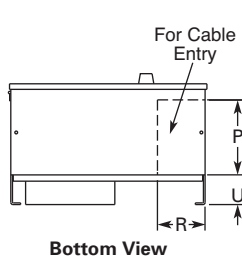

**Bottom View**

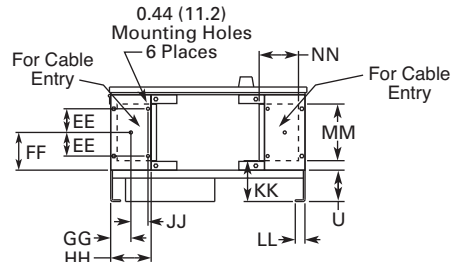

**Bottom View**  
**NEMA Type 1/IP21, NEMA Type 12/IP54**  
**with Floor Stand**

For reference only, dimensions are subject to change.

Wide A	High B	Deep C	Mounting D	D1	E	E1	F	G	G1	Door Height H	Min. Air Space J K	
26.4 (669)	36 (914)	16.3 (414)	24.8 (630)	—	—	—	34.0 (864)	—	—	32.4 (822)	4.0 (102)	3.0 (76)

Cable Entry L	M	N	P	R	Door Clearance S	CB Handle T	U	V	W	Max. Approx. Shipping Weight Lbs (kg)
11.0 (279)	6.0 (152)	9.0 (229)	10.0 (254)	6.5 (165)	26.4 (669)	1.5 (38)	4.3 (108)	—	—	230 (104)

#### Floor Stand

X	Y	Z	AA	BB	CC	DD	EE	FF	GG	HH	JJ	KK	LL	MM	NN	PP	RR	SS	TT	UU	VV
56.0 (1422)	4.3 (108)	11.1 (281)	1.8 (46)	0.8 (19)	55.2 (1402)	26.0 (660)	3.5 (90)	5.5 (141)	3.0 (76)	6.0 (152)	2.0 (51)	5.4 (136)	1.1 (28)	8.8 (224)	5.4 (137)	—	—	—	—	—	—

Approximate Dimensions in Inches (mm)

## Size 2

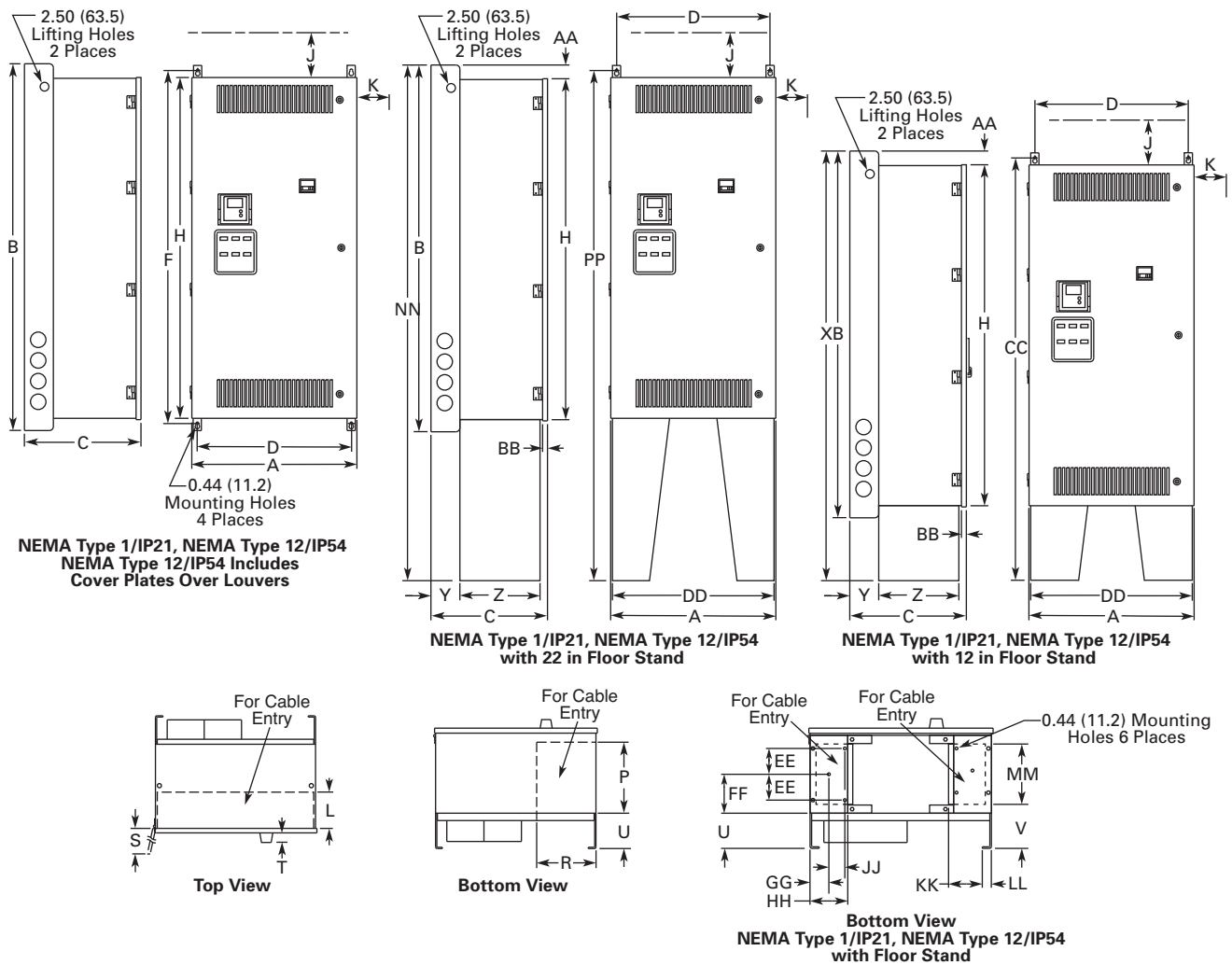

For reference only, dimensions are subject to change.

Wide	High	Deep	Mounting							Door Height	Min. Air Space	
A	B	C	D	D1	E	E1	F	G	G1	H	J	K
26.4 (669)	59.0 (1499)	19.4 (492)	24.8 (630)	—	—	—	57.0 (1448)	—	—	55.4 (1406)	4.0 (102)	3.0 (76)

Cable Entry					Door Clearance	CB Handle						Max. Approx. Shipping Weight	
L	M	N	P	R	S	T	U	V	W	XX	YY	ZZ	Lbs (kg)
5.9 (149)	—	—	12.4 (315)	9.5 (241)	26.4 (669)	1.5 (38)	4.8 (121)	5.9 (151)	—	—	—	—	380 (173)

Floor Stand																					
X	Y	Z	AA	BB	CC	DD	EE	FF	GG	HH	JJ	KK	LL	MM	NN	PP	RR	SS	TT	UU	VV
69.0 (1753)	4.8 (121)	13.6 (344)	1.8 (46)	0.8 (19)	68.2 (1732)	26.0 (660)	4.8 (121)	6.8 (172)	3.0 (76)	6.0 (152)	2.0 (51)	5.0 (127)	1.1 (28)	11.3 (288)	79.0 (2007)	78.2 (1986)	—	—	—	—	

# 36.3

## Adjustable Frequency Drives

### SVX9000 Drives

Approximate Dimensions in Inches (mm)

#### Size 3

36

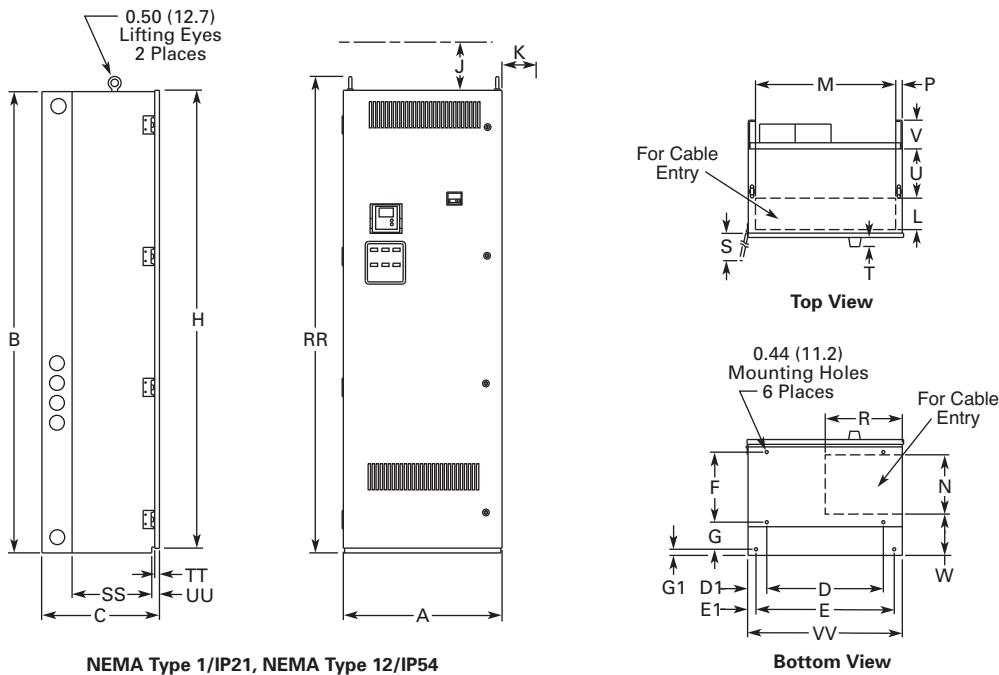

For reference only, dimensions are subject to change.

Wide A	High B	Deep C	Mounting D D1		E	E1	F	G	G1	Door Height H	Min. Air Space J K	
26.4 (671)	77.0 (1956)	19.4 (493)	19.5 (495)	3.3 (83)	23.0 (584)	1.5 (38)	11.7 (298)	5.5 (140)	0.9 (24)	76.4 (1939)	4.0 (102)	3.0 (76)

Cable Entry L M		N	P	R	Door Clearance S	CB Handle T U		V	W	RR	SS	TT	UU	VV	Max. Approx. Shipping Weight Lbs (kg)
5.3 (133)	23.4 (594)	10.0 (254)	1.3 (32)	12.9 (328)	26.4 (669)	1.5 (38)	8.0 (203)	4.8 (121)	6.8 (173)	79.5 (2018)	13.40 (340)	0.8 (19)	1.3 (32)	26.0 (660)	690 (313)

Approximate Dimensions in Inches (mm)

## Size 4

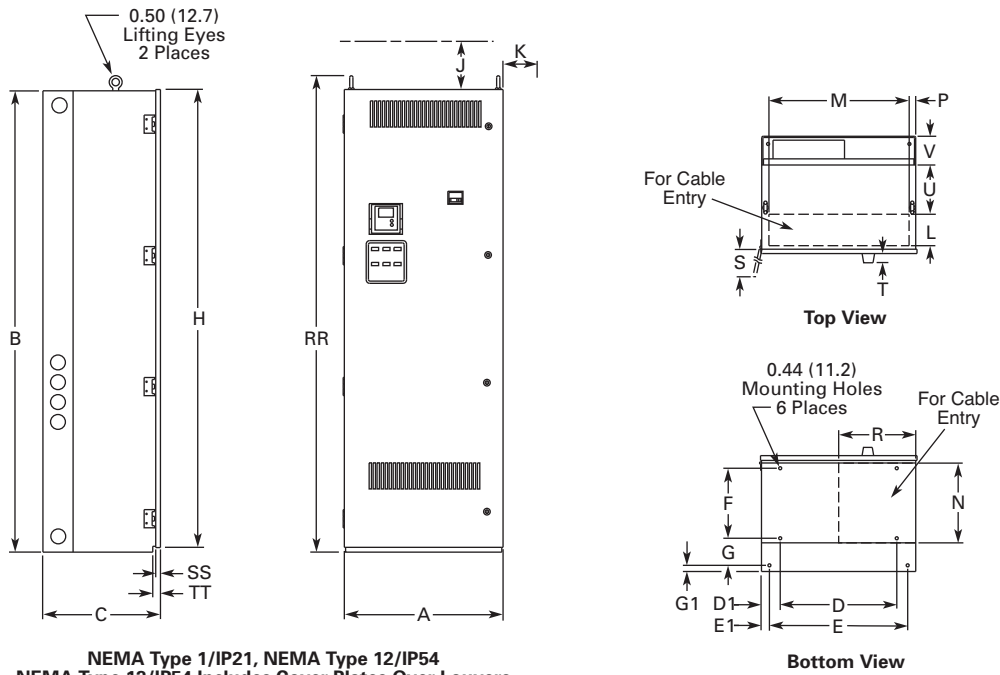

For reference only, dimensions are subject to change.

Wide	High	Deep	Mounting								Door Height	Min. Air Space	
A	B	C	D	D1	E	E1	F	G	G1	H	J	K	
26.4 (671)	90.0 (2286)	19.4 (493)	19.5 (495)	3.3 (83)	23.0 (584)	1.5 (38)	11.7 (298)	5.5 (140)	0.9 (24)	89.4 (2270)	4.0 (102)	3.0 (76)	

Cable Entry		Door Clearance		CB Handle										Max. Approx. Shipping Weight	
L	M	N	P	R	S	T	U	V	W	RR	SS	TT	UU	VV	Lbs (kg)
5.3 (133)	23.4 (594)	13.8 (351)	1.0 (25)	11.2 (286)	26.4 (669)	1.5 (38)	8.0 (204)	4.8 (121)	—	92.5 (2349)	0.8 (19)	1.3 (32)	—	—	825 (375)

# 36.3

## Adjustable Frequency Drives

### SVX9000 Drives

Approximate Dimensions in Inches (mm)

#### Size 5

36

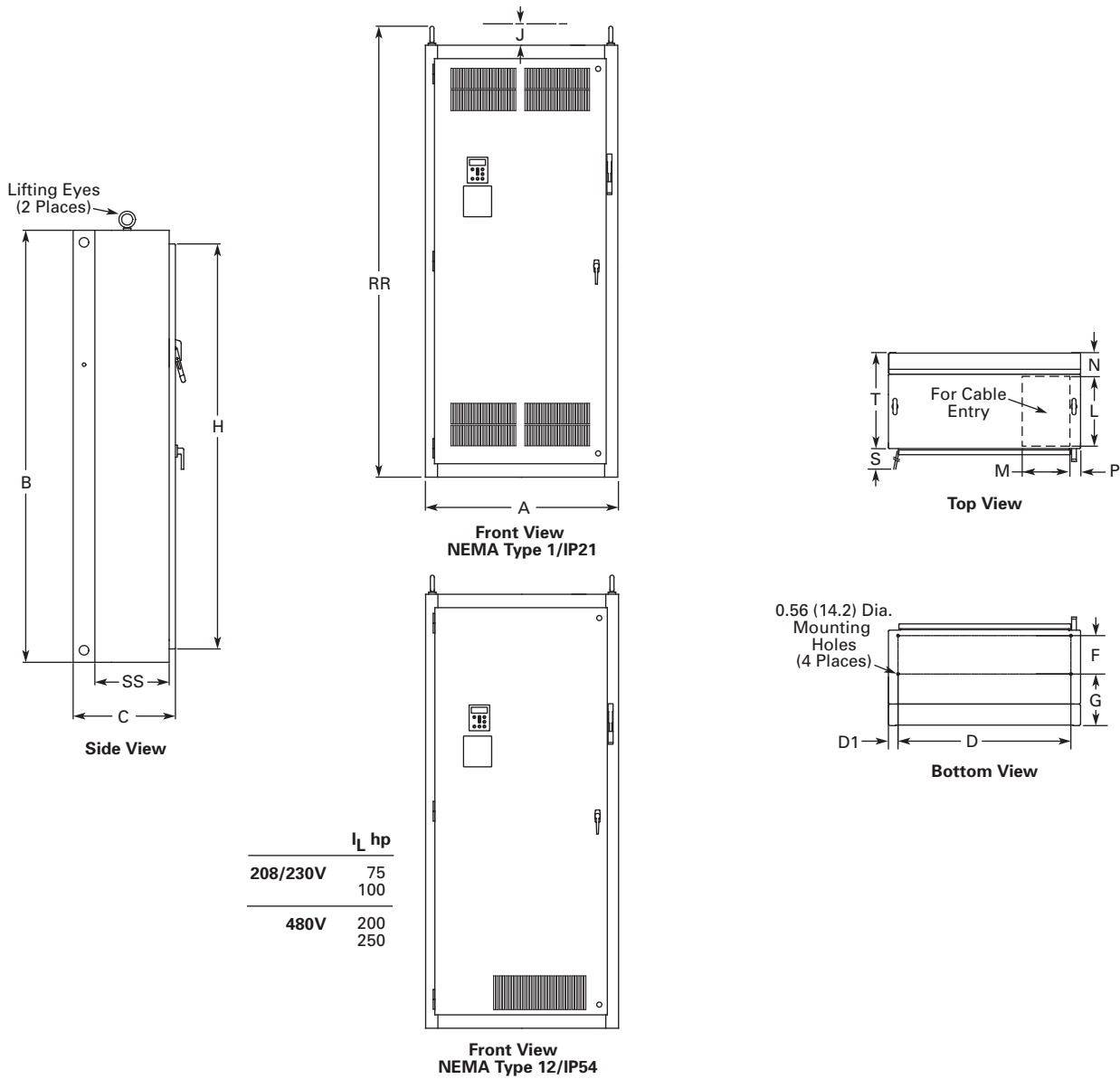

For reference only, dimensions are subject to change.

Wide	High	Deep	Mounting							Door Height	Min. Air Space	
A	B	C	D	D1	E	E1	F	G	G1	H	J	K
40.0 (1016)	90.0 (2286)	21.3 (541)	36.0 (914)	2.0 (51)	—	—	8.0 (203)	10.8 (273)	—	84.4 (2143)	4.0 (102)	—

Cable Entry			Door Clearance											Max. Approx. Shipping Weight	
L	M	N	P	R	S	T	U	V	W	RR	SS	TT	UU	VV	Lbs (kg)
15.0 (381)	10.0 (254)	4.8 (122)	2.0 (51)	—	36.3 (921)	20.0 (508)	—	—	—	94.0 (2387)	15.5 (394)	—	—	—	1275 (579)



Approximate Dimensions in Inches (mm)

## Size 5-1P

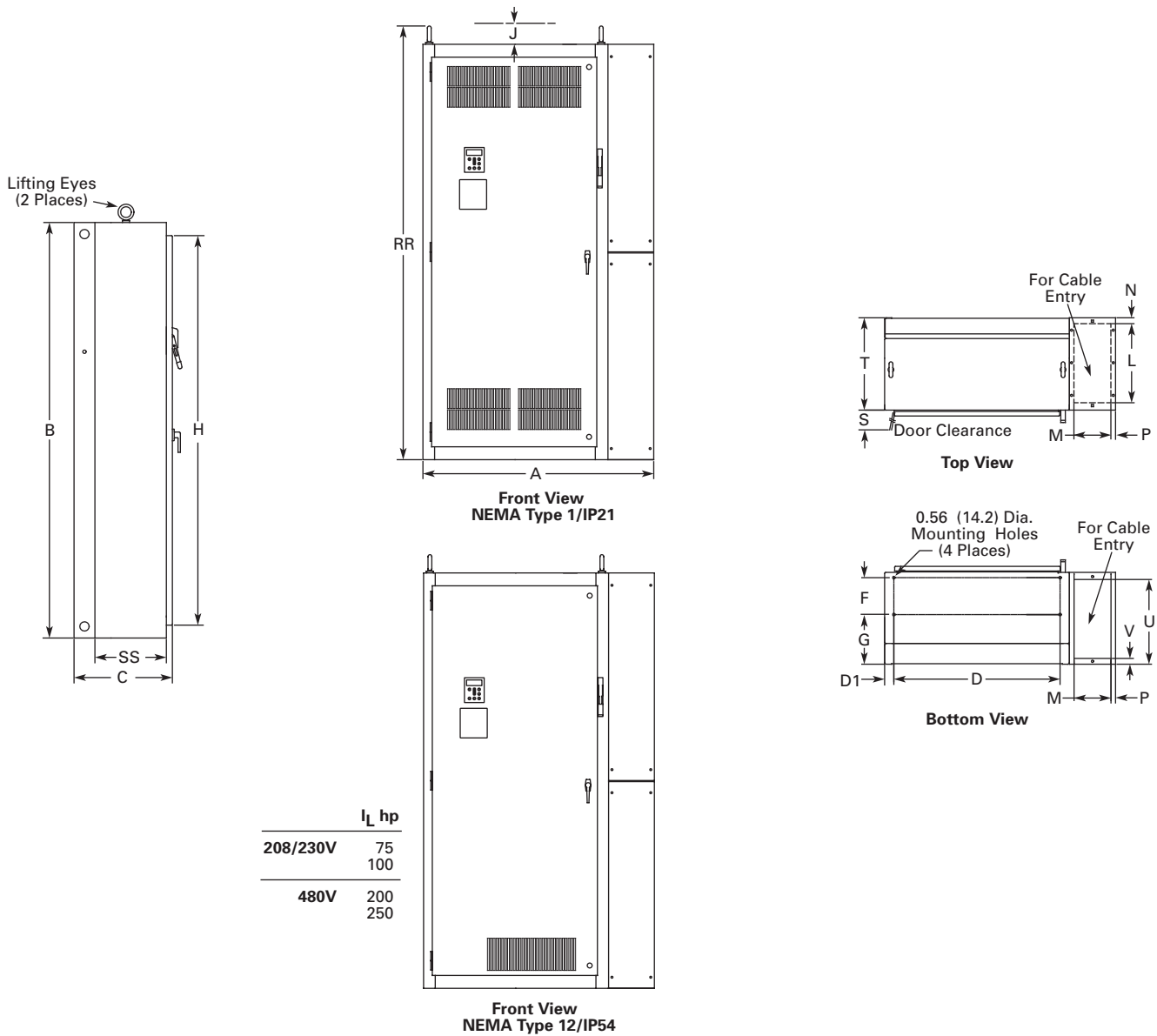

For reference only, dimensions are subject to change.

Wide	High	Deep	Mounting							Door Height	Min. Air Space	
A	B	C	D	D1	E	E1	F	G	G1	H	J	K
50.0 (1270)	90.0 (2286)	21.3 (541)	36.0 (914)	2.0 (51)	—	—	8.0 (203)	10.8 (273)	—	84.4 (2143)	4.0 (102)	—

Cable Entry			Door Clearance										Max. Approx. Shipping Weight		
L	M	N	P	R	S	T	U	V	W	RR	SS	TT	UU	VV	Lbs (kg)
17.1 (435)	8.0 (203)	1.3 (33)	1.0 (25)	—	36.3 (921)	20.0 (508)	18.4 (466)	1.3 (32)	—	94.0 (2387)	15.5 (394)	—	—	—	1375 (624)

# 36.3

## Adjustable Frequency Drives

SVX9000 Drives

Approximate Dimensions in Inches (mm)

### Size 5-2P

36

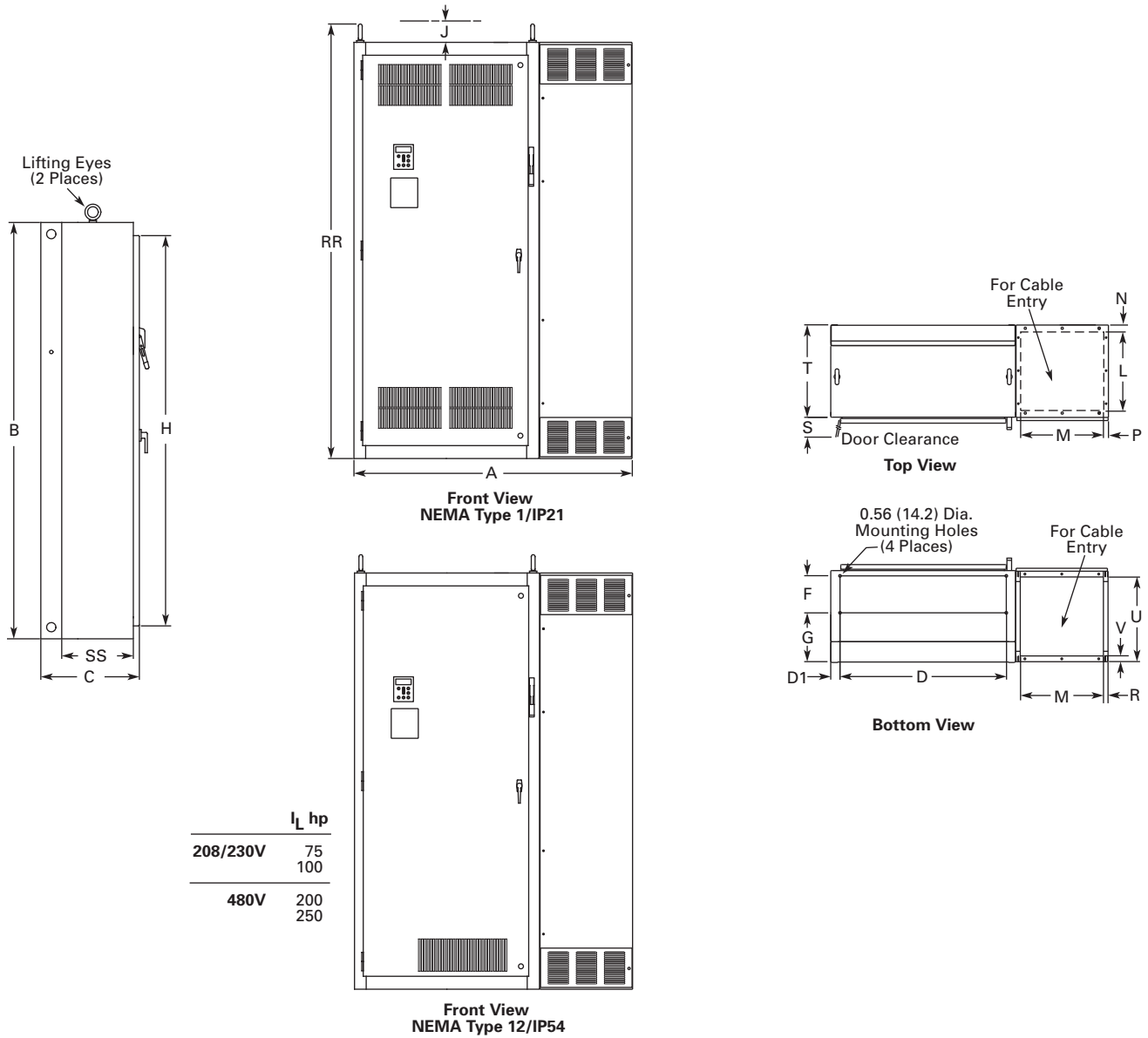

For reference only, dimensions are subject to change.

Wide	High	Deep	Mounting							Door Height	Min. Air Space				
A	B	C	D	D1	E	E1	F	G	G1	H	J	K			
<b>Enclosure Size 5-2P</b>															
60.0 (1524)	90.0 (2286)	21.3 (541)	36.0 (914)	2.0 (51)	—	—	8.0 (203)	10.8 (273)	—	84.4 (2143)	4.0 (102)	—			
Cable Entry		Door Clearance										Max. Approx. Shipping Weight			
L	M	N	P	R	S	T	U	V	W	RR	SS	TT	UU	VV	Lbs (kg)
17.0 (432)	18.0 (457)	1.5 (38)	1.0 (25)	0.9 (23)	36.3 (921)	20.0 (508)	18.4 (466)	1.3 (32)	—	94.0 (2387)	15.5 (394)	—	—	—	1585 (720)

Approximate Dimensions in Inches (mm)

### Size 6

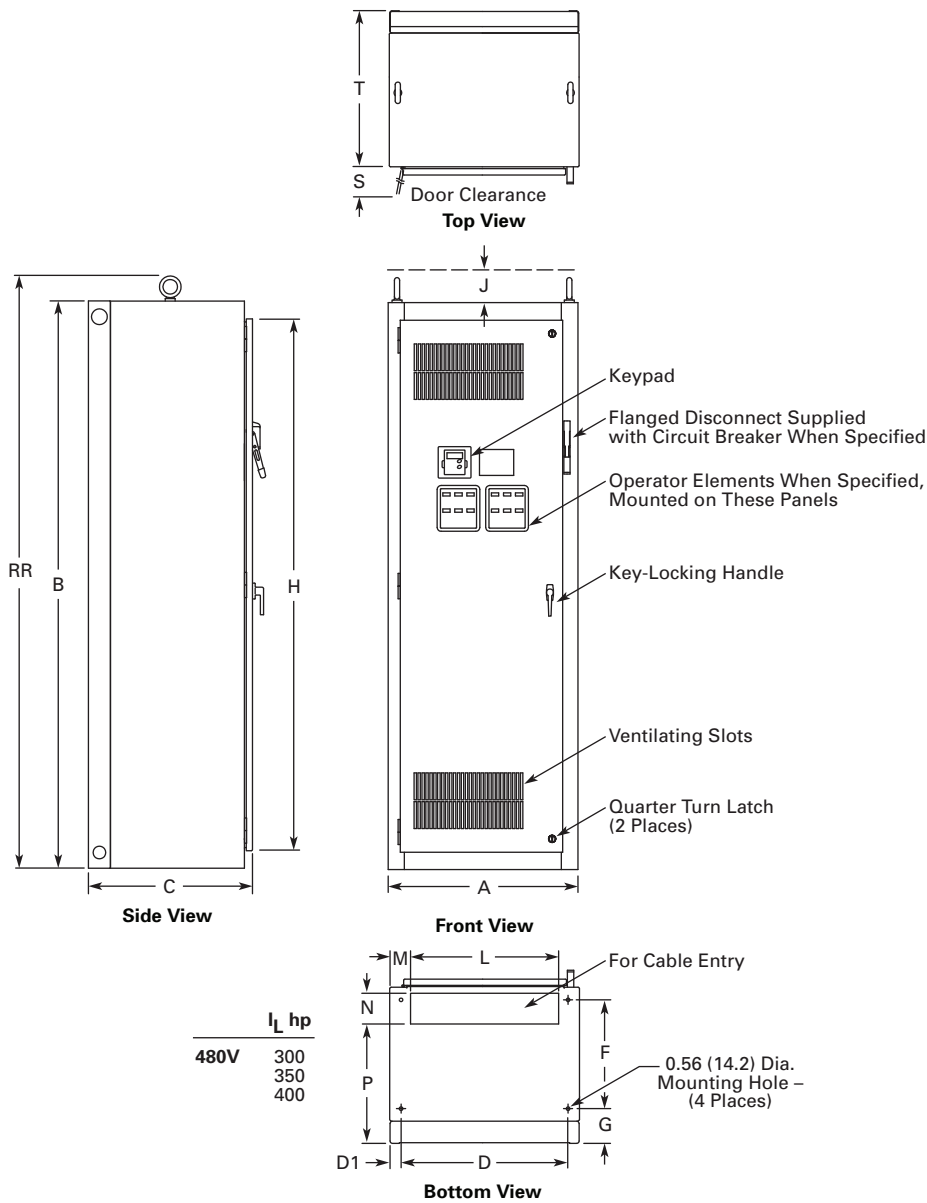

For reference only, dimensions are subject to change. See **Page V6-T36-57**, notes 3 and 5 for enclosure and option selection.

Wide A	High B	Deep C	Mounting							Door Height H	Min. Air Space	
A	B	C	D	D1	E	E1	F	G	G1	H	J	K
30.0 (762)	90.0 (2286)	26.0 (660)	26.5 (673)	1.8 (46)	—	—	17.3 (438)	5.5 (140)	—	84.4 (2143)	4.0 (102)	—

Cable Entry			Door Clearance										Max. Approx. Shipping Weight		
L	M	N	P	R	S	T	U	V	W	RR	SS	TT	UU	VV	Lbs (kg)
23.5 (597)	3.3 (84)	4.5 (114)	19.3 (490)	—	26.2 (667)	24.8 (629)	—	—	—	93.9 (2386)	—	—	—	—	1500 (681)

# 36.3

## Adjustable Frequency Drives

### SVX9000 Drives

Approximate Dimensions in Inches (mm)

#### Size 8

36

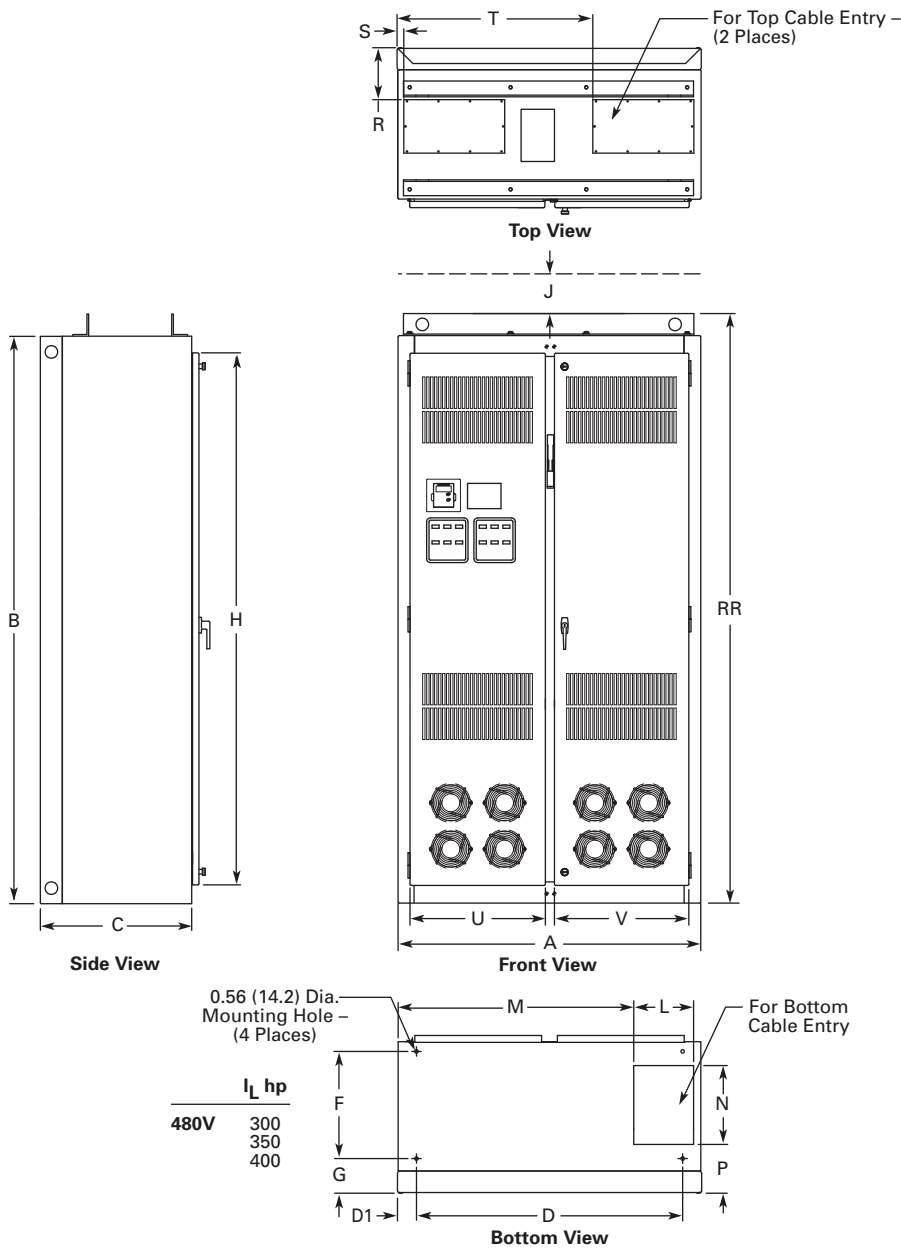

For reference only, dimensions are subject to change. See **Page V6-T36-57**, notes 3 and 5 for enclosure and option selection.

Wide A	High B	Deep C	Mounting		E	E1	F	G	G1	Door Height H	Min. Air Space J	K
48.0 (1219)	90.0 (2286)	24.0 (610)	42.2 (1072)	3.0 (77)	—	—	—	5.5 (139)	—	84.4 (2143)	4.0 (102)	—

Cable Entry											Max. Approx. Shipping Weight Lbs (kg)					
L	M	N	P	R	S	T	U	V	W	RR	SS	TT	UU	VV		
9.5 (241)	37.5 (952)	12.5 (318)	7.7 (196)	8.3 (210)	1.3 (32)	31.0 (787)	21.5 (545)	21.3 (541)	—	93.5 (2375)	—	—	—	—	2000	(908)

Approximate Dimensions in Inches (mm)

### Size 9

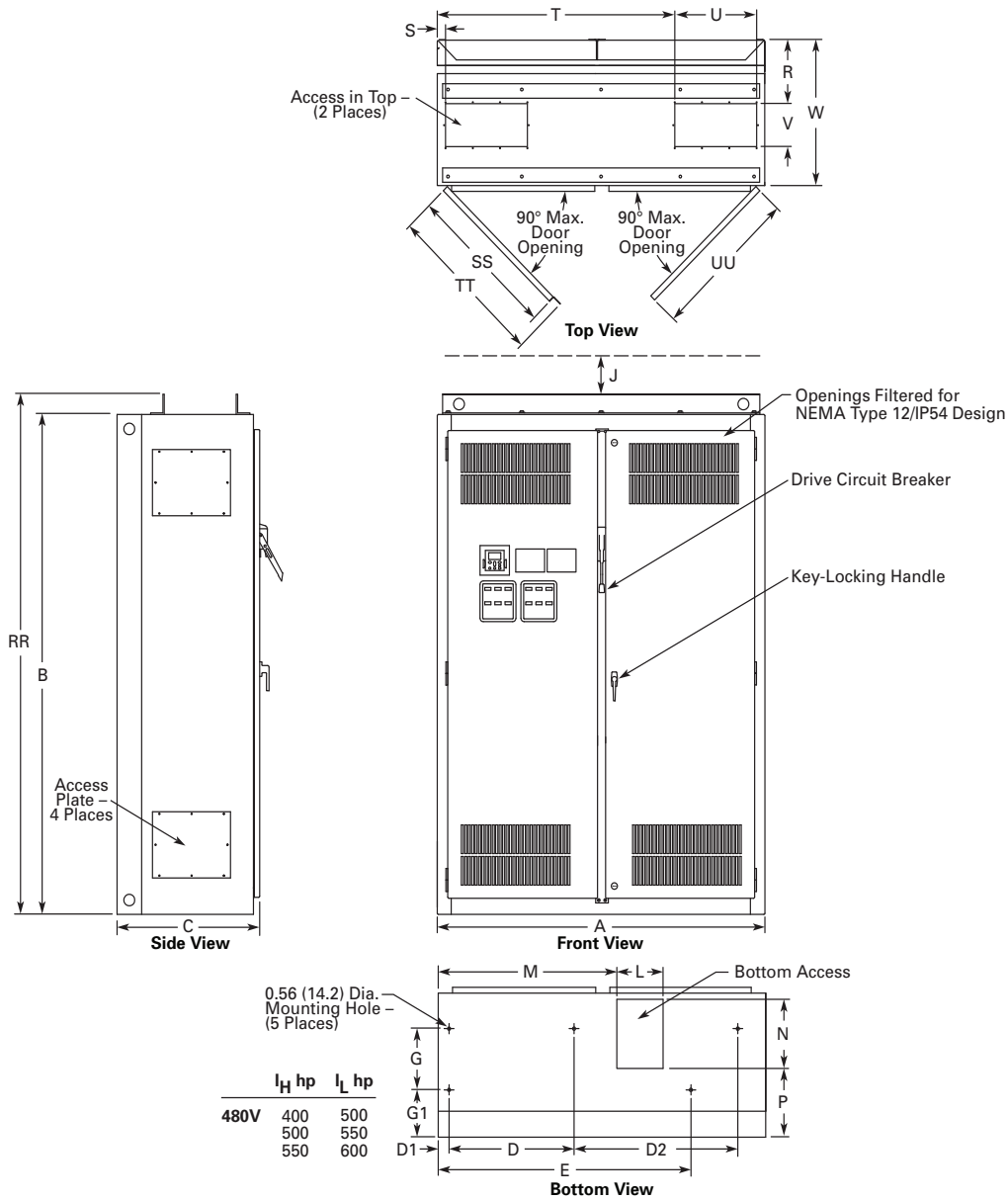

For reference only, dimensions are subject to change. See **Page V6-T36-57**, notes 3 and 5 for enclosure and option selection.

Wide	High	Deep	Mounting		Door Height		Min. Air Space					
A	B	C	D	D1	E	E1	F	G	G1	H	J	K
60.0 (1524)	90.0 (2286)	260.1 (664)	22.9 (582)	2.0 (51)	30.0 (762)	44.3 (1125)	10.6 (270)	10.6 (270)	8.2 (208)	—	4.0 (102)	—

Cable Entry														Max. Approx. Shipping Weight Lbs (kg)	
L	M	N	P	R	S	T	U	V	W	RR	SS	TT	UU		VV
8.5 (216)	32.7 (831)	12.0 (305)	11.9 (303)	9.8 (249)	1.5 (38)	43.5 (1105)	15.0 (381)	7.5 (191)	25.0 (635)	93.5 (2375)	27.4 (696)	290.1 (738)	270.1 (687)	—	2500 (1135)

SVX9000 VFD Pump Panels



### SVX9000 VFD Pump Panels

#### Product Description

- **Standard Enclosed**—covers a wide range of the most commonly ordered options. Pre-engineering eliminates the lead time normally associated with customer specific options.
- **Modified Standard Enclosed**—applies to specific customer requirements that vary from the Standard Enclosed offering, such as the need for an additional indicating light or minor modifications to drawings. *Consult your Eaton representative for assistance in pricing and lead time.*
- **Custom Engineered**—for those applications with more unique or complex requirements, these are individually engineered to the customer's needs. *Consult your Eaton representative for assistance in pricing and lead time.*

#### Features

- NEMA Type 12/IP54 or NEMA Type 3R enclosures
- Input voltage: 208V, 230V, 480V and 575V (consult factory)
- Complete range of control, network and power options
- Horsepower range:
  - 208V—3/4 to 100 hp I<sub>H</sub>; 1 to 100 hp I<sub>L</sub>
  - 230V—3/4 to 100 hp I<sub>H</sub>; 1 to 100 hp I<sub>L</sub>
  - 480V—1 to 350 hp I<sub>H</sub>; 1-1/2 to 400 hp I<sub>L</sub>
- HMCP padlockable
- Single-phase input available—consult factory

#### Standards and Certifications

- UL Listed
- cUL Listed



### Contents

#### Description

Description	Page
SVX9000 Open Drives .....	V6-T36-17
SVX9000 Enclosed Drives .....	V6-T36-52
SVX9000 VFD Pump Panels	
Catalog Number Selection .....	V6-T36-79
Product Selection .....	V6-T36-80
Options .....	V6-T36-85
Technical Data and Specifications .....	V6-T36-89
Wiring Diagrams .....	V6-T36-91
Dimensions .....	V6-T36-92

#### Product Identification

##### SVX9000 Pump Application

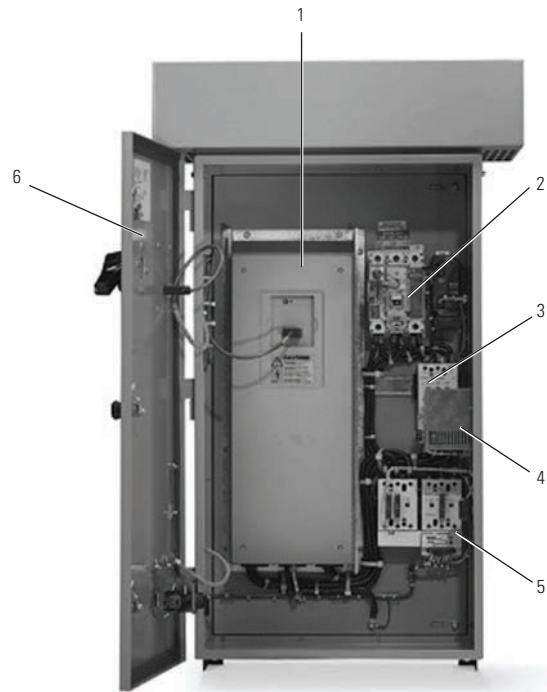

- |  |   |
|--|---|
| 1 SVX9000 variable frequency drive                             | 4 Space heater<br>Option S9                     |
| 2 Input disconnect (HMCP)<br>Option P1                         | 5 Bypass contactor<br>Option RA/RB              |
| 3 Input contactor (included as<br>standard with bypass option) | 6 Door-mounted keypad<br>(included as standard) |

## Catalog Number Selection

## SVX9000 Enclosed NEMA Type 12/IP54/3R Drive

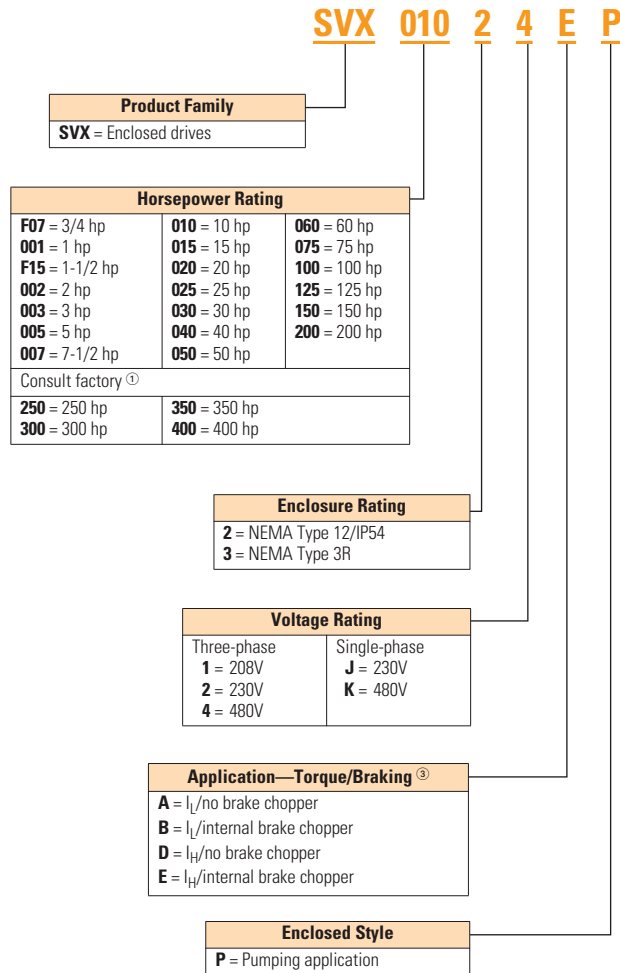

Enclosed Options <sup>②⑤⑥</sup>		Type
<b>K1</b>	Door-mounted speed potentiometer <sup>④</sup>	Control
<b>K2</b>	Door-mounted speed potentiometer with HOA selector switch <sup>④</sup>	Control
<b>K5</b>	MANUAL/AUTO reference switch (22 mm)	Control
<b>K6</b>	START and STOP pushbuttons (22 mm)	Control
<b>K9</b>	(2) Factory installed auxiliary contacts	Power
<b>L1</b>	Power on and fault pilot lights	Light
<b>L2</b>	Bypass pilot lights for RA bypass option <sup>⑧</sup>	Addl. bypass
<b>LD</b>	Green STOP light	Light
<b>LE</b>	Red RUN light	Light
<b>LU</b>	Light (22 mm)	Light
<b>LW</b>	PTT light (22 mm)	Light
<b>LY</b>	Adder for LED each	Light
<b>P1</b>	Input disconnect (HMCP) 100 kAIC	Input
<b>P3</b>	Input line fuses (200 kAIC)	Input
<b>P7</b>	Input power surge protection	Input
<b>P8</b>	TVSS transient voltage surge suppressor	Input
<b>PE</b>	Output contactor	Output
<b>RA</b>	Manual HOA bypass controller <sup>⑧</sup>	Bypass
<b>S5</b>	Floor stand 22 in	Enclosure
<b>S9</b>	Space heater w/out CPT	Enclosure
<b>SA</b>	Space heater w/CPT	Enclosure
<b>SB</b>	Socket type control relay	Enclosure
<b>SE</b>	On-delay timer	Enclosure
<b>SF</b>	Off-delay timer	Enclosure

Communication Options <sup>⑦</sup>	
<b>C2</b>	Modbus
<b>C3</b>	Profibus DP
<b>C4</b>	LonWorks
<b>C5</b>	Profibus DP (D9 connector)
<b>C6</b>	CanOpen (slave)
<b>C7</b>	DeviceNet
<b>C8</b>	Modbus (D9 type connector)
<b>CA</b>	Johnson Controls N2
<b>CI</b>	Modbus TCP
<b>CJ</b>	BACnet
<b>CK</b>	Ethernet IP
<b>D3</b>	RS-232 with D9 connection

Control Options	
<b>B1</b>	= 6 DI, 1 ext +24 Vdc/EXT +24 Vdc
<b>B2</b>	= 1 RO (NC-NO), 1 RO (NO), 1 therm
<b>B4</b>	= 1 AI (mA isolated), 2 AO (mA isolated), 1 ext +24 Vdc/EXT +24 Vdc
<b>B5</b>	= 3 RO (NO)
<b>B8</b>	= 1 ext +24 Vdc/EXT +24 Vdc, 3 Pt100
<b>B9</b>	= 1 RO (NO), 5 DI 42–240 Vac input

## Notes

- ① Consult factory.
- ② Local/remote keypad is included as the standard control panel.
- ③ Brake chopper is a factory installed option only, see drive options on **Page V6-T36-18**. External dynamic braking resistors not included. Consult factory.
- ④ Includes local/remote speed reference switch.
- ⑤ Some options are voltage and/or horsepower specific. Consult your Eaton representative for details.
- ⑥ See **Page V6-T36-87** for descriptions.
- ⑦ See **Pages V6-T36-85** and **V6-T36-86** for complete descriptions.
- ⑧ Bypass options applicable only in the pump panel three-phase design.

#### Product Selection

##### When Ordering

- Select a base catalog number that meets the application requirements—nominal horsepower, voltage and enclosure rating (the enclosed drive's continuous output amp rating should be equal to or

greater than the motor's full load amp rating). The base enclosed package includes a standard drive, door mounted local/remote keypad and enclosure.

- If dynamic brake chopper or control/communication option is desired, change the appropriate code in the base catalog number.

- Select enclosed options. Add the codes as suffixes to the base catalog number in alphabetical and numeric order.
- **Read all footnotes.**

#### 208V Drives

##### SVX9000 Enclosed Drives



#### Pump Panel Style (Three-Phase)

Enclosure Size ①	hp	NEMA Type 12/IP54		NEMA Type 3R	
		Frame Size	Base Catalog Number ②	Frame Size	Base Catalog Number ②
<b>High Overload Drive and Enclosure</b>					
A	3/4	4	SVXF0721EP	4	SVXF0731EP
	1		SVX00121EP		SVX00131EP
	1-1/2		SVXF1521EP		SVXF1531EP
	2		SVX00221EP		SVX00231EP
	3	5	SVX00321EP		SVX00331EP
	5		SVX00521EP		SVX00531EP
	7-1/2		SVX00721EP		SVX00731EP
10	6	SVX01021EP	SVX01031EP		
15		SVX01521EP	SVX01531EP		
B	20	7	SVX02021DP	7	SVX02031DP
	25		SVX02521DP		SVX02531DP
	30		SVX03021DP		SVX03031DP
C	40	8	SVX04021DP	8	SVX04031DP
	50		SVX05021DP		SVX05031DP
	60		SVX06021DP		SVX06031DP
D	75	9	SVX07521DP	9	SVX07531DP
	100		SVX10021DP		SVX10031DP
	<b>Low Overload Drive and Enclosure</b>				
A	1	4	SVX00121BP	4	SVX00131BP
	1-1/2		SVXF1521BP		SVXF1531BP
	2		SVX00221BP		SVX00231BP
	3		SVX00321BP		SVX00331BP
	5	5	SVX00521BP		SVX00531BP
	7-1/2		SVX00721BP		SVX00731BP
	10		SVX01021BP		SVX01031BP
15	6	SVX01521BP	SVX01531BP		
20		SVX02021BP	SVX02031BP		
B	25	7	SVX02521AP	7	SVX02531AP
	30		SVX03021AP		SVX03031AP
	40		SVX04021AP		SVX04031AP
C	50	8	SVX05021AP	8	SVX05031AP
	60		SVX06021AP		SVX06031AP
	75		SVX07521AP		SVX07531AP
D	100	9	SVX10021AP	9	SVX10031AP

##### Notes

- ① Enclosure dimensions starting on [Page V6-T36-92](#).
- ② Includes drive, local/remote keypad and enclosure.



## 230V Drives

## SVX9000 Enclosed Drives



## Pump Panel Style (Three-Phase)

Enclosure Size ①	hp	NEMA Type 12/IP54		NEMA Type 3R	
		Frame Size	Base Catalog Number ②	Frame Size	Base Catalog Number ②
<b>High Overload Drive and Enclosure</b>					
A	3/4	4	SVXF0722EP	4	SVXF0732EP
	1		SVX00122EP		SVX00132EP
	1-1/2		SVXF1522EP		SVXF1532EP
	2	SVX00222EP	SVX00232EP		
	3	5	SVX00322EP	5	SVX00332EP
	5		SVX00522EP		SVX00532EP
	7-1/2		SVX00722EP		SVX00732EP
10	6	SVX01022EP	6	SVX01032EP	
		SVX01522EP		SVX01532EP	
B	15	7	SVX02022DP	7	SVX02032DP
	20		SVX02522DP		SVX02532DP
	25		SVX03022DP		SVX03032DP
C	30	8	SVX04022DP	8	SVX04032DP
	40		SVX05022DP		SVX05032DP
	50		SVX06022DP		SVX06032DP
D	60	9	SVX07522DP	9	SVX07532DP
	75		SVX10022DP		SVX10032DP
	100				
<b>Low Overload Drive and Enclosure</b>					
A	1	4	SVX00122BP	4	SVX00132BP
	1-1/2		SVXF1522BP		SVXF1532BP
	2		SVX00222BP		SVX00232BP
	3	SVX00322BP	SVX00332BP		
	5	5	SVX00522BP	5	SVX00532BP
	7-1/2		SVX00722BP		SVX00732BP
	10		SVX01022BP		SVX01032BP
15	6	SVX01522BP	6	SVX01532BP	
		SVX02022BP		SVX02032BP	
B	20	7	SVX02522AP	7	SVX02532AP
	25		SVX03022AP		SVX03032AP
	30		SVX04022AP		SVX04032AP
C	40	8	SVX05022AP	8	SVX05032AP
	50		SVX06022AP		SVX06032AP
	60		SVX07522AP		SVX07532AP
D	75	9	SVX10022AP	9	SVX10032AP
	100				

**Notes**

- ① Enclosure dimensions starting on **Page V6-T36-92**.  
 ② Includes drive, local/remote keypad and enclosure.

SVX9000 Enclosed Drives

#### Pump Panel Style (Single-Phase)

36



Enclosure Size ①	hp	NEMA Type 12/IP54		NEMA Type 3R	
		Frame Size	Base Catalog Number ②	Frame Size	Base Catalog Number ②
<b>Low Overload Drive and Enclosure</b>					
A	3/4	4	SVXF072JBP	4	SVXF073JBP
	1		SVX0012JBP		SVX0013JBP
	2	5	SVX0022JBP	5	SVX0023JBP
	3		SVX0032JBP		SVX0033JBP
	5		SVX0052JBP		SVX0053JBP
	7-1/2	6	SVX0072JBP	6	SVX0073JBP
	10		SVX0102JBP		SVX0103JBP
B	15	7	SVX0152JBP	7	SVX0153JBP
	20		SVX0202JAP		SVX0203JAP
C	25	8	SVX0252JAP	8	SVX0253JAP
	30		SVX0302JAP		SVX0303JAP
	40		SVX0402JAP		SVX0403JAP

**Notes**

- ① Enclosure dimensions starting on **Page V6-T36-92**.
- ② Includes drive, local/remote keypad and enclosure.

## 480V Drives

## SVX9000 Enclosed Drives



## Pump Panel Style (Three-Phase)

Enclosure Size ①	hp	NEMA Type 12/IP54		NEMA Type 3R	
		Frame Size	Base Catalog Number ②	Frame Size	Base Catalog Number ②
<b>High Overload Drive and Enclosure</b>					
A	1	4	SVX00124EP	4	SVX00134EP
	1-1/2		SVXF1524EP		SVXF1534EP
	2		SVX00224EP		SVX00234EP
	3		SVX00324EP		SVX00334EP
	5	5	SVX00524EP	SVX00534EP	
	7-1/2		SVX00724EP	SVX00734EP	
	10		SVX01024EP	SVX01034EP	
	15		SVX01524EP	SVX01534EP	
	20		6	SVX02024EP	SVX02034EP
	25			SVX02524EP	SVX02534EP
B	30	7	SVX03024EP	7	SVX03034EP
	40		SVX04024DP		SVX04034DP
	50		SVX05024DP		SVX05034DP
	60		SVX06024DP		SVX06034DP
C	75	8	SVX07524DP	8	SVX07534DP
	100		SVX10024DP		SVX10034DP
	125		SVX12524DP		SVX12534DP
D	150	9	SVX15024DP	9	SVX15034DP
	200		SVX20024DP		SVX20034DP
Consult factory	250	10	SVX25024DP	10	SVX25034DP
	300		SVX30024DP		SVX30034DP
	350		SVX35024DP		SVX35034DP
<b>Low Overload Drive and Enclosure</b>					
A	1-1/2	4	SVXF1524BP	4	SVXF1534BP
	2		SVX00224BP		SVX00234BP
	3		SVX00324BP		SVX00334BP
	5		SVX00524BP		SVX00534BP
	7-1/2	5	SVX00724BP	SVX00734BP	
	10		SVX01024BP	SVX01034BP	
	15		SVX01524BP	SVX01534BP	
	20		SVX02024BP	SVX02034BP	
	25		6	SVX02524BP	SVX02534BP
	30			SVX03024BP	SVX03034BP
B	40	7	SVX04024BP	7	SVX04034BP
	50		SVX05024AP		SVX05034AP
	60		SVX06024AP		SVX06034AP
	75		SVX07524AP		SVX07534AP
C	100	8	SVX10024AP	8	SVX10034AP
	125		SVX12524AP		SVX12534AP
	150		SVX15024AP		SVX15034AP
D	200	9	SVX20024AP	9	SVX20034AP
	250		SVX25024AP		SVX25034AP
Consult factory	300	10	SVX30024AP	10	SVX30034AP
	400		SVX40024AP		SVX40034AP

**Notes**

- ① Enclosure dimensions starting on Page V6-T36-92.  
 ② Includes drive, local/remote keypad and enclosure.

SVX9000 Enclosed Drives

#### Pump Panel Style (Single-Phase)

36



Enclosure Size <sup>①</sup>	hp	NEMA Type 12/IP54		NEMA Type 3R	
		Frame Size	Base Catalog Number <sup>②</sup>	Frame Size	Base Catalog Number <sup>②</sup>
<b>Low Overload Drive and Enclosure</b>					
A	3/4	4	SVXF072KBP	4	SVXF073KBP
	1		SVX0012KBP		SVX0013KBP
	2		SVX0022KBP		SVX0023KBP
	3		SVX0032KBP		SVX0033KBP
	5	5	SVX0052KBP	5	SVX0053KBP
	7-1/2		SVX0072KBP		SVX0073KBP
	10		SVX0102KBP		SVX0103KBP
	15	6	SVX0152KBP	6	SVX0153KBP
20		SVX0202KBP		SVX0203KBP	
B	25	7	SVX0252KAP	7	SVX0253KAP
	30		SVX0302KAP		SVX0303KAP
C	40	8	SVX0402KAP	8	SVX0403KAP
	50		SVX0502KAP		SVX0503KAP
	60		SVX0602KAP		SVX0603KAP

**Notes**

- ① Enclosure dimensions starting on **Page V6-T36-92**.
- ② Includes drive, local/remote keypad and enclosure.

## Options

### 9000X Series Option Board Kits

The 9000X Series drives can accommodate a wide selection of expander and adapter option boards to customize the drive for your application needs. The drive's control unit is designed to accept a total of five option boards.

The 9000X Series factory installed standard board configuration includes an A9 I/O board and an A2 relay output board, which are installed in slots A and B.

#### Option Boards

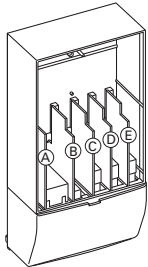

#### Option Board Kits

Option Kit Description <sup>①</sup>	Allowed Slot Locations <sup>②</sup>	Field Installed Catalog Number	Factory Installed Option Designator	SVX Ready Programs						
				Basic	Local/Remote	Standard	MSS	PID	Multi-P.	PFC
<b>Standard I/O Cards</b>										
2 RO (NC-NO)	B	<b>OPTA2</b>	—	■	■	■	■	■	■	■
6 DI, 1 DO, 2 AI, 1AO, 1 +10 Vdc ref, 2 ext +24 Vdc/EXT +24 Vdc	A	<b>OPTA9</b>	—	■	■	■	■	■	■	■
<b>Extended I/O Cards</b>										
6 DI, 1 ext +24 Vdc/EXT +24 Vdc	B, C, <b>D</b> , E	<b>OPTB1</b>	<b>B1</b>	—	—	—	—	—	■	■
1 RO (NC-NO), 1 RO (NO), 1 therm	B, C, <b>D</b> , E	<b>OPTB2</b>	<b>B2</b>	—	—	—	—	—	■	■
1 AI (mA isolated), 2 AO (mA isolated), 1 ext +24 Vdc/EXT +24 Vdc	B, C, <b>D</b> , E	<b>OPTB4</b>	<b>B4</b>	■	■	■	■	■	■	■
3 RO (NO)	B, C, <b>D</b> , E	<b>OPTB5</b>	<b>B5</b>	—	—	—	—	—	■	■
1 ext +24 Vdc/EXT +24 Vdc, 3 Pt100	B, C, <b>D</b> , E	<b>OPTB8</b>	<b>B8</b>	—	—	—	—	—	—	—
1 RO (NO), 5 DI 42–240 Vac input	B, C, <b>D</b> , E	<b>OPTB9</b>	<b>B9</b>	—	—	—	—	—	■	■
<b>Communication Cards <sup>③</sup></b>										
Modbus	D, <b>E</b>	<b>OPTC2</b>	<b>C2</b>	■	■	■	■	■	■	■
Modbus TCP	D, <b>E</b>	<b>OPTC1</b>	<b>C1</b>	■	■	■	■	■	■	■
BACnet	D, <b>E</b>	<b>OPTCJ</b>	<b>CJ</b>	■	■	■	■	■	■	■
Ethernet IP	D, <b>E</b>	<b>OPTCK</b>	<b>CK</b>	■	■	■	■	■	■	■
Johnson Controls N2	D, <b>E</b>	<b>OPTC2</b>	<b>CA</b>	—	—	—	—	—	—	—
Profibus DP	D, <b>E</b>	<b>OPTC3</b>	<b>C3</b>	■	■	■	■	■	■	■
LonWorks	D, <b>E</b>	<b>OPTC4</b>	<b>C4</b>	■	■	■	■	■	■	■
Profibus DP (D9 connector)	D, <b>E</b>	<b>OPTC5</b>	<b>C5</b>	■	■	■	■	■	■	■
CanOpen (slave)	D, <b>E</b>	<b>OPTC6</b>	<b>C6</b>	■	■	■	■	■	■	■
DeviceNet	D, <b>E</b>	<b>OPTC7</b>	<b>C7</b>	■	■	■	■	■	■	■
Modbus (D9 type connector)	D, <b>E</b>	<b>OPTC8</b>	<b>C8</b>	■	■	■	■	■	■	■
RS-232 with D9 connection	D, <b>E</b>	<b>OPTD3</b>	<b>D3</b>	■	■	■	■	■	■	■
<b>Keypad</b>										
9000X Series local/remote keypad	—	<b>KEYPAD-LOC/REM</b>	—	—	—	—	—	—	—	—
9000X Series remote mount keypad kit	—	<b>OPTRMT-KIT-9000X</b>	—	—	—	—	—	—	—	—
9000X Series RS-232 cable, 13 ft	—	<b>PP00104</b>	—	—	—	—	—	—	—	—

#### Notes

① AI = Analog Input; AO = Analog Output, DI = Digital Input, DO = Digital Output, RO = Relay Output

② Option card must be installed in one of the slots listed for that card. Slot indicated in bold is the preferred location.

③ OPTC2 is a multi-protocol option card.

**Modbus RTU Network Communications**

The Modbus Network Card OPTC2 is used for connecting the 9000X Drive as a slave on a Modbus network. The interface is connected by a 9-pin DSUB connector (female) and the baud rate ranges from 300 to 19200 baud. Other communication parameters include an address range from 1 to 247; a parity of None, Odd or Even; and the stop bit is 1.

**Profibus Network Communications**

The Profibus Network Card OPTC3 is used for connecting the 9000X Drive as a slave on a Profibus-DP network. The interface is connected by a 9-pin DSUB connector (female). The baud rates range from 9.6K baud to 12M baud, and the addresses range from 1 to 127.

**LonWorks Network Communications**

The LonWorks Network Card OPTC4 is used for connecting the 9000X Drive on a LonWorks network. This interface uses Standard Network Variable Types (SNVT) as data types. The channel connection is achieved using a FTT-10A Free Topology transceiver via a single twisted transfer cable. The communication speed with LonWorks is 78 kBits/s.

**CanOpen (Slave) Communications**

The CanOpen (Slave) Network Card OPTC6 is used for connecting the 9000X Drive to a host system. According to ISO11898 standard cables to be chosen for CAN bus should have a nominal impedance of 120 ohms, and specific line delay of nominal 5 nS/m. 120 ohms line termination resistors required for installation.

**DeviceNet Network Communications**

The DeviceNet Network Card OPTC7 is used for connecting the 9000X Drive on a DeviceNet Network. It includes a 5.08 mm pluggable connector. Transfer method is via CAN using a two-wire twisted shielded cable with two-wire bus power cable and drain. The baud rates used for communication include 125K baud, 250K baud and 500K baud.

**Johnson Controls Metasys N2 Network Communications**

The OPTC2 fieldbus board provides communication between the 9000X Drive and a Johnson Controls Metasys™ N2 network. With this connection, the drive can be controlled, monitored and programmed from the Metasys system. The N2 fieldbus is available as a factory installed option and as a field installable kit.

**Modbus/TCP Network Communications**

The Modbus/TCP Network Card OPTC1 is used for connecting the 9000X Drive to Ethernet networks utilizing Modbus protocol. It includes an RJ-45 pluggable connector. This interface provides a selection of standard and custom register values to communicate drive parameters. The board supports 10 Mbps and 100 Mbps communication speeds. The IP address of the board is configurable over Ethernet using a supplied software tool.

**BACnet Network Communications**

The BACnet Network Card OPTCJ is used for connecting the 9000X Drive to BACnet networks. It includes a 5.08 mm pluggable connector. Data transfer is Master-Slave/Token Passing (MS/TP) RS-485. This interface uses a collection of 30 Binary Value Objects (BVOs) and 35 Analog Value Objects (AVOs) to communicate drive parameters. The card supports 9.6, 19.2 and 38.4 Kbaud communication speeds and supports network addresses 1–127.

**Ethernet/IP Network Communications**

The Ethernet/IP Network Card OPTCK is used for connecting the 9000X Drive to Ethernet/Industrial Protocol networks. It includes an RJ-45 pluggable connector. The interface uses CIP objects to communicate drive parameters (CIP is “Common Industrial Protocol”, the same protocol used by DeviceNet). The board supports 10 Mbps and 100 Mbps communication speeds. The IP address of the board is configurable by Static, BOOTP and DHCP methods.

**Control/Communication Option Descriptions**

For availability, see Product Selection for base drive voltage required.

**Available Control/Communications Options**

Option	Description	Option Type
<b>K1</b>	<b>Door-Mounted Speed Potentiometer</b> —Provides the SVX9000 with the ability to adjust the frequency reference using a door-mounted potentiometer. This option uses the 10 Vdc reference to generate a 0–10V signal at the analog voltage input signal terminal. When the HOA bypass option is added, the speed is controlled when the HOA switch is in the HAND position. Without the HOA bypass option, a two-position switch (labeled local/remote) is provided on the keypad to select speed reference from the Speed Potentiometer or a remote speed signal.	Control
<b>K2</b>	<b>Door-Mounted Speed Potentiometer with HOA Selector Switch</b> —Provides the SVX9000 with the ability to start/stop and adjust the speed reference from door-mounted control devices or remotely from customer supplied inputs. In HAND position, the drive will start and the speed is controlled by the door-mounted speed potentiometer. The drive will be disabled in the OFF position. When AUTO is selected, the drive run and speed control commands are via user-supplied dry contact and 4–20 mA signal.	Control
<b>K5</b>	<b>MANUAL/AUTO Speed Reference Switch</b> —Provides a door-mounted selector switch for MANUAL/AUTO speed reference.	Control
<b>K6</b>	<b>START and STOP Pushbuttons (22 mm)</b> —START (green) STOP (red). Provide door-mounted START and STOP pushbuttons for either bypass or non-bypass configurations.	Control
<b>K9</b>	<b>(2) Factory Installed Auxiliary Contacts</b> —Provide two NO/NC auxiliary contacts.	Power
<b>L1</b>	<b>Power On and Fault Pilot Lights</b> —Provide a white power on light that indicates power to the enclosed cabinet and a red fault light that indicates a drive fault has occurred.	Light
<b>L2</b>	<b>Bypass Pilot Lights for RB, RA Bypass Options</b> —A green light indicates when the motor is running in inverter mode and an amber light indicates when the motor is running in bypass mode. The lights are mounted on the enclosure door, above the switches.	Addl. Bypass
<b>LD</b>	<b>Green STOP Light (22 mm)</b> —Provides a green light that indicates the drive is stopped.	Light
<b>LE</b>	<b>Red RUN Pilot Light (22 mm)</b> —Provides a red run pilot light that indicates the drive is running.	Light
<b>LU</b>	<b>Misc. Light (22 mm)</b> —Provides a misc. “user defined” pilot light. User to define light function and color.	Light
<b>LW</b>	<b>PTT (Push-To-Test) Light (22 mm)</b> —Provides misc. “user defined” PTT pilot light. User to define light function and color.	Light
<b>LY</b>	<b>Adder for LED Each</b> —Changes light packages from standard incandescent bulb to LED style bulb.	Light
<b>P1</b>	<b>Input Disconnect Assembly Rated to 100 kAIC</b> —High Interrupting Motor Circuit Protector (HMCP) that provides a means of short circuit protection for the power cables between it and the SVX9000, and protection from high-level ground faults on the power cable. Allows a convenient means of disconnecting the SVX9000 from the line and the operating mechanism can be padlocked in the OFF position. This is factory mounted in the enclosure.	Input
<b>P3</b>	<b>Input Line Fuses Rated to 200 kAIC</b> —Provide high-level fault protection of the SVX9000 input power circuit from the load side of the fuses to the input side of the power transistors. This option consists of three 200 kA fuses, which are factory mounted in the enclosure.	Input
<b>P7</b>	<b>MOV Surge Suppressor</b> —Provides a Metal Oxide Varistor (MOV) connected to the line side terminals and is designed to clip line side transients.	Input
<b>P8</b>	<b>TVSS Transient Voltage Surge Suppressor</b> —Provides transient voltage surge suppression of the unit. Consult factory for ratings.	Input
<b>PE</b>	<b>Output Contactor</b> —Provides a means for positive disconnection of the drive output from the motor terminals. The contactor coil is controlled by the drive’s run or permissive logic. NC and NO auxiliary contacts rated at 10A, 600 Vac are provided for customer use. Bypass option <b>RA</b> includes an output contactor as standard. This option includes a low VA 115 Vac fused control power transformer and is factory mounted in the enclosure.	Output
<b>RA</b>	<b>Manual HOA Bypass Controller</b> —The Manual HAND/OFF/AUTO (HOA)—3-contactor—bypass option provides a means of bypassing the SVX9000, allowing the AC motor to be operated at full speed directly from the AC supply line. This option consists of an input disconnect, a fused control power transformer, and a full voltage bypass starter with a door mounted HOA selector switch and an INVERTER/BYPASS switch. The HOA switch provides the ability to start and stop the drive in the inverter mode. For applications up to 100 hp, a Freedom Series IEC input contactor, a Freedom Series IEC output contactor, and a Freedom Series IEC starter with a bimetallic overload relay is included. For applications above 100 hp, an Advantage input contactor, an Advantage output contactor and an Advantage starter with electronic overload protection is included. The contactors are mechanically and electrically interlocked (see power diagram on <b>Page V6-T36-91</b> ).	Bypass
<b>S5</b>	<b>Floor Stand 22 in</b> —Converts a Size A or B, normally wall mounted enclosure to a floor standing enclosure with a height of 22 in (558.8 mm).	Enclosure
<b>S9</b>	<b>Space Heater without CPT</b> —Prevents condensation from forming in the enclosure when the drive is inactive or in storage. Includes a thermostat for variable temperature control. A 200W heater is installed in enclosures A and B, and 400W heater is installed in enclosures C and D. Requires a customer supplied 115V remote supply source.	Enclosure
<b>SA</b>	<b>Space Heater with CPT</b> —Prevents condensation from forming in the enclosure when the drive is inactive or in storage. Includes a thermostat for variable temperature control. A 200W heater is installed in enclosures A and B, and 400W heater is installed in enclosures C and D. Provided with CPT connected to load side of input disconnect.	Enclosure
<b>SB</b>	<b>Ice Cube Style Control Relay</b> —Provides misc. “user defined” 4PDT control relay. Requires user to define functionality.	Enclosure
<b>SE</b>	<b>On-Delay Timer (Delay on Make)</b> —Provides misc. “user defined” time delay relay. Requires user to define functionality and time setting requirement.	Enclosure
<b>SF</b>	<b>Off-Delay Timer (Delay on Break)</b> —Provides misc. “user defined” time delay relay. Requires user to define functionality and time setting requirement.	Enclosure

**VFD Pump Panel Options****Brake Chopper Options** <sup>①</sup>

208V and 230V: NEMA Type 12/IP54/3R, I<sub>H</sub> hp 3/4 to 100;  
I<sub>L</sub> hp 1 to 100  
480V: NEMA Type 12/IP54/3R, I<sub>H</sub> hp 1 to 400; I<sub>L</sub> hp 1-1/2 to 400

**208V and 230V Control Options, 3/4–100 hp** <sup>②</sup>

Description	Catalog Number Suffix
Door-mounted speed potentiometer	K1
Door-mounted speed potentiometer with HOA selector switch	K2
Manual/auto reference switch (22 mm)	K5
START and STOP pushbuttons (22 mm)	K6

**480V Control Options, 1–800 hp** <sup>②</sup>

Description	Catalog Number Suffix
Door-mounted speed potentiometer	K1
Door-mounted speed potentiometer with HOA selector switch	K2
Manual/auto reference switch (22 mm)	K5
START and STOP pushbuttons (22 mm)	K6

**208V and 230V Light Options, 3/4–100 hp** <sup>②</sup>

Description	Catalog Number Suffix
Power on/fault pilot lights (22 mm)	L1
Green STOP light (22 mm)	LD
Red RUN light (22 mm)	LE
Misc. light (22 mm)	LU
PTT light (22 mm)	LW
LED	LY

**480V Light Options, 1–800 hp** <sup>②</sup>

Description	Catalog Number Suffix
Power on/fault pilot lights (22 mm)	L1
Green STOP light (22 mm)	LD
Red RUN light (22 mm)	LE
Misc. light (22 mm)	LU
PTT light (22 mm)	LW
LED	LY

**Notes**

- ① External dynamic braking resistors not included. Consult factory.
- ② Consult factory for adder information.
- ③ See **Page V6-T36-87** for details.
- ④ Bypass options applicable only in the pump panel three-phase design.

**208V, 230V and 480V Enclosure Options, Sizes A–D** <sup>②</sup>

Description	Catalog Number Suffix
Floor stand 22 in (558.8 mm)	S5
Space heater without CPT	S9
Space heater with CPT	SA
Socket type control relay	SB
On-delay timer	SE
Off-delay timer	SF

**208 and 230V Power Options, 3/4–100 hp** <sup>②</sup>

Description	Catalog Number Suffix
Two auxiliary contacts installed	K9
Input disconnect (HMCP) 100 kAIC	P1
Input line fuses 200 kAIC	P3
Input power surge protection	P7
TVSS transient voltage surge suppressor	P8
Output contactor	PE

**480V Power Options, 1–400 hp** <sup>②</sup>

Description	Catalog Number Suffix
Two auxiliary contacts installed	K9
Input disconnect (HMCP) 100 kAIC	P1
Input line fuses 200 kAIC	P3
Input power surge protection	P7
TVSS transient voltage surge suppressor	P8
Output contactor	PE

**208 and 230V Bypass Options, 3/4–100 hp** <sup>②③</sup>

Description	Catalog Number Suffix
Bypass pilot lights for RA option	L2 <sup>④</sup>
Manual HOA bypass controller	RA <sup>④</sup>

**480V Bypass Options, 1–400 hp** <sup>②③</sup>

Description	Catalog Number Suffix
Bypass pilot lights for RA option	L2 <sup>④</sup>
Manual HOA bypass controller	RA <sup>④</sup>



## Technical Data and Specifications

### 9000X VFD Pump Panels

Description	NEMA Type 12/IP54 or NEMA Type 3R Specification
<b>Primary Design Features</b>	
45–66 Hz input frequency	Standard
Output (AC volts maximum)	Input voltage base
Output frequency range	0–320 Hz
Initial output current ( $I_H$ )	250% for 2 seconds
Overload (1 minute [ $I_H/I_L$ ])	150%/110%
Enclosure space heater	Optional
Oversize enclosure	Standard
Output contactor	Optional
Bypass motor starter	Optional
Listings	UL, cUL
<b>Protection Features</b>	
Incoming line fuses	Optional
AC input circuit disconnect	Optional
Line reactors	Standard
Phase rotation insensitive	Standard
EMI filter	Standard—Thru Frame 9
Input phase loss protection	Standard
Input overvoltage protection	Standard
Line surge protection	Standard
Output short circuit protection	Standard
Output ground fault protection	Standard
Output phase protection	Standard
Overtemperature protection	Standard
DC overvoltage protection	Standard
Drive overload protection	Standard
Motor overload protection	Standard
Programmer software	Optional
Local/remote keypad	Standard
Keypad lockout	Standard
Fault alarm output	Standard
Built-in diagnostics	Standard

Description	NEMA Type 12/IP54 or NEMA Type 3R Specification
<b>Input/Output Interface Features</b>	
Setup adjustment provisions	
Remote keypad/display	Standard
Personal computer	Standard
Operator control provisions	
Drive mounted keypad/display	Standard
Remote keypad/display	Standard
Conventional control elements	Standard
Serial communications	Optional
115 Vac control circuit	Optional
Speed setting inputs	
Keypad	Standard
0–10 Vdc potentiometer/voltage signal	Standard
4–20 mA isolated	Configurable
4–20 mA differential	Configurable
Analog outputs	
Speed/frequency	Standard
Torque/load/current	Programmable
Motor voltage	Programmable
Kilowatts	Programmable
0–10 Vdc signals	Configurable w/jumpers
4–20 mA DC signals	Standard
Isolated signals	Optional
Discrete outputs	
Fault alarm	Standard
Drive running	Standard
Drive at set speed	Programmable
Optional parameters	14
Dry contacts	1 (2 relays Form C)
Open collector outputs	1
Additional discrete outputs	Optional
Communications	
RS-232	Standard
RS-422/485	Optional
DeviceNet™	Optional
Modbus RTU	Optional
CanOpen (slave)	Optional
Profibus-DP	Optional
Lonworks®	Optional
Johnson Controls Metasys™ N2	Optional

## 9000X VFD Pump Panels, continued

Description	NEMA Type 12/IP54 or NEMA Type 3R Specification
<b>Performance Features</b>	
Sensorless vector control	Standard
Volts/hertz control	Standard
IR and slip compensation	Standard
Electronic reversing	Standard
Dynamic braking	Optional <sup>①</sup>
DC braking	Standard
PID setpoint controller	Programmable
Critical speed lockout	Standard
Current (torque) limit	Standard
Adjustable acceleration/deceleration	Standard
Linear or S curve accel/decel	Standard
Jog at preset speed	Standard
Thread/preset speeds	7
Automatic restart	Selectable
Coasting motor start	Standard
Coast or ramp stop selection	Standard
Elapsed time meter	Optional
Carrier frequency adjustment	1–16 kHz
<b>Standard Conditions for Application and Service</b>	
Operating ambient temperature	0 to 40°C
Storage temperature	–40 to 60°C
Humidity (maximum), non-condensing	95%
Altitude (maximum without derate)	3300 ft (1000m)
Line voltage variation	+10/–15%
Line frequency variation	45–66 Hz
Efficiency	>96%
Power factor (displacement)	0.96

## Standard I/O Specifications

Description	Specification
Six–digital input programmable	24V: "0" ≤10V, "1" ≥18V, R <sub>i</sub> >5 kohms
Two–analog input configurable w/jumpers	Voltage: 0–±10V, R <sub>i</sub> >200 kohms Current: 0 (4)–20 mA, R <sub>i</sub> = 250 ohms
Two–digital output programmable	Form C relays 250 Vac 30 Vdc 2 amp resistive
One–analog output programmable configurable w/jumper	0–20 mA, R <sub>L</sub> max. 500 ohms 10 bits ±2%
One digital output programmable	Open collector 48 Vdc 50 mA

## I/O Specifications for Control/Communication Options

Description	Specification
Analog voltage, input	0–±10V, R <sub>i</sub> ≥200 kohms
Analog current, input	0 (4)–20 mA, R <sub>i</sub> = 250 ohms
Digital input	24V: "0" ≤10V, "1" ≥18V, R <sub>i</sub> >5 kohms
Auxiliary voltage	24V (±20%), max. 50 mA
Reference voltage	10V ±3%, max. 10 mA
Analog current, output	0 (4)–20 mA, R <sub>L</sub> = 500 kohms, resolution 10 bit, accuracy ≤±2%
Analog voltage, output	0 (2)–10V, R <sub>L</sub> ≥1 k kohms, resolution 10 bit, accuracy ≤±2%
Relay output	
Maximum switching voltage	300 Vdc, 250 Vac
Maximum switching load	8A/24 Vdc, 0.4A/300 Vdc, 2 kVA/250 Vac
Maximum continuous load	2A rms
Thermistor input	R <sub>trip</sub> = 4.7 kohms

**Note**

<sup>①</sup> Some horsepower units include dynamic braking chopper as standard—refer to individual drive sections.

### Wiring Diagrams

#### Power Diagram for Bypass Option RA

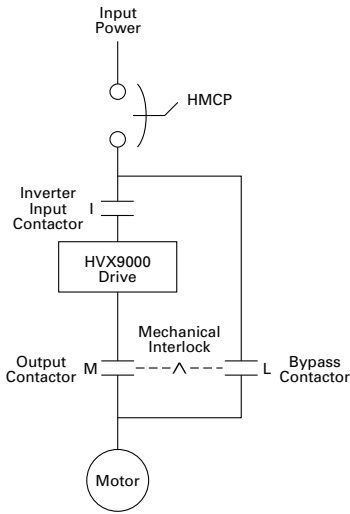

#### SVX9000 Pump Panel Bypass Power Wiring

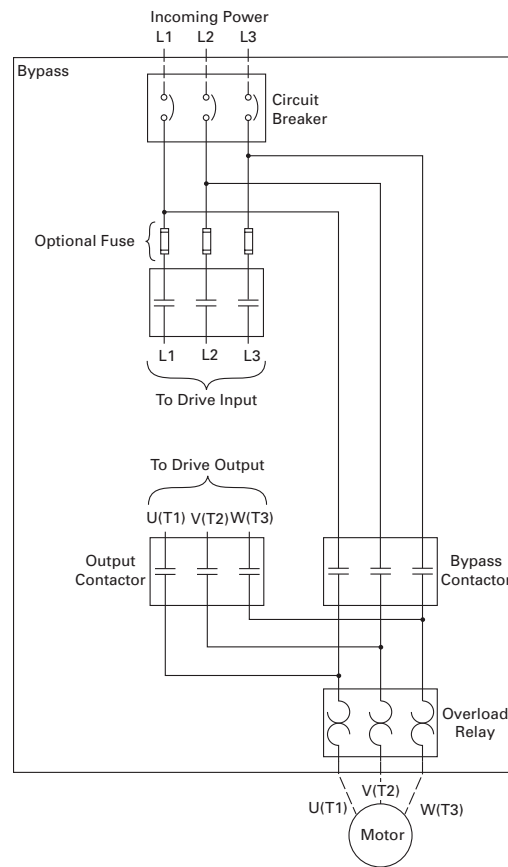

#### A2 Board Control Wiring

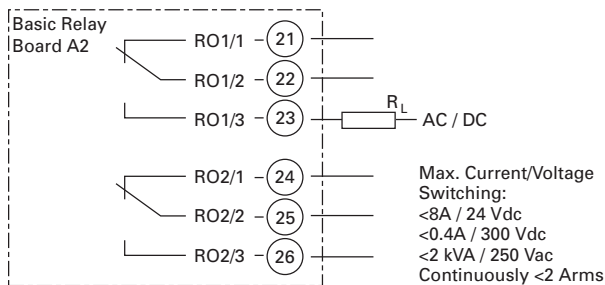

#### A9 Board Control Wiring

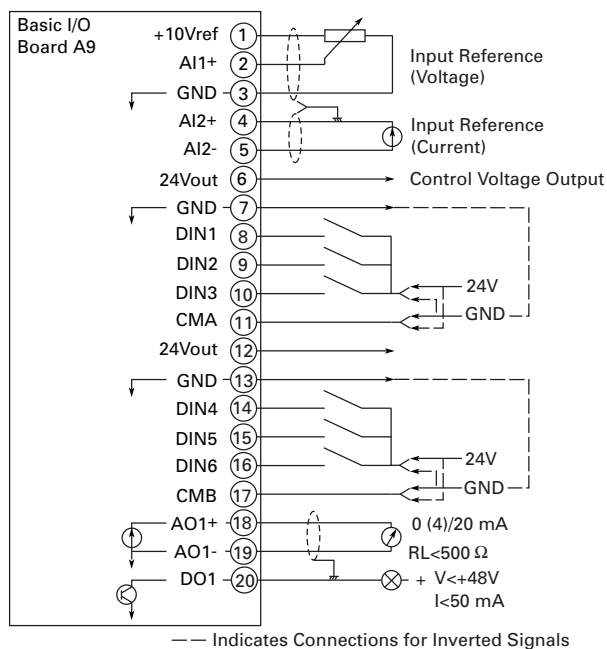

#### SVX9000 Pump Panel Disconnect Power Wiring

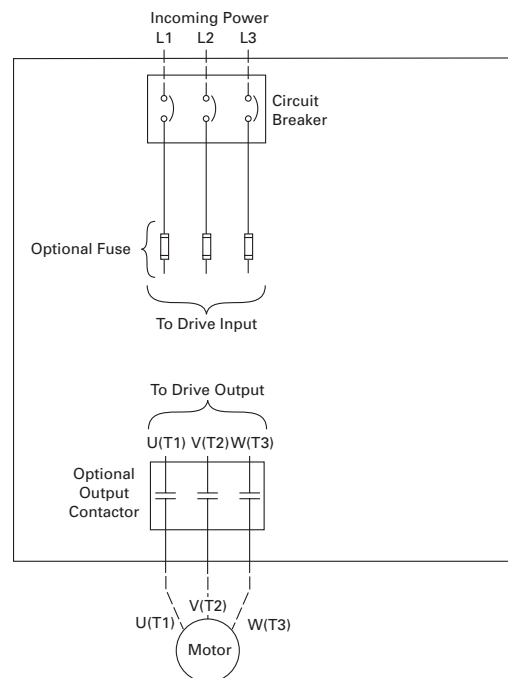

# 36.3

## Adjustable Frequency Drives

### SVX9000 Drives

#### Dimensions

Approximate Dimensions in Inches (mm)

36

#### SVX9000 Pump Application Drives

#### Enclosure Box A NEMA Type 12/IP54

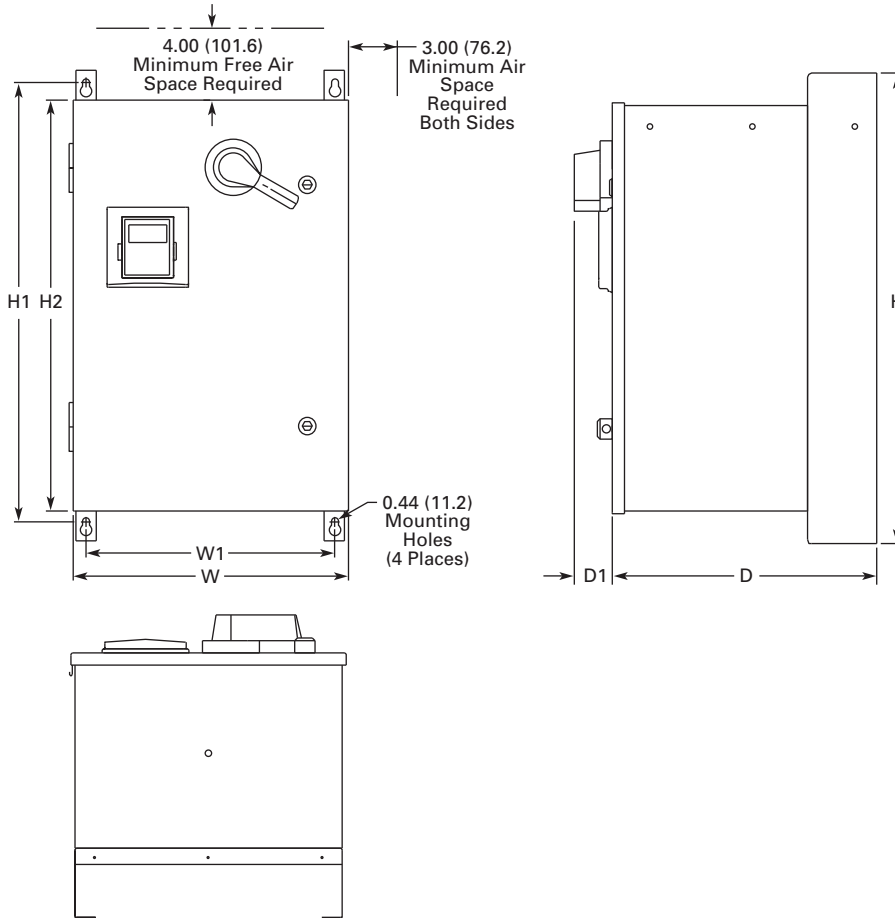

Voltage AC	hp (I <sub>H</sub> )	hp (I <sub>L</sub> )	H	H1	H2	W	W1	D	D1	Approx. Weight Lbs (kg)	Approx. Shipping Weight Lbs (kg)
<b>Three-Phase</b>											
208V	3/4–10	1–15	29.00	27.00	25.35	16.92	15.30	16.26	2.34	120 (54)	160 (73)
230V	3/4–10	1–15	(736.6)	(685.8)	(643.9)	(429.8)	(388.6)	(413.0)	(59.4)		
480V	1–25	1–30									
<b>Single-Phase</b>											
230V	—	3/4–10	29.00	27.00	25.35	16.92	15.30	16.26	2.34	120 (54)	160 (73)
480V	—	3/4–20	(736.6)	(685.8)	(643.9)	(429.8)	(388.6)	(413.0)	(59.4)		

Approximate Dimensions in Inches (mm)

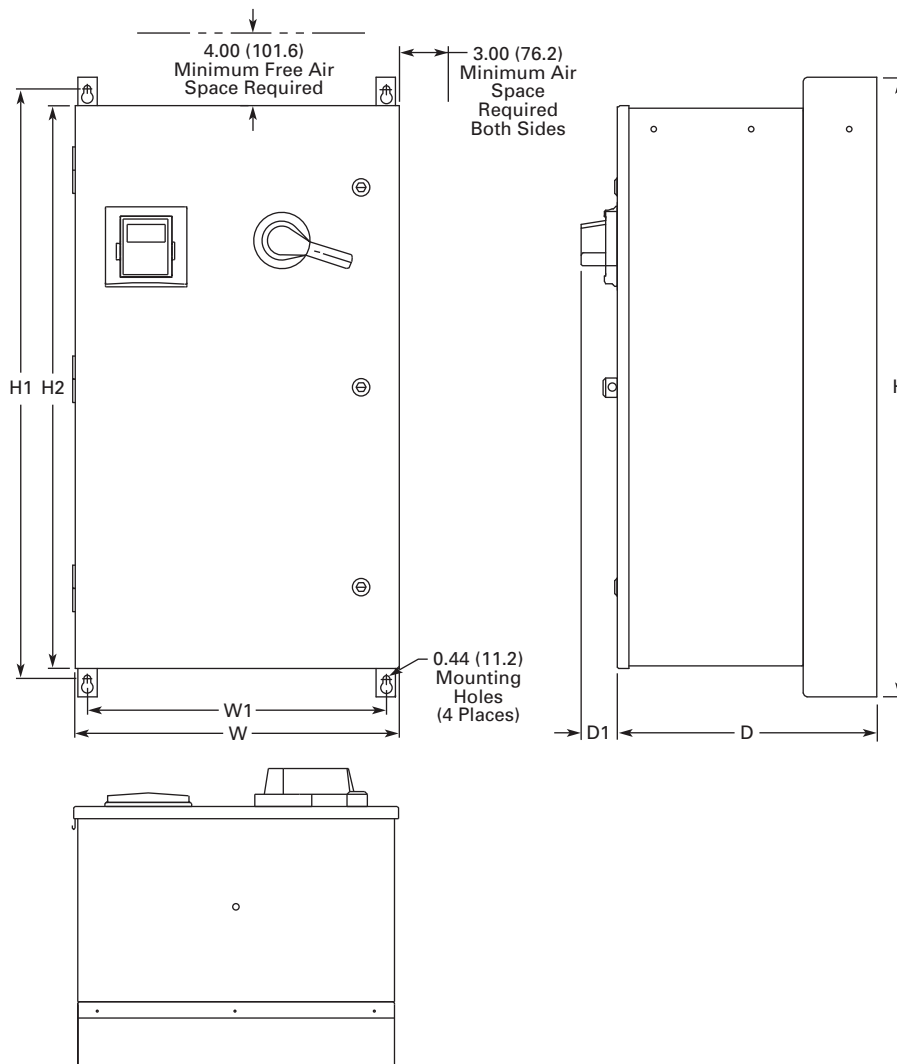
**Enclosure Box B NEMA Type 12/IP54**

Voltage AC	hp (I <sub>H</sub> )	hp (I <sub>L</sub> )	H	H <sub>1</sub>	H <sub>2</sub>	W	W <sub>1</sub>	D	D <sub>1</sub>	Approx. Weight Lbs (kg)	Approx. Shipping Weight Lbs (kg)
<b>Three-Phase</b>											
208V	15–25	20–30	40.00	38.00	36.35	20.92	19.30	16.76	2.34	185 (84)	229 (104)
230V	15–25	20–30	(1016.0)	(965.2)	(923.3)	(531.4)	(490.2)	(425.7)	(59.4)		
480V	30–60	40–75									
<b>Single-Phase</b>											
230V	—	15–20	40.00	38.00	36.35	20.92	19.30	16.76	2.34	185 (84)	229 (104)
480V	—	25–30	(1016.0)	(965.2)	(923.3)	(531.4)	(490.2)	(425.7)	(59.4)		

# 36.3

## Adjustable Frequency Drives

### SVX9000 Drives

Approximate Dimensions in Inches (mm)

#### Enclosure Box C NEMA Type 12/IP54

36

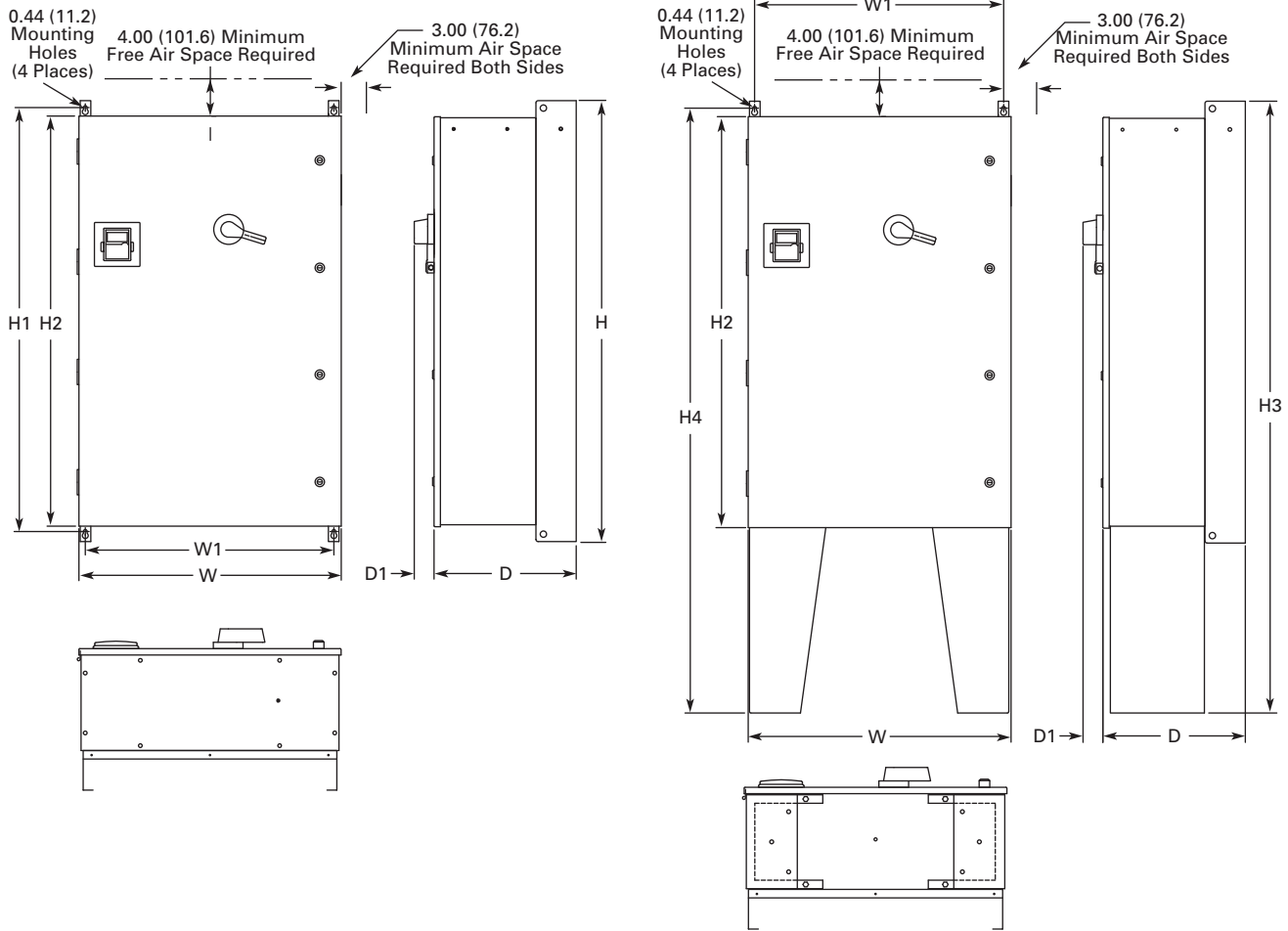

Voltage AC	hp (I <sub>H</sub> )	hp (I <sub>L</sub> )	H	H1	H2	H3	H4	W	W1	D	D1	Approx. Shipping Weight Lbs (kg)
<b>Three-Phase</b>												
208V	30–50	40–60	52.00 (1320.8)	50.00 (1270.0)	48.35 (1228.1)	72.00 (1828.8)	71.19 (1808.2)	30.92 (785.4)	29.30 (744.2)	16.78 (426.2)	2.34 (59.4)	①
230V	30–50	40–60										
480V	75–125	100–150										
<b>Single-Phase</b>												
230V	—	25–40	52.00 (1320.8)	50.00 (1270.0)	48.35 (1228.1)	72.00 (1828.8)	71.19 (1808.2)	30.92 (785.4)	29.30 (744.2)	16.78 (426.2)	2.34 (59.4)	①
480V	—	40–60										

**Note**  
① Consult factory.

Approximate Dimensions in Inches (mm)

## Enclosure Box A NEMA Type 3R

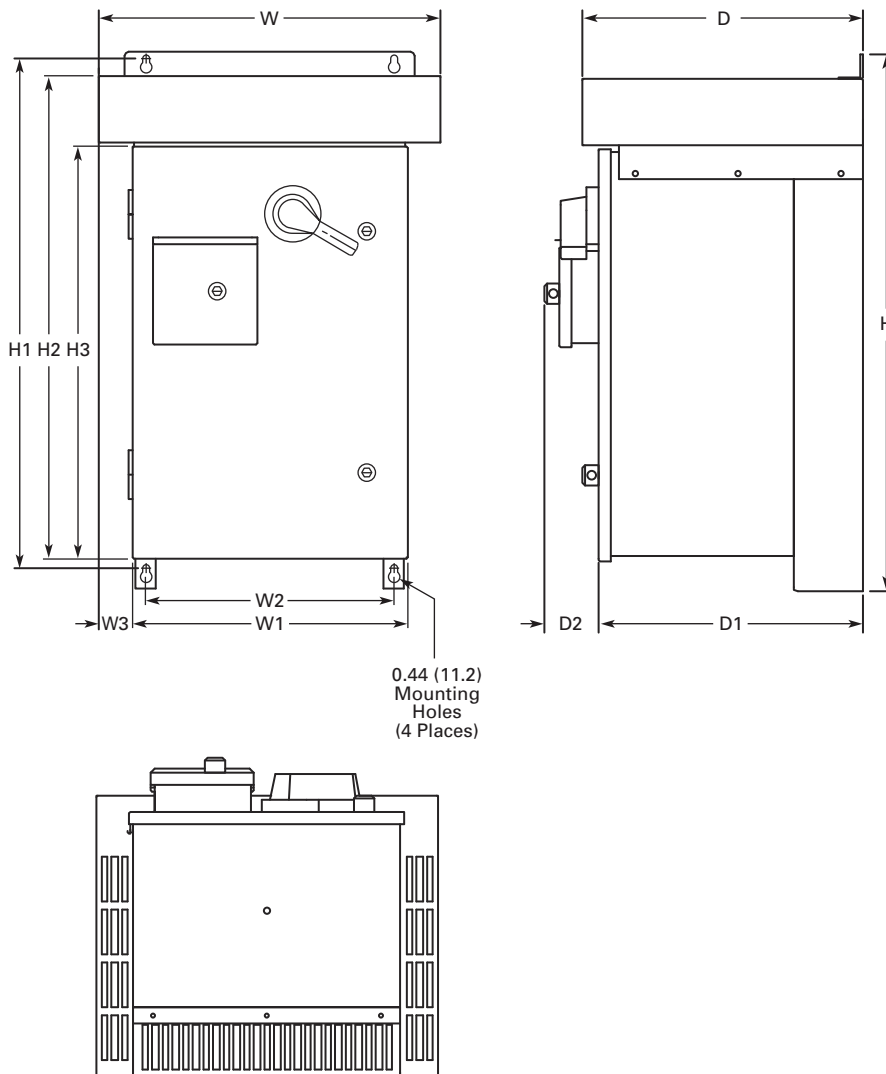

Voltage AC	hp (I <sub>H</sub> )	hp (I <sub>L</sub> )	H	H1	H2	H3	W	W1	W2	W3	D	D1	D2	Approx. Weight Lbs (kg)	Approx. Shipping Weight Lbs (kg)
<b>Three-Phase</b>															
208V	3/4–10	1–15	33.00 (838.2)	31.36 (796.5)	29.67 (753.6)	25.35 (643.9)	21.05 (534.7)	16.92 (429.8)	15.30 (388.6)	2.07 (52.6)	17.24 (437.9)	16.26 (413.0)	3.31 (84.1)	170 (77)	215 (98)
230V	3/4–10	1–15													
480V	1–25	1–30													
<b>Single-Phase</b>															
230V	—	3/4–10	33.00 (838.2)	31.36 (796.5)	29.67 (753.6)	25.35 (643.9)	21.05 (534.7)	16.92 (429.8)	15.30 (388.6)	2.07 (52.6)	17.24 (437.9)	16.26 (413.0)	3.31 (84.1)	170 (77)	215 (98)
480V	—	3/4–20													

# 36.3

## Adjustable Frequency Drives

SVX9000 Drives

Approximate Dimensions in Inches (mm)

### Enclosure Box B NEMA Type 3R

36

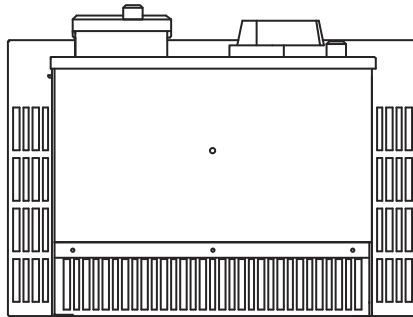
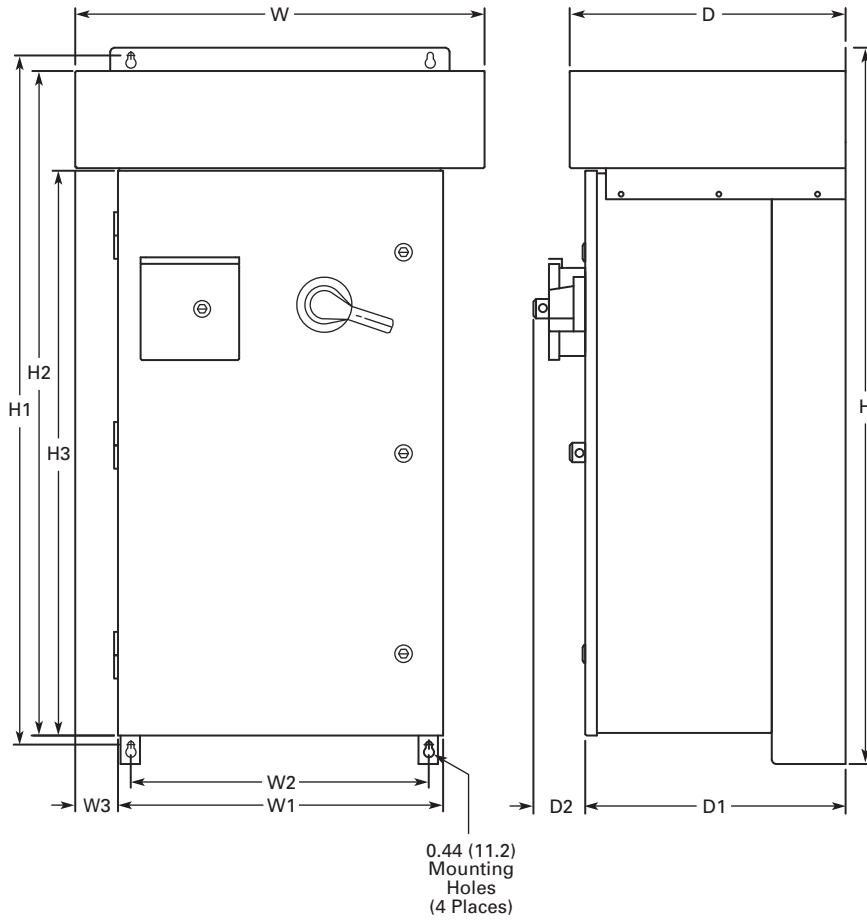

Voltage AC	hp (I <sub>H</sub> )	hp (I <sub>L</sub> )	H	H1	H2	H3	W	W1	W2	W3	D	D1	D2	Approx. Weight Lbs (kg)	Approx. Shipping Weight Lbs (kg)
<b>Three-Phase</b>															
208V	15–25	20–30	46.09	44.45	42.77	36.35	26.31	20.92	19.30	2.69	17.74	16.76	3.31	235	290
230V	15–25	20–30	(1170.7)	(1129.0)	(1086.4)	(923.3)	(668.3)	(531.4)	(490.2)	(68.3)	(450.6)	(425.7)	(840.1)	(107)	(132)
480V	30–60	40–75													
<b>Single-Phase</b>															
230V	—	15–20	46.09	44.45	42.77	36.35	26.31	20.92	19.30	2.69	17.74	16.76	3.31	235	290
480V	—	25–30	(1170.7)	(1129.0)	(1086.4)	(923.3)	(668.3)	(531.4)	(490.2)	(68.3)	(450.6)	(425.7)	(840.1)	(107)	(132)



Approximate Dimensions in Inches (mm)

## Enclosure Box C NEMA Type 3R

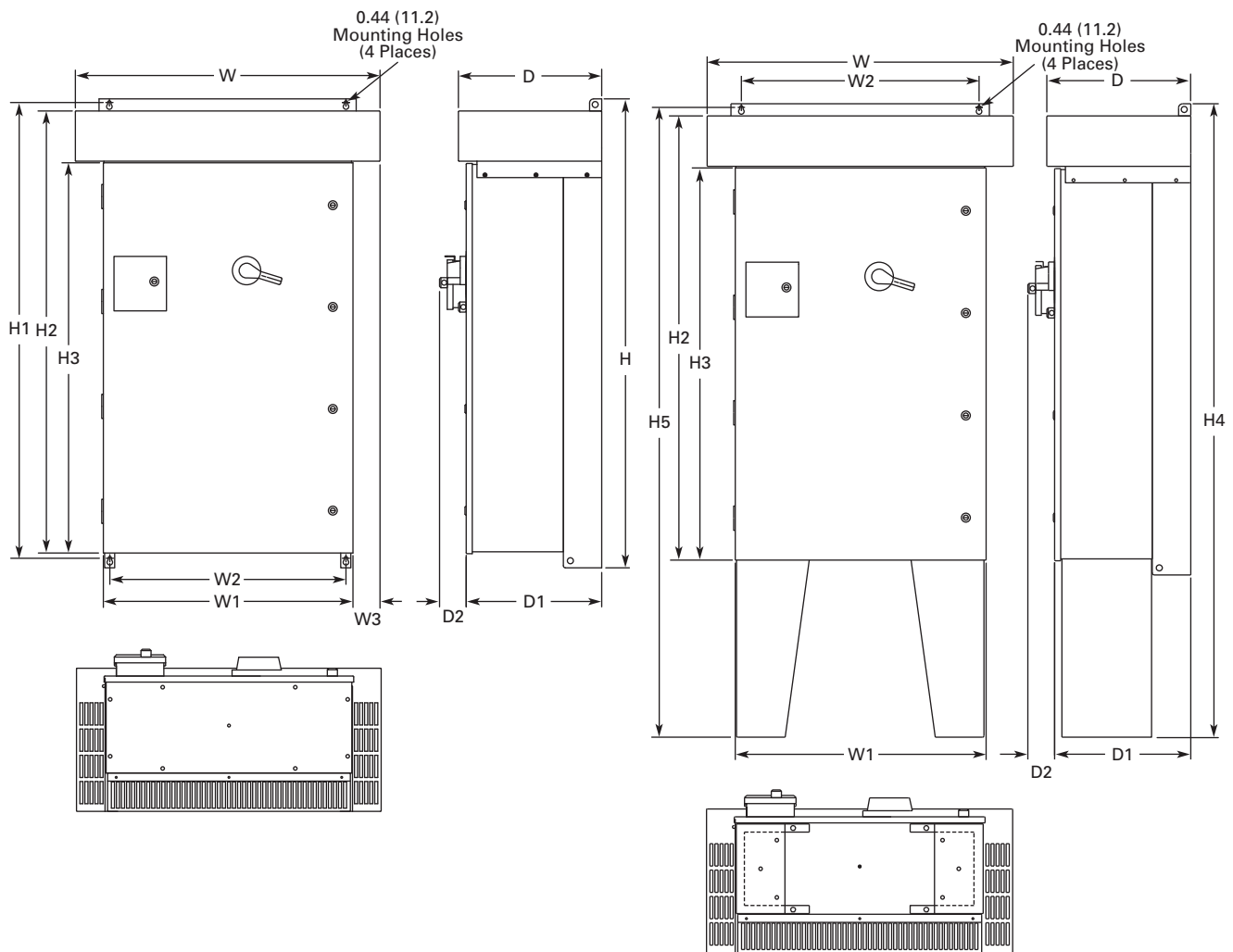

Voltage AC	hp (I <sub>H</sub> )	hp (I <sub>L</sub> )	H	H1	H2	H3	H4	H5	W	W1	W2	W3	D	D1	D2	Approx. Weight Lbs (kg)
<b>Three-Phase</b>																
208	30–50	40–60	58.09 (1475.5)	56.45 (1433.8)	54.77 (1391.2)	48.35 (1228.1)	78.09 (1983.5)	77.64 (1972.1)	37.73 (958.3)	30.92 (785.4)	29.30 (744.2)	3.34 (84.8)	17.74 (450.6)	16.77 (426.0)	3.31 (840.1)	①
230	30–50	40–60														
480	75–125	100–150														
<b>Single-Phase</b>																
230V	—	25–40	58.09 (1475.5)	56.45 (1433.8)	54.77 (1391.2)	48.35 (1228.1)	78.09 (1983.5)	77.64 (1972.1)	37.73 (958.3)	30.92 (785.4)	29.30 (744.2)	3.34 (84.8)	17.74 (450.6)	16.77 (426.0)	3.31 (840.1)	①
480V	—	40–60														

**Note**

① Consult factory.

SPX9000 Drives

36



### Contents

#### Description

Page

SPX9000 Drives	
Features and Benefits	<b>V6-T36-99</b>
Standards and Certifications	<b>V6-T36-99</b>
Catalog Number Selection	<b>V6-T36-100</b>
Product Selection	<b>V6-T36-101</b>
Accessories	<b>V6-T36-106</b>
Options	<b>V6-T36-107</b>
Replacement Parts	<b>V6-T36-112</b>
Technical Data and Specifications	<b>V6-T36-120</b>
Dimensions	<b>V6-T36-121</b>

### Product Description

The SPX9000 Series Adjustable Frequency Drives from Eaton's electrical sector are specifically designed for high performance applications. Equipped with high processing power, the SPX9000 can use information from an encoder or a resolver in order to provide very precise motor control. Sensorless vector and simple frequency control are also supported. Typical applications requiring high performance are: master-slave drives, positioning applications, winder tension control and synchronization.

The core of the SPX9000 is a fast microprocessor, providing high dynamic performance for applications where good motor handling and reliability are required. It can be used both in open loop applications as well as in applications requiring encoder feedback.

The SPX9000 supports fast drive-to-drive communication. It also offers an integrated data logger functionality for analysis of dynamic events without the need of additional hardware. Simultaneous fast monitoring of several drives can be done by using the 9000Xdrive tool and CAN communication. In applications where reliability and quality are essential for high-performance, the SPX9000 is the logical choice.

The Eaton family of drives includes HVX9000, H-Max, M-Max, SVX9000, SLX9000 and SPX9000. 9000X Series drive ratings are rated for either high overload ( $I_H$ ) or low overload ( $I_L$ ).  $I_L$  indicates 110% overload capacity for 1 minute out of 10 minutes.  $I_H$  indicates 150% overload capacity for 1 minute out of 10 minutes.

## Features and Benefits

- Speed error <0.01%, depending on the encoder
- Incremental or absolute encoder support
- Encoder voltages of 5V (RS-422), 15V or 24V, depending on the option card
- Full torque control at all speeds, including zero
- Torque accuracy <2%; <5% down to zero speed
- Starting torque >200%, depending on motor and drive sizing
- Integrated datalogger for system analysis
- Fast multiple drive monitoring with PC
- Full capability for master/slave configurations
- High-speed bus (12 Mbit/s) for fast inter-drive communication
- High-speed applications (up to 7200 Hz) possible
- Robust design—proven 500,000 hours MTBF
- Integrated 3% line reactors standard on drives from FR4 through FR9
- Line reactor is included but is separated from chassis
- EMI/RFI Filters H standard up to 200 hp I<sub>H</sub> 480V, 100 hp I<sub>H</sub> 230V
- Simplified operating menu allows for typical programming changes, while programming mode provides control of everything
- Quick Start Wizard built into the programming of the drive ensures a smooth start-up
- Keypad can display up to three monitored parameters simultaneously
- LOCAL/REMOTE operation from keypad
- Copy/paste function allows transfer of parameter settings from one drive to the next
- Standard NEMA Type 12/IP54 keypad on all drives
- Hand-held auxiliary 240 power supply allows programming/monitoring of control module without applying full power to the drive
- The SPX can be flexibly adapted to a variety of needs using our pre-installed “Seven in One” precision application programs consisting of:
  - Basic
  - Standard
  - Local/remote
  - Multi-step speed control
  - PID control
  - Multi-purpose control
  - Pump and fan control with auto change
- Additional I/O and communication cards provide plug and play functionality
- I/O connections with simple quick connection terminals
- Control logic can be powered from an external auxiliary control panel, internal drive functions and fieldbus if necessary
- Brake chopper standard from: 1–30 hp/380–500V 3/4–15 hp/208–230V
- NEMA Type 1/IP21 enclosures available Frame Sizes FR4–FR11, NEMA Type 12/IP54 enclosures available Frame Sizes FR4–FR10 (FR10 and FR11 freestanding drives)
- Open chassis FR10 and greater
- Standard option board configuration includes an A9 I/O board and an A2 relay output board installed in slots A and B

## Standards and Certifications

### Product

- IEC 61800-2

### Safety

- UL 508C

### EMC (at default settings)

- Immunity: Fulfills all EMC immunity requirements; Emissions: EN 61800-3, LEVEL H

- UL Listed



# 36.4

## Adjustable Frequency Drives

### SPX9000 Drives

36

### Catalog Number Selection

#### SPX9000 Adjustable Frequency Drives

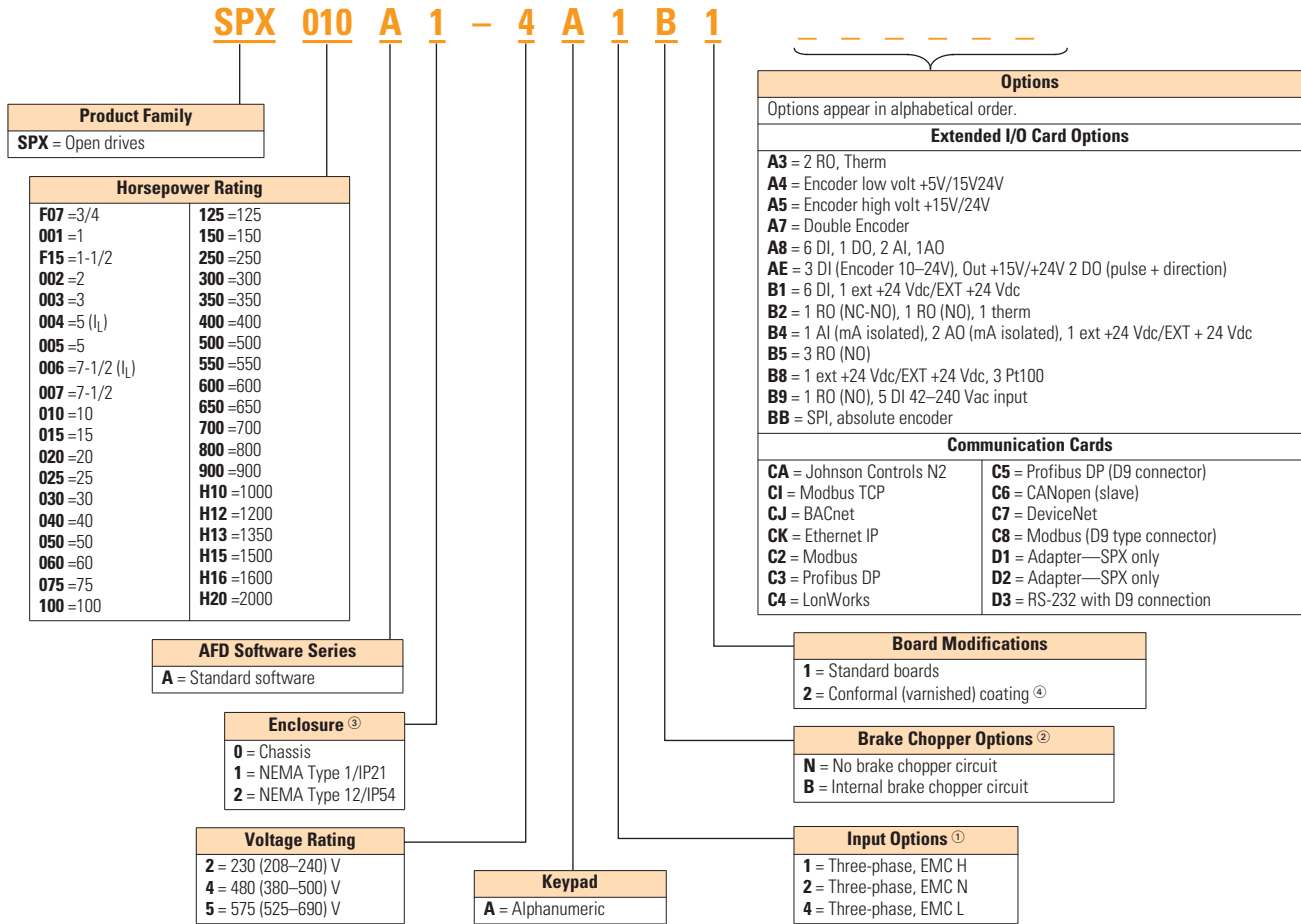

### Power Module

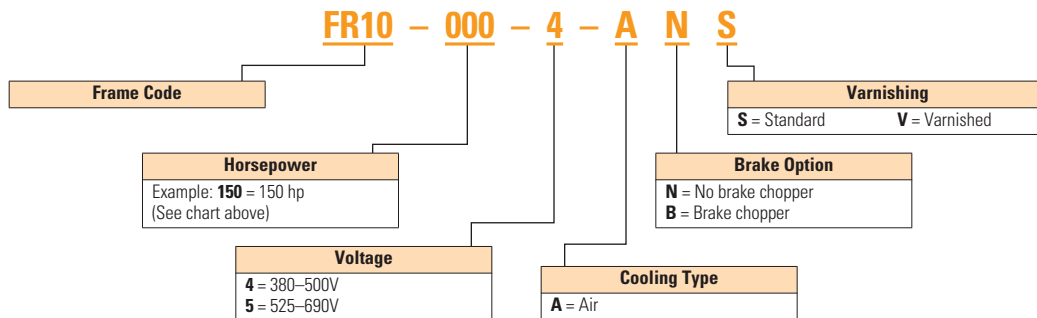

#### Notes

- All 230V drives and 480V drives up to 200 hp (I<sub>L</sub>) are only available with input option 1 (EMC level H). 480V drives 250 hp (I<sub>L</sub>) or larger are available with input option 2 (EMC level N). 575V drives 200 hp (I<sub>L</sub>) or larger are available with input option 2. 575V drives up to 150 hp (I<sub>L</sub>) are available with input option 4 (EMC level L). 480V and 690V freestanding drives are available with input option 4 (EMC level L).
- 480V drives up to 30 hp (I<sub>L</sub>) are only available with brake chopper option B. 480V drives 40 hp (I<sub>L</sub>) or larger come standard with brake chopper option N. 230V drives up to 15 hp (I<sub>L</sub>) are only available with brake chopper option B. 230V drives 20 hp and larger come standard with brake chopper option N. All 575V drives come standard without brake chopper option (N). N = No brake chopper.
- 480V drives 250–350 hp (I<sub>L</sub>) and 690V drives 200–300 hp (I<sub>L</sub>) are available with enclosure style 0 (chassis). 480V and 690V FR10 freestanding drives are available with 1 (NEMA Type 1/IP21) or 2 (NEMA Type 12/IP54). FR11 freestanding drives are only available with enclosure style 1 (NEMA Type 1/IP21).
- Factory promise delivery. Consult sales office for availability.

## Product Selection

## 230V Drives

## SPX9000 Open Drives



## 208–240V, NEMA Type 1/IP21 Drives

Frame Size	Delivery Code	hp (I <sub>H</sub> )	Current (I <sub>H</sub> )	hp (I <sub>L</sub> )	Current (I <sub>L</sub> )	Catalog Number
FR4	FP	3/4	3.7	1	4.8	SPXF07A1-2A1B1
		1	4.8	1-1/2	6.6	SPX001A1-2A1B1
		1-1/2	6.6	2	7.8	SPXF15A1-2A1B1
		2	7.8	3	11	SPX002A1-2A1B1
		3	11	—	12.5	SPX003A1-2A1B1
FR5	FP	—	12.5	5	17.5	SPX004A1-2A1B1
		5	17.5	7-1/2	25	SPX005A1-2A1B1
		7-1/2	25	10	31	SPX007A1-2A1B1
FR6	FP	10	31	15	48	SPX010A1-2A1B1
		15	48	20	61	SPX015A1-2A1B1
FR7	FP	20	61	25	75	SPX020A1-2A1N1
		25	75	30	88	SPX025A1-2A1N1
		30	88	40	114	SPX030A1-2A1N1
FR8	FP	40	114	50	140	SPX040A1-2A1N1
		50	140	60	170	SPX050A1-2A1N1
		60	170	75	205	SPX060A1-2A1N1
FR9	FP	75	205	100	261	SPX075A1-2A1N1
		100	261	—	—	SPX100A1-2A1N1

## 208–240V, NEMA Type 12/IP54 Drives

Frame Size	Delivery Code	hp (I <sub>H</sub> )	Current (I <sub>H</sub> )	hp (I <sub>L</sub> )	Current (I <sub>L</sub> )	Catalog Number
FR4	FP	3/4	3.7	1	4.8	SPXF07A2-2A1B1
		1	4.8	1-1/2	6.6	SPX001A2-2A1B1
		1-1/2	6.6	2	7.8	SPXF15A2-2A1B1
		2	7.8	3	11	SPX002A2-2A1B1
		3	11	—	12.5	SPX003A2-2A1B1
FR5	FP	—	12.5	5	17.5	SPX004A2-2A1B1
		5	17.5	7-1/2	25	SPX005A2-2A1B1
		7-1/2	25	10	31	SPX007A2-2A1B1
FR6	FP	10	31	15	48	SPX010A2-2A1B1
		15	48	20	61	SPX015A2-2A1B1
FR7	FP	20	61	25	75	SPX020A2-2A1N1
		25	75	30	88	SPX025A2-2A1N1
		30	88	40	114	SPX030A2-2A1N1
FR8	FP	40	114	50	140	SPX040A2-2A1N1
		50	140	60	170	SPX050A2-2A1N1
		60	170	75	205	SPX060A2-2A1N1
FR9	FP	75	205	100	261	SPX075A2-2A1N1
		100	261	—	—	SPX100A2-2A1N1

# 36.4

## Adjustable Frequency Drives

### SPX9000 Drives

#### 480V Drives

36

#### SPX9000 Open Drives



#### 380–500V, NEMA Type 1/IP21 Drives

Frame Size	Delivery Code	hp (I <sub>H</sub> )	Current (I <sub>H</sub> )	hp (I <sub>L</sub> )	Current (I <sub>L</sub> )	Catalog Number
FR4	W	1	2.2	1-1/2	3.3	SPX001A1-4A1B1
	FP	1-1/2	3.3	2	4.3	SPXF15A1-4A1B1
	FP	2	4.3	3	5.6	SPX002A1-4A1B1
	W	3	5.6	5	7.6	SPX003A1-4A1B1
	W	5	7.6	—	9	SPX005A1-4A1B1
	FP	—	9	7-1/2	12	SPX006A1-4A1B1
FR5	W	7-1/2	12	10	16	SPX007A1-4A1B1
		10	16	15	23	SPX010A1-4A1B1
		15	23	20	31	SPX015A1-4A1B1
FR6	W	20	31	25	38	SPX020A1-4A1B1
		25	38	30	46	SPX025A1-4A1B1
		30	46	40	61	SPX030A1-4A1B1
FR7	FP	40	61	50	72	SPX040A1-4A1N1
	W	50	72	60	87	SPX050A1-4A1N1
	W	60	87	75	105	SPX060A1-4A1N1
FR8	FP	75	105	100	140	SPX075A1-4A1N1
	W	100	140	125	170	SPX100A1-4A1N1
	W	125	170	150	205	SPX125A1-4A1N1
FR9	W	150	205	200	261	SPX150A1-4A1N1
		200	245	250	300	SPX200A1-4A1N1

#### 380–500V, NEMA Type 1/IP21 Freestanding Drives

Frame Size	Delivery Code	hp (I <sub>H</sub> )	Current (I <sub>H</sub> )	hp (I <sub>L</sub> )	Current (I <sub>L</sub> )	Catalog Number
FR10	W	250	330	300	385	SPX250A1-4A4N1
	FP	300	385	350	460	SPX300A1-4A4N1
	W	350	460	400	520	SPX350A1-4A4N1
FR11	FP	400	520	500	590	SPX400A1-4A4N1
	FP	500	590	550	650	SPX500A1-4A4N1
	FP	550	650	600	730	SPX550A1-4A4N1

#### Note

Integrated fuses as standard. Limited option selection available; 115V transformer (KB), light kit (L1), HOA (K4), speed potentiometer w/HOA (K2), Disconnect switch (P2). See Freestanding Option selection on **Page V6-T36-111**.

## SPX9000 Open Drives



## 380–500V, NEMA Type 12/IP54 Drives

Frame Size	Delivery Code	hp (I <sub>H</sub> )	Current (I <sub>H</sub> )	hp (I <sub>L</sub> )	Current (I <sub>L</sub> )	Catalog Number
FR4	W	1	2.2	1-1/2	3.3	SPX001A2-4A1B1
	FP	1-1/2	3.3	2	4.3	SPXF15A2-4A1B1
	FP	2	4.3	3	5.6	SPX002A2-4A1B1
	W	3	5.6	5	7.6	SPX003A2-4A1B1
	W	5	7.6	—	9	SPX005A2-4A1B1
	FP	—	9	7-1/2	12	SPX006A2-4A1B1
FR5	W	7-1/2	12	10	16	SPX007A2-4A1B1
		10	16	15	23	SPX010A2-4A1B1
		15	23	20	31	SPX015A2-4A1B1
FR6	W	20	31	25	38	SPX020A2-4A1B1
		25	38	30	46	SPX025A2-4A1B1
		30	46	40	61	SPX030A2-4A1B1
FR7	FP	40	61	50	72	SPX040A2-4A1N1
		50	72	60	87	SPX050A2-4A1N1
		60	87	75	105	SPX060A2-4A1N1
FR8	FP	75	105	100	140	SPX075A2-4A2N1
		100	140	125	170	SPX100A2-4A1N1
		125	170	150	205	SPX125A2-4A1N1
FR9	FP	150	205	200	261	SPX150A2-4A1N1
		200	245	250	300	SPX200A2-4A1N1

## 380–500V, NEMA Type 12/IP54 Freestanding Drives

Frame Size	Delivery Code	hp (I <sub>H</sub> )	Current (I <sub>H</sub> )	hp (I <sub>L</sub> )	Current (I <sub>L</sub> )	Catalog Number
FR10	FP	250	330	300	385	SPX250A2-4A4N1
	FP	300	385	350	460	SPX300A2-4A4N1
	FP	350	460	400	520	SPX350A2-4A4N1

## 380–500V, Open Chassis Drives

Frame Size <sup>①</sup>	Delivery Code	hp (I <sub>H</sub> )	Current (I <sub>H</sub> )	hp (I <sub>L</sub> )	Current (I <sub>L</sub> )	Catalog Number
FR10	W	250	330	300	385	SPX250A0-4A2N1
		300	385	—	460	SPX300A0-4A2N1
		350	460	400	520	SPX350A0-4A2N1
FR11	FP	400	520	500	590	SPX400A0-4A2N1
		500	590	—	650	SPX500A0-4A2N1
		—	650	600	730	SPX550A0-4A2N1
FR12	FP	600	730	—	820	SPX600A0-4A2N1
		—	820	700	920	SPX650A0-4A2N1
		700	920	800	1030	SPX700A0-4A2N1
FR13	FP	800	1030	900	1150	SPX800A0-4A2N1
		900	1150	1000	1300	SPX900A0-4A2N1
		1000	1300	1200	1450	SPXH10A0-4A2N1
FR14	FP	1200	1600	1500	1770	SPXH12A0-4A2N1
		1600	1940	1800	2150	SPXH16A0-4A2N1

**Notes**

Integrated fuses as standard. Limited option selection available; 115V transformer (KB), light kit (L1), HOA (K4), speed potentiometer w/HOA (K2), disconnect switch (P2). See Freestanding Option selection on [Page V6-T36-111](#).

① FR10–FR14 includes 3% line reactor, but it is not integral to chassis.

# 36.4

## Adjustable Frequency Drives

### SPX9000 Drives

#### 575V Drives

36

#### SPX9000 Open Drives



#### 525–690V, NEMA Type 1/IP21 Drives

Frame Size	Delivery Code	hp (I <sub>H</sub> )	Current (I <sub>H</sub> )	hp (I <sub>L</sub> )	Current (I <sub>L</sub> )	Catalog Number
FR6	W	2	3.3	3	4.5	SPX002A1-5A4N1
		3	4.5	—	5.5	SPX003A1-5A4N1
		—	5.5	5	7.5	SPX004A1-5A4N1
		5	7.5	7-1/2	10	SPX005A1-5A4N1
		7-1/2	10	10	13.5	SPX007A1-5A4N1
		10	13.5	15	18	SPX010A1-5A4N1
		15	18	20	22	SPX015A1-5A4N1
		20	22	25	27	SPX020A1-5A4N1
		25	27	30	34	SPX025A1-5A4N1
FR7	W	30	34	40	41	SPX030A1-5A4N1
		40	41	50	52	SPX040A1-5A4N1
FR8	W	50	52	60	62	SPX050A1-5A4N1
		60	62	75	80	SPX060A1-5A4N1
		75	80	100	100	SPX075A1-5A4N1
FR9	W	100	100	125	125	SPX100A1-5A4N1
		125	125	150	144	SPX125A1-5A4N1
		150	144	—	170	SPX150A1-5A4N1
		—	170	200	208	SPX175A1-5A4N1

#### 525–690V, NEMA Type 1/IP21 Freestanding Drives

Frame Size	Delivery Code	hp (I <sub>H</sub> )	Current (I <sub>H</sub> )	hp (I <sub>L</sub> )	Current (I <sub>L</sub> )	Catalog Number
FR10	FP	200	208	250	261	SPX200A1-5A4N1
		250	261	300	325	SPX250A1-5A4N1
		300	325	400	385	SPX300A1-5A4N1
FR11	FP	400	385	450	460	SPX400A1-5A4N1
		450	460	500	502	SPX450A1-5A4N1
		500	502	550	590	SPX500A1-5A4N1

#### Note

Integrated fuses as standard. Limited option selection available; 115V transformer (KB), light kit (L1), HOA (K4), speed potentiometer w/HOA (K2), disconnect switch (P2). See Freestanding Option selection on **Page V6-T36-111**.



## SPX9000 Open Drives



## 525–690V, NEMA Type 12/IP54 Drives

Frame Size	Delivery Code	hp (I <sub>H</sub> )	Current (I <sub>H</sub> )	hp (I <sub>L</sub> )	Current (I <sub>L</sub> )	Catalog Number
FR6	F1	2	3.3	3	4.5	SPX002A2-5A4N1
		3	4.5	—	5.5	SPX003A2-5A4N1
		—	5.5	5	7.5	SPX004A2-5A4N1
		5	7.5	7-1/2	10	SPX005A2-5A4N1
		7-1/2	10	10	13.5	SPX007A2-5A4N1
		10	13.5	15	18	SPX010A2-5A4N1
		15	18	20	22	SPX015A2-5A4N1
		20	22	25	27	SPX020A2-5A4N1
		25	27	30	34	SPX025A2-5A4N1
FR7	FP	30	34	40	41	SPX030A2-5A4N1
		40	41	50	52	SPX040A2-5A4N1
FR8	FP	50	52	60	62	SPX050A2-5A4N1
		60	62	75	80	SPX060A2-5A4N1
		75	80	100	100	SPX075A2-5A4N1
FR9	FP	100	100	125	125	SPX100A2-5A4N1
		125	125	150	144	SPX125A2-5A4N1
		150	144	—	170	SPX150A2-5A4N1
		—	170	200	208	SPX175A2-5A4N1

## 525–690V, NEMA Type 12/IP54 Freestanding Drives

Frame Size	Delivery Code	hp (I <sub>H</sub> )	Current (I <sub>H</sub> )	hp (I <sub>L</sub> )	Current (I <sub>L</sub> )	Catalog Number
FR10	FP	200	208	250	261	SPX200A2-5A4N1
		250	261	300	325	SPX250A2-5A4N1
		300	325	400	385	SPX300A2-5A4N1

## 525–690V, Open Chassis Drives

Frame Size <sup>①</sup>	Delivery Code	hp (I <sub>H</sub> )	Current (I <sub>H</sub> )	hp (I <sub>L</sub> )	Current (I <sub>L</sub> )	Catalog Number
FR10	FP	200	208	250	261	SPX200A0-5A2N1
		250	261	300	325	SPX250A0-5A2N1
		300	325	400	385	SPX300A0-5A2N1
FR11	FP	400	385	450	460	SPX400A0-5A2N1
		450	460	500	502	SPX450A0-5A2N1
		500	502	—	590	SPX500A0-5A2N1
FR12	FP	—	590	600	650	SPX550A0-5A2N1
		600	650	700	750	SPX600A0-5A2N1
		700	750	800	820	SPX700A0-5A2N1
FR13	FP	800	820	900	920	SPX800A0-5A2N1
		900	920	1000	1030	SPX900A0-5A2N1
		1000	1030	1250	1180	SPXH10A0-5A2N1
FR14	FP	1350	1300	1500	1500	SPXH13A0-5A2N1
		1500	1500	2000	1900	SPXH15A0-5A2N1
		2000	1900	2300	2250	SPXH20A0-5A2N1

**Notes**

Integrated fuses as standard. Limited option selection available; 115V transformer (KB), light kit (L1), HOA (K4), speed potentiometer w/HOA (K2), disconnect switch (P2). See Freestanding Option selection on [Page V6-T36-111](#).

① FR10–FR14 includes 3% line reactor, but it is not integral to chassis.

#### Accessories

36

#### Demo Drive and Power Supply

##### Demo Drive and Power Supply

Description	Catalog Number
9000X demo drive	9000XDEMO
Hand-held 24V auxiliary power supply—Used to supply power to the control module in order to perform keypad programming before the drive is connected to line voltage	9000XAUX24V

#### NEMA Type 12/IP54 Conversion Kit

The NEMA Type 12/IP54 kit option is used to convert a NEMA Type 1/IP21 to a NEMA Type 12/IP54 drive. The NEMA Type 12/IP54 kit consists of a metal drive shroud, fan kit for some frames, adaptor plate and plugs.

##### NEMA Type 12/IP54 Conversion Kit

Frame Size	Delivery Code	Approximate Dimensions in Inches (mm)			Approximate Weight Lb (kg)	Catalog Number
		Length	Width	Height		
FR4	W	13 (330)	7 (178)	4 (102)	4 (1.8)	OPTN12FR4
FR5		16 (406)	8 (203)	7 (178)	5 (2.3)	OPTN12FR5
FR6		21 (533)	10 (254)	5 (127)	7 (3.2)	OPTN12FR6

#### Flange Kits

##### Flange Kit NEMA Type 12/IP54

The flange kit is utilized when the power section is mounted through the back panel of an enclosure. Includes flange mount brackets and NEMA Type 12/IP54 fan components. Metal shroud not included.

Flange kits for NEMA Type 12/IP54 enclosure drive rating are determined by rating of drive.

##### Flange Kit NEMA Type 12/IP54—Frames 4, 5 and 6 <sup>①</sup>

Frame Size	Delivery Code	Catalog Number
FR4	W	OPTTHRFR4
FR5		OPTTHRFR5
FR6		OPTTHRFR6

##### Flange Kit NEMA Type 12/IP54—Frames 4–9 <sup>①</sup>

Frame Size	Delivery Code	Catalog Number
FR4	FP	OPTTHR4
FR5		OPTTHR5
FR6		OPTTHR6
FR7		OPTTHR7
FR8		OPTTHR8
FR9		OPTTHR9

##### Flange Kit NEMA Type 1/IP21

Flange kits for NEMA Type 1/IP21 enclosure drive rating are determined by rating of drive.

##### Flange Kit NEMA Type 1/IP21—Frames 4–9 <sup>①</sup>

Frame Size	Delivery Code	Catalog Number
FR4	FP	OPTTHR4
FR5		OPTTHR5
FR6		OPTTHR6
FR7		OPTTHR7
FR8		OPTTHR8
FR9		OPTTHR9

#### Note

<sup>①</sup> For installation of an SPX9000 NEMA Type 1/IP21 drive into a NEMA Type 12/IP54 oversized enclosure.

## Options

### 9000X Series Option Board Kits

The 9000X Series drives can accommodate a wide selection of expander and adapter option boards to customize the drive for your application needs. The drive's control unit is designed to accept a total of five option boards.

The 9000X Series factory installed standard board configuration includes an A9 I/O board and an A2 relay output board, which are installed in slots A and B.

#### Option Boards

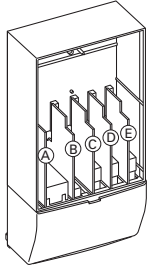

#### Option Board Kits

Option Kit Description <sup>①</sup>	Allowed Slot Locations <sup>②</sup>	Field Installed Catalog Number	Factory Installed Option Designator	SVX Ready Programs						
				Basic	Local/Remote	Standard	MSS	PID	Multi-P.	PFC
<b>Standard I/O Cards</b>										
2 RO (NC-NO)	B	<b>OPTA2</b>	—	■	■	■	■	■	■	■
6 DI, 1 DO, 2 AI, 1AO, 1 +10 Vdc ref, 2 ext +24 Vdc/EXT +24 Vdc	A	<b>OPTA9</b>	—	■	■	■	■	■	■	■
<b>Extended I/O Cards</b>										
2 RO, therm	B	<b>OPTA3</b>	<b>A3</b>	—	■	■	■	■	■	■
Encoder low volt +5V/15V/24V	C	<b>OPTA4</b>	<b>A4</b>	—	■	■	■	■	■	■
Encoder high volt +15V/24V	C	<b>OPTA5</b>	<b>A5</b>	—	■	■	■	■	■	■
Double encoder—SPX only	C	<b>OPTA7</b>	<b>A7</b>	■	■	■	■	■	■	■
6 DI, 1 DO, 2 AI, 1 AO	A	<b>OPTA8</b>	<b>A8</b>	—	■	■	■	■	■	■
6 DI, 1 DO, 2 AI, 1AO, 1 +10 Vdc ref, 2 ext +24 Vdc/EXT +24 Vdc	A	<b>OPTA1</b>	—	■	■	■	■	■	■	■
3 DI (encoder 10–24V), out +15V/+24V, 2 DO (pulse+direction)—SPX only	C	<b>OPTAE</b>	<b>AE</b>	■	■	■	■	■	■	■
6 DI, 1 DO, 2 AI, 1AO, 1 +10 Vdc ref, 2 ext +24 Vdc/EXT +24 Vdc	A	<b>OPTAFA1</b>	—	■	■	■	■	■	■	■
6 DI, 1 ext +24 Vdc/EXT +24 Vdc	B, C, <b>D</b> , E	<b>OPTB1</b>	<b>B1</b>	—	—	—	—	—	■	■
1 RO (NC-NO), 1 RO (NO), 1 therm	B, C, <b>D</b> , E	<b>OPTB2</b>	<b>B2</b>	—	—	—	—	—	■	■
1 AI (mA isolated), 2 AO (mA isolated), 1 ext +24 Vdc/EXT +24 Vdc	B, C, <b>D</b> , E	<b>OPTB4</b>	<b>B4</b>	—	■	■	■	■	■	■
3 RO (NO)	B, C, <b>D</b> , E	<b>OPTB5</b>	<b>B5</b>	—	—	—	—	—	■	■
1 ext +24 Vdc/EXT +24 Vdc, 3 Pt100	B, C, <b>D</b> , E	<b>OPTB8</b>	<b>B8</b>	—	—	—	—	—	—	—
1 RO (NO), 5 DI 42–240 Vac input	B, C, <b>D</b> , E	<b>OPTB9</b>	<b>B9</b>	—	—	—	—	—	■	■
SPI, absolute encoder	C	<b>OPTBB</b>	<b>BB</b>	—	—	—	—	—	—	—

#### Notes

① AI = Analog Input; AO = Analog Output, DI = Digital Input, DO = Digital Output, RO = Relay Output

② Option card must be installed in one of the slots listed for that card. Slot indicated in bold is the preferred location.

#### Option Boards

#### Option Board Kits, continued

36

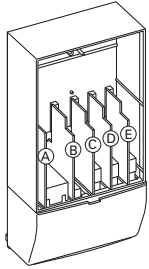

Option Kit Description <sup>①</sup>	Allowed Slot Locations <sup>②</sup>	Field Installed Catalog Number	Factory Installed Option Designator	SVX Ready Programs						
				Basic	Local/Remote	Standard	MSS	PID	Multi-P.	PFC
<b>Communication Cards <sup>③</sup></b>										
Modbus	D, E	<b>OPTC2</b>	<b>C2</b>	■	■	■	■	■	■	■
Johnson Controls N2	D, E	<b>OPTC2</b>	<b>CA</b>	—	—	—	—	—	—	—
Modbus TCP	D, E	<b>OPTCI</b>	<b>CI</b>	■	■	■	■	■	■	■
BACnet	D, E	<b>OPTCJ</b>	<b>CJ</b>	■	■	■	■	■	■	■
Ethernet IP	D, E	<b>OPTCK</b>	<b>CK</b>	■	■	■	■	■	■	■
Profibus DP	D, E	<b>OPTC3</b>	<b>C3</b>	■	■	■	■	■	■	■
LonWorks	D, E	<b>OPTC4</b>	<b>C4</b>	■	■	■	■	■	■	■
Profibus DP (D9 connector)	D, E	<b>OPTC5</b>	<b>C5</b>	■	■	■	■	■	■	■
CanOpen (slave)	D, E	<b>OPTC6</b>	<b>C6</b>	■	■	■	■	■	■	■
DeviceNet	D, E	<b>OPTC7</b>	<b>C7</b>	■	■	■	■	■	■	■
Modbus (D9 type connector)	D, E	<b>OPTC8</b>	<b>C8</b>	■	■	■	■	■	■	■
Adapter—SPX only	D, E	<b>OPTD1</b>	<b>D1</b>	■	■	■	■	■	■	■
Adapter—SPX only	D, E	<b>OPTD2</b>	<b>D2</b>	■	■	■	■	■	■	■
RS-232 with D9 connection	D, E	<b>OPTD3</b>	<b>D3</b>	■	■	■	■	■	■	■
<b>Keypad</b>										
9000X Series local/remote keypad (replacement keypad)	—	<b>KEYPAD-LOC/REM</b>	—	—	—	—	—	—	—	■
9000X Series remote mount keypad unit (keypad not included, includes 10 ft cable, keypad holder, mounting hardware)	—	<b>OPTRMT-KIT-9000X</b>	—	—	—	—	—	—	—	—
9000X Series RS-232 cable, 13 ft	—	<b>PP00104</b>	—	—	—	—	—	—	—	—

#### Notes

- ① AI = Analog Input; AO = Analog Output, DI = Digital Input, DO = Digital Output, RO = Relay Output
- ② Option card must be installed in one of the slots listed for that card. Slot indicated in bold is the preferred location.
- ③ OPTC2 is a multi-protocol option card.

**Modbus RTU Network Communications**

The Modbus Network Card OPTC2 is used for connecting the 9000X Drive as a slave on a Modbus network. The interface is connected by a 9-pin DSUB connector (female) and the baud rate ranges from 300 to 19200 baud. Other communication parameters include an address range from 1 to 247; a parity of None, Odd or Even; and the stop bit is 1.

**PROFIBUS Network Communications**

The PROFIBUS Network Card OPTC3 is used for connecting the 9000X Drive as a slave on a PROFIBUS-DP network. The interface is connected by a 9-pin DSUB connector (female). The baud rates range from 9.6K baud to 12M baud, and the addresses range from 1 to 127.

**LonWorks Network Communications**

The LonWorks Network Card OPTC4 is used for connecting the 9000X Drive on a LonWorks network. This interface uses Standard Network Variable Types (SNVT) as data types. The channel connection is achieved using a FTT-10A Free Topology transceiver via a single twisted transfer cable. The communication speed with LonWorks is 78 kBits/s.

**CANopen (Slave) Communications**

The CANopen (Slave) Network Card OPTC6 is used for connecting the 9000X Drive to a host system. According to ISO11898 standard cables to be chosen for CAN bus should have a nominal impedance of 120 ohms, and specific line delay of nominal 5 nS/m. 120 ohms line termination resistors required for installation.

**DeviceNet Network Communications**

The DeviceNet Network Card OPTC7 is used for connecting the 9000X Drive on a DeviceNet Network. It includes a 5.08 mm pluggable connector. Transfer method is via CAN using a two-wire twisted shielded cable with two-wire bus power cable and drain. The baud rates used for communication include 125K baud, 250K baud and 500K baud.

**Johnson Controls Metasys N2 Network Communications**

The OPTC2 fieldbus board provides communication between the 9000X Drive and a Johnson Controls Metasys™ N2 network. With this connection, the drive can be controlled, monitored and programmed from the Metasys system. The N2 fieldbus is available as a factory installed option and as a field installable kit.

**Modbus/TCP Network Communications**

The Modbus/TCP Network Card OPTCI is used for connecting the 9000X Drive to Ethernet networks utilizing Modbus protocol. It includes an RJ-45 pluggable connector. This interface provides a selection of standard and custom register values to communicate drive parameters. The board supports 10 Mbps and 100 Mbps communication speeds. The IP address of the board is configurable over Ethernet using a supplied software tool.

**BACnet Network Communications**

The BACnet Network Card OPTCJ is used for connecting the 9000X Drive to BACnet networks. It includes a 5.08 mm pluggable connector. Data transfer is Master-Slave/Token Passing (MS/TP) RS-485. This interface uses a collection of 30 Binary Value Objects (BVOs) and 35 Analog Value Objects (AVOs) to communicate drive parameters. The card supports 9.6, 19.2 and 38.4 Kbaud communication speeds and supports network addresses 1–127.

**Ethernet/IP Network Communications**

The Ethernet/IP Network Card OPTCK is used for connecting the 9000X Drive to Ethernet/Industrial Protocol networks. It includes an RJ-45 pluggable connector. The interface uses CIP objects to communicate drive parameters (CIP is "Common Industrial Protocol", the same protocol used by DeviceNet). The board supports 10 Mbps and 100 Mbps communication speeds. The IP address of the board is configurable by Static, BOOTP and DHCP methods.

# 36.4

## Adjustable Frequency Drives

### SPX9000 Drives

#### Control Panel Options

##### Factory Options

Description	Factory Installed Option Code	Field Installed NEMA Type 1/IP21 Catalog Number
<b>Local/Remote Keypad SVX9000 Control Panel</b> —This option is standard on all drives and consists of an RS-232 connection, backlit alphanumeric LCD display with nine indicators for the RUN status and two indicators for the control source. The nine pushbuttons on the panel are used for panel programming and monitoring of all SVX9000 parameters. The panel is detachable and isolated from the input line potential. Include LOC/REM key to choose control location.	<b>A</b>	<b>KEYPAD-LOC/REM</b>
<b>Keypad Remote Mounting Kit</b> —This option is used to remote mount the SVX9000 keypad. The footprint is compatible to the SV9000 remote mount kit. Includes 10 ft cable, keypad holder and mounting hardware.	—	<b>OPTRMT-KIT-9000X</b>
<b>Keypad Blank</b> —9000X Series select keypad for use with special and custom applications.	—	<b>KEYPAD-BLANK</b>

##### Miscellaneous Options

Description	Catalog Number
<b>9000XDrive</b> —A PC-based tool for controlling and monitoring of the SVX9000. Features include: loading parameters that can be saved to a file or printed, setting references, starting and stopping the motor, monitoring signals in graphical or text form, and real-time display. To avoid damage to the drive or computer, SVDrivecable must be used.	<b>9000XDRIVE</b>
<b>SVDrivecable</b> —6 ft (1.8m) RS-232 cable (22 gauge) with a 7-pin connector on each end. Should be used in conjunction with the 9000XDrive option to avoid damage to the SVX9000 or computer. The same cable can be used for downloading specialized applications to the drive.	<b>SVDRIVECABLE</b>
<b>External Dynamic Braking Resistors</b> —Used with the dynamic braking chopper circuit to absorb motor regenerative energy for stopping the load and to dissipate the energy flowing back into the drive. Resistors are separated into standard duty and heavy-duty. Standard duty is defined as 20% duty or less with 100% braking torque, while heavy-duty is defined as 50% duty or less with 150% braking torque.	①

#### SPX9000 Drive Options

##### Brake Chopper Options

The brake chopper circuit option is used for applications that require dynamic braking. Dynamic braking resistors are not included with drive

purchase. Consult the factory for dynamic braking resistors which are supplied separately. Resistors are not UL Listed.

For brake chopper circuit selection and adder—NEMA Type 1/IP21, NEMA Type 12/IP54, Chassis, consult the factory. Delivery code is FP.

##### Conformal (Varnished) Coating ②

Chassis Frame	Delivery Code
FR4	FP
FR5	FP
FR6	FP
FR7	FP
FR8	FP
FR9	FP
FR10	FP
FR11	FP
FR12	FP
FR13	FP
FR14	FP

##### Conformal Coated Board Kits ③

Field Installed Catalog Number	Factory Installed Option Designator
<b>OPT_V</b> ④	⑤

##### Notes

- ① Consult factory.
- ② See Product Selection on **Pages V6-T36-101 to V6-T36-105**, 208–240V, 380–500V, 525–690V. Consult the factory for adder
- ③ See option catalog numbers on **Page V6-T36-107**.
- ④ Replace “\_” with the correct catalog number from **Page V6-T36-107**. Example: OPTC2V.
- ⑤ Construct catalog numbers for factory installed per Catalog Number Selection on **Page V6-T36-100**.

**Control/Communication Options****Available Control/Communications Options**

Option	Description	Option Type
<b>K2</b>	<b>Door-Mounted Speed Potentiometer with HOA Selector Switch</b> —Provides the SPX9000 with the ability to start/stop and adjust the speed reference from door-mounted control devices or remotely from customer supplied inputs. In HAND position, the drive will start and the speed is controlled by the door-mounted speed potentiometer. The drive will be disabled in the OFF position. When AUTO is selected, the drive run and speed control commands are via user-supplied dry contact and 4–20 mA signal.	Control
<b>K4</b>	<b>HAND/OFF/AUTO Switch for Non-Bypass Configurations</b> —Provides a three-position selector switch that allows the user to select either a HAND or AUTO mode of operation. HAND mode is defaulted to keypad operation, and AUTO mode is defaulted to control from an external terminal source. These modes of operation can be configured via programming to allow for alternate combinations of start and speed sources. Start and speed sources include keypad, I/O and fieldbus.	Control
<b>KB</b>	<b>115V Control Transformer, 550 VA</b> —Provides a fused control power transformer with additional 550 VA at 115V for customer use.	Control
<b>L1</b>	<b>Power On and Fault Pilot Lights</b> —Provide a white power on light that indicates power to the enclosed cabinet and a red fault light that indicates a drive fault has occurred.	Light
<b>P2</b>	<b>Disconnect Switch</b> —Disconnect switch option is applicable only with NEMA Type 1/IP21 and NEMA Type 12/IP54 Freestanding drives. Allows a convenient means of disconnecting the SPX9000 from the line, and the operating mechanism can be padlocked in the OFF position. This is factory-mounted in the enclosure.	Input

**SPX Freestanding Options****480V and 690V Control Options, 200–550 hp** ①

Description	Catalog Number Suffix
Door-mounted speed potentiometer with HOA selector switch	<b>K2</b>
HAND/OFF/AUTO switch (22 mm)	<b>K4</b>
115 volt control transformer 550 VA	<b>KB</b>

**480V and 690V Light Options, 200–550 hp** ①

Description	Catalog Number Suffix
Power on/fault pilot lights	<b>L1</b>

**Input Options, 200–550 hp** ①

Description	Catalog Number Suffix
Disconnect switch	<b>P2</b> ②

**Notes**

① Consult factory for adder information.

② Applicable with FR10 and FR11 freestanding designs only.

# 36.4

## Adjustable Frequency Drives

### SPX9000 Drives

#### Replacement Parts

36

#### SPX9000 Drives Spare Units

##### 208–690V, Frames 4–12

###### Description

Control unit—Includes the control board, blue base housing, installed SVX9000 software program and blue flip cover. Does not include any OPT boards or keypad. See **Page V6-T36-107** for standard and option boards and keypad.

###### Catalog Number

CSBS000000000

#### SPX9000 Drives Replacement Parts

##### 208–240V, Frames FR4–FR8

Frame	4				5				6				7				8				Delivery Code	Catalog Number
hp (I <sub>H</sub> ):	3/4	1	1-1/2	2	3	5 <sup>①</sup>	5	7-1/2	10	15	20	25	30	40	50	60						
<b>Control Board</b>																						
	1	1	1	1	1	1	1	1	1	1	1	1	1	1	1	1	1	1	1	W	VB00561	
<b>Power Boards</b>																						
	1																			FB	VB00308-0004-2	
		1																		FB	VB00308-0007-2	
			1																	FB	VB00308-0008-2	
				1																FB	VB00310-0011-2	
					1															FB	VB00310-0012-2	
						1														FB	VB00313-0017-2	
							1													FB	VB00313-0025-2	
								1												FB	VB00313-0031-2	
									1											FB	VB00316-0048-2	
										1										FB	VB00316-0061-2	
											1									FB	VB00319-0075-2	
												1								FB	VB00319-0088-2	
													1							FB	VB00319-0114-2	
														1						FB	VB00322-0140-2	
															1					FB	VB00322-0170-2	
																1				FB	VB00322-0205-2	
<b>Electrolytic Capacitors</b>																						
	2	2	2																	W	PP01000	
				2	2															W	PP01001	
						2	2													W	PP01002	
								2												W	PP01003	
									2	2										W	PP01004	
											2	2								W	PP01005	
																				W	PP01099	

#### Note

① I<sub>L</sub> only; has no corresponding I<sub>H</sub> rated hp rating.



## 208–240V, Frames FR4–FR8, continued

Frame	4		5		6		7		8			Delivery Code	Catalog Number					
hp (I <sub>H</sub> ):	3/4	1	1-1/2	2	3	5 <sup>①</sup>	5	7-1/2	10	15	20			25	30	40	50	60
<b>Cooling Fans</b>																		
	1	1	1	1	1												W	PP01060
						1	1	1									W	PP01061
									1	1							W	PP01062
											1	1	1				W	PP01063
														1	1	1	FC	PP01123 <sup>②</sup>
	1	1	1	1	1												W	PP01086
						1	1	1	1	1							FC	PP01088
											1	1	1				W	PP01049
														1	2	2	FC	CP01180
														1	1	1	FC	PP08037
<b>IGBT Modules</b>																		
	1	1															W	CP01304
			1														W	CP01305
				1	1	1											W	CP01306
							1										W	CP01307
								1									W	CP01308
									1								W	PP01022
										1							W	PP01023
											1						W	PP01024
												1					W	PP01025
													1				W	PP01029
														1			W	PP01026
															1	1	W	PP01027
<b>Choppers/Rectifiers</b>																		
									1								W	CP01367
										1							W	CP01368
<b>Diode/Thyristor Modules</b>																		
											3	3	3				W	PP01035
														3	3	3	W	CP01268
<b>Rectifying Boards</b>																		
											1	1	1				W	VB00242
														1	1	1	W	VB00227

**Note**

② PP00061 capacitor not included in main fan; please order separately.

# 36.4

## Adjustable Frequency Drives

### SPX9000 Drives

36

#### 380–500V, Frames FR4–FR9

Frame	4			5			6			7			8			9			Delivery Code	Catalog Number			
hp (I <sub>R</sub> ):	1	1-1/2	2	3	5	7-1/2 <sup>①</sup>	7-1/2	10	15	20	25	30	40	50	60	75	100	125	150	200			
<b>Control Board</b>																							
	1	1	1	1	1	1	1	1	1	1	1	1	1	1	1	1	1	1	1	1	1	W	VB00252
<b>Power Boards</b>																							
	1																					FB	VB00208-0003-5
		1																				FB	VB00208-0004-5
			1																			FB	VB00208-0005-5
				1																		FB	VB00208-0007-5
					1																	FB	VB00208-0009-5
						1																FB	VB00210-0012-5
							1															FB	VB00213-0016-5
								1														FB	VB00213-0022-5
									1													FB	VB00213-0031-5
										1												FB	VB00216-0038-5
											1											FB	VB00216-0045-5
												1										FB	VB00216-0061-5
													1									FB	VB00219-0072-5
														1								FB	VB00219-0087-5
															1							FB	VB00219-0105-5
																1						FB	VB00236-0140-5
																	1					FB	VB00236-0168-5
																		1				FB	VB00236-0205-5
<b>Electrolytic Capacitors</b>																							
	2	2	2	2																		W	PP01000
					2	2																W	PP01001
							2	2														W	PP01002
									2													W	PP01003
										2	2	2										W	PP01004
													2	2	2	4	4	4	8	8		W	PP01005
<b>Cooling Fans</b>																							
	1	1	1	1	1	1																W	PP01060
							1	1	1													W	PP01061
										1	1	1										W	PP01062
													1	1	1							W	PP01063
																1	1	1				FC	PP01123 <sup>②</sup>
																			1	1		FC	PP01080 <sup>③</sup>
	1	1	1	1	1	1																W	PP01086
							1	1	1													FC	PP01088
										1	1	1	1	1	1							W	PP01049
																1	1	1				FC	CP01180
																				1 <sup>④</sup>	2	W	PP01068
																				1	1	FC	PP09051

**Notes**

- ① I<sub>L</sub> only; has no corresponding I<sub>R</sub> rated hp rating.
- ② PP00061 capacitor not included in main fan; please order separately.
- ③ PP00011 capacitor not included in main fan; please order separately.
- ④ For FR9 NEMA Type 12/IP54 you need two PP01068 internal fans.

## 380–500V, Frames FR4–FR9, continued

Frame	4			5			6			7			8			9			Delivery Code	Catalog Number		
hp (I <sub>H</sub> ):	1	1-1/2	2	3	5	7-1/2 <sup>①</sup>	7-1/2	10	15	20	25	30	40	50	60	75	100	125	150	200		
<b>IGBT Modules</b>																						
	1	1	1																		W	CP01304
				1	1																W	CP01305
						1	1														W	CP01306
								1													W	CP01307
									1												W	CP01308
										1	1										W	PP01022
												1									W	PP01023
													1								W	PP01024
														1							W	PP01025
															1						W	PP01029
																1					W	PP01026
																	1	1			W	PP01027
<b>Chopper/Rectifiers</b>																						
										1	1										W	CP01367
												1									W	CP01368
<b>Diode/Thyristor Modules</b>																						
												3	3	3							W	PP01035
															3	3	3				W	CP01268
																		3	3		W	PP01037
<b>Rectifying Boards</b>																						
												1	1	1							W	VB00242
															1	1	1				W	VB00227
																		1	1		W	VB00459
<b>Rectifying Module Sub-assembly</b>																						
																			1	1	W	FR09810
<b>Power Module Sub-assemblies</b>																						
																			1		W	FR09-150-4-ANS <sup>②</sup>
																				1	W	FR09-200-4-ANS <sup>②</sup>

**Notes**

- ① I<sub>L</sub> only; has no corresponding I<sub>H</sub> rated hp rating.  
 ② See Page V6-T36-100 for details.

# 36.4

## Adjustable Frequency Drives

### SPX9000 Drives

#### 380–500V, Frames FR10–FR12

Frame	10		11			12			Delivery Code	Catalog Number	
hp (H):	250	300	350	400	500	550	600	650	700		
<b>Control Board</b>											
1	1		1	1	1	1	1	1	1	W	VB00561
<b>Shunt Boards</b>											
6										FC	VB00537
	6									FC	VB00497
		6					12	12	12	FC	VB00498
			9							FC	VB00538
				9						FC	VB00513
					9					FC	VB00514
<b>Driver Boards</b>											
			3	3	3					FC	VB00489
1	1	1					2	2	2	FC	VB00487
<b>Driver Adapter Board</b>											
1	1	1					2	2	2	FC	VB00330
<b>ASIC Board</b>											
1	1	1	1	1	1	1	2	2	2	FC	VB00451
<b>Feedback Interface Board</b>											
							2	2	2	FC	VB00448
<b>Star Coupler Board</b>											
							1	1	1	FC	VB00336
<b>Power Modules</b>											
1	1	1	2	2	2	2	2	2	2	FC	FR10820 <sup>①</sup>
2	2	2								FC	FR10828
1										FC	FR10-250-4-ANS <sup>②</sup>
	1									FC	FR10-300-4-ANS <sup>②</sup>
		1					2	2	2	FC	FR10-350-4-ANS <sup>②</sup>
			3							FC	FR11-400-4-ANS <sup>②</sup>
				3						FC	FR11-500-4-ANS <sup>②</sup>
					3					FC	FR11-550-4-ANS <sup>②</sup>
<b>Electrolytic Capacitors</b>											
2	2	2	3	3	3	3	4	4	4	FC	PP00060
12	12	12	18	18	18	18	24	24	24	FC	PP01005
<b>Fuses</b>											
1	1	1	1	1	1	1	2	2	2	FC	PP01094
2	2	2	2	2	2	2	4	4	4	FC	PP01095
<b>Cooling Fans and Isolation Transformers</b>											
2	2	2	3	3	3	3	4	4	4	FC	VB00299
2	2	2	3	3	3	3	4	4	4	FC	PP01080 <sup>③</sup>
2	2	2					4	4	4	FC	PP01068
1	1	1	1	1	1	1	2	2	2	FC	PP01096
1	1	1					2	2	2	FC	FR10844
1	1	1	3	3	3	3	2	2	2	FC	FR10845
1	1	1					2	2	2	FC	FR10846
1	1	1	3	3	3	3	2	2	2	FC	FR10847
<b>Rectifying Board</b>											
1	1	1	2	2	2	2	2	2	2	FC	VB00459

#### Notes

- ① Rectifying board not included.
- ② See Page V6-T36-100 for details.
- ③ PP00060 capacitor not included in main fan; please order separately.

## 525–690V, Frames FR6–FR9

Frame	6		7							8		9					Delivery Code	Catalog Number		
hp (I <sub>H</sub> ):	2	3	5 <sup>①</sup>	5	7-1/2	10	15	20	25	30	40	50	60	75	100	125	150	200 <sup>①</sup>		
<b>Control Board</b>																				
	1	1	1	1	1	1	1	1	1	1	1				1	1	1	W	VB00561	
<b>Driver Boards</b>																				
	1																	FB	VB00404-0004-6	
		1																FB	VB00404-0005-6	
			1															FB	VB00404-0007-6	
				1														FB	VB00404-0010-6	
					1													FB	VB00404-0013-6	
						1												FB	VB00404-0018-6	
							1											FB	VB00404-0022-6	
								1										FB	VB00404-0027-6	
									1									FB	VB00404-0034-6	
<b>Power Boards</b>																				
	1	1	1	1	1	1	1	1	1									FB	VB00414	
										1								FB	VB00419-0041-6	
											1							FB	VB00419-0052-6	
												1						FB	VB00422-0062-6	
													1					FB	VB00422-0080-6	
														1				FB	VB00422-0100-6	
<b>Power Modules</b>																				
														1				FC	FR09-100-5-ANS <sup>②</sup>	
															1			FC	FR09-125-5-ANS <sup>②</sup>	
																1		FC	FR09-150-5-ANS <sup>②</sup>	
																	1	FC	FR09-175-5-ANS <sup>②</sup>	
<b>Electrolytic Capacitors</b>																				
	2	2	2	2	2	2	2	2	2									FC	PP01093	
										2	2	4	4		8	8	8	8	FC	PP01041
													4					FC	PP01040	
<b>Fuses</b>																				
											1	1	1	1	1	1	1	W	PP01094	
											2	2	2	2	2	2	2	W	PP01095	

**Notes**

- ① I<sub>L</sub> only; has no corresponding I<sub>H</sub> rated hp rating.  
 ② See Page V6-T36-100 for details.

# 36.4

## Adjustable Frequency Drives

### SPX9000 Drives

#### 525–690V, Frames FR6–FR9, continued

Frame	6						7				8		9				Delivery Code	Catalog Number		
hp (I <sub>H</sub> ):	2	3	5 <sup>①</sup>	5	7-1/2	10	15	20	25	30	40	50	60	75	100	125	150	200 <sup>①</sup>		
<b>Cooling Fans</b>																				
	1	1	1	1	1														W	PP01061
						1	1	1	1										W	PP01062
										1	1								W	PP01063
												1	1	1					FC	PP01123
	1	1	1	1	1	1	1	1	1	1	1								W	PP01049
												1	1	1					FC	CP01180
															1	1	1	1 <sup>②</sup>	W	PP01068
															1	1	1	1	FC	PP01080
<b>Fan Power Supply</b>																				
																1	1	1	FC	VB00299
<b>IGBT Modules</b>																				
	3	3	3	3	3	3	3	3	3										FC	PP01091
										1	1								FC	PP01089
												1	1	1					FC	PP01127
<b>IGBT/Diode (Brake)</b>																				
	1	1	1	1	1	1	1	1	1	1	1	2	2	2	2	2	2	2	FC	PP01040
<b>Diode Module</b>																				
	1	1	1	1	1	1	1	1	1										FC	PP01092
<b>Diode/Thyristor Modules</b>																				
										3	3								FC	PP01071
															3	3	3	3	FC	PP01072
<b>Rectifying Boards</b>																				
										1	1								FC	VB00442
															1	1	1	1	FC	VB00460
<b>Rectifying Module Sub-Assemblies</b>																				
																1	1	1	W	FR09810
																1	1	1	FC	FR09811

**Notes**

- ① I<sub>L</sub> only; has no corresponding I<sub>H</sub> rated hp rating.
- ② For NEMA Type 12/IP54, two PP01068 internal fans are needed.

## 525–690V, Frames FR10–FR12

Frame hp (I <sub>H</sub> ):	10 250	300	350	11 400	500	550	12 600	650	700	Delivery Code	Catalog Number
<b>Component Boards</b>											
	1	1	1	1	1	1	1	1	1	W	VB00561
	1	1	1	1	1	1	2	2	2	FC	VB00451
	6									FC	VB00545
		6								FC	VB00510
			6				12	12	12	FC	VB00511
	1	1	1				2	2	2	FC	VB00330
	1	1	1				2	2	2	FC	VB00487
				3	3	3				FC	VB00489
				9						FC	VB00546
					9					FC	VB00547
						9				FC	VB00512
							2	2	2	FC	VB00448
							1	1	1	FC	VB00336
<b>Power Modules</b>											
	1	1	1	2	2	2	2	2	2	FC	FR10821 <sup>①</sup>
	2	2	2							FC	FR10829
	1									FC	FR10-200-5-ANS <sup>②</sup>
		1								FC	FR10-250-5-ANS <sup>②</sup>
			1				2	2	2	FC	FR10-300-5-ANS <sup>②</sup>
				3						FC	FR11-400-5-ANS <sup>②</sup>
					3					FC	FR11-450-5-ANS <sup>②</sup>
						3				FC	FR11-500-5-ANS <sup>②</sup>
<b>Electrolytic Capacitors</b>											
	2	2	2	3	3	3	4	4	4	FC	PP00060
	12	12	12	18	18	18	24	24	24	FC	PP01099
<b>Fuses</b>											
	1	1	1	1	1	1	2	2	2	FC	PP01094
	2	2	2	2	2	2	4	4	4	FC	PP01095
<b>Cooling Fans and Isolation Transformers</b>											
	2	2	2	3	3	3	4	4	4	FC	VB00299
	2	2	2	3	3	3	4	4	4	FC	PP01080 <sup>③</sup>
	2	2	2				4	4	4	FC	PP01068
	1	1	1	1	1	1	2	2	2	FC	PP01096
	1	1	1				2	2	2	FC	FR10844
	1	1	1	3	3	3	2	2	2	FC	FR10845
	1	1	1				2	2	2	FC	FR10846
	1	1	1	3	3	3	2	2	2	FC	FR10847
<b>Fan Power Supply</b>											
							1	1	1	FC	VB00299
<b>Rectifying Boards</b>											
	1	1	1	2	2	2	2	2	2	FC	VB00460

**Notes**

- ① Rectifying board not included.  
 ② See **Page V6-T36-100** for details.  
 ③ PP00060 capacitor not included in main fan; please order separately.

## Technical Data and Specifications

### SPX9000 Drives

Description	Specification
<b>Input Ratings</b>	
Input voltage ( $V_{in}$ )	+10%/–15%
Input frequency ( $f_{in}$ )	50/60 Hz (variation up to 45–66 Hz)
Connection to power	Once per minute or less (typical operation)
High withstand rating	100 kAIC
<b>Output Ratings</b>	
Output voltage	0 to $V_{in}$
Continuous output current	$I_H$ rated 100% at 122°F (50°C), FR9 and below $I_L$ rated 100% at 104°F (40°C), FR9 and below $I_H/I_L$ 100% at 104°F (40°C), FR10 and above
Overload current ( $I_H/I_L$ )	150% $I_H$ , 110% $I_L$ for 1 min.
Output frequency	0 to 320 Hz
Frequency resolution	0.01 Hz
Initial output current ( $I_H$ )	250% for 2 seconds
<b>Control Characteristics</b>	
Control method	Frequency control (V/f) Open loop: sensorless vector control Closed loop: frequency control Closed loop: vector control
Switching frequency	Adjustable with parameter 2.6.9
Frame 4–6	1 to 16 kHz; default 10 kHz
Frame 7–12	1 to 10 kHz; default 3.6 kHz
Frequency reference	Analog input: Resolution 0.1% (10-bit), accuracy $\pm 1\%$ V/Hz Panel reference: Resolution 0.01 Hz
Field weakening point	30 to 320 Hz
Acceleration time	0 to 3000 sec.
Deceleration time	0 to 3000 sec.
Braking torque	DC brake: 30% $\times T_n$ (without brake option)
<b>Ambient Conditions</b>	
Ambient operating temperature	14°F (–10°C), no frost to 122°F (50°C) $I_H$ (FR4–FR9) 14°F (–10°C), no frost to 104°F (40°C) $I_L$ (FR10 and up) 14°F (–10°C), no frost to 104°F (40°C) $I_L$ (all frames)
Storage temperature	–40° to 158°F (–40° to 70°C)
Relative humidity	0 to 95% RH, noncondensing, non-corrosive, no dripping water
Air quality	Chemical vapors: IEC 721-3-3, unit in operation, class 3C2; Mechanical particles: IEC 721-3-3, unit in operation, class 3S2
Altitude	100% load capacity (no derating) up to 3280 ft (1000m); 1% derating for each 328 ft (100m) above 3280 ft (1000m); max. 9842 ft (3000m)
Vibration	EN 50178, EN 60068-2-6; 5 to 50 Hz, displacement amplitude 1 mm (peak) at 3 to 15.8 Hz, max. acceleration amplitude 1G at 15.8 to 150 Hz
Shock	EN 50178, EN 60068-2-27 UPS Drop test (for applicable UPS weights) Storage and shipping: max. 15G, 11 ms (in package)
Enclosure class	NEMA 1/IP21 or NEMA 12/IP54, open chassis/IP20

Description	Specification
<b>Control Connections</b>	
Analog input voltage	0 to 10V, R = 200 kohms (–10 to 10V joystick control) resolution 0.1%; accuracy $\pm 1\%$
Analog input current	0(4) to 20 mA; $R_i$ —250 ohms differential
Digital inputs (6)	Positive or negative logic; 18 to 30 Vdc
Auxiliary voltage	+24V $\pm 15\%$ , max. 250 mA
Output reference voltage	+10V +3%, max. load 10 mA
Analog output	0(4) to 20 mA; $R_L$ max. 500 ohms; resolution 10 bit; Accuracy $\pm 2\%$
Digital outputs	Open collector output, 50 mA/48V
Relay outputs	2 programmable Form C relay outputs switching capacity: 24 Vdc/8A, 250 Vac/8A, 125 Vdc/0.4A
<b>Protections</b>	
Overcurrent protection	Trip limit 4.0 $\times I_H$ instantaneously
Overvoltage protection	Yes
Undervoltage protection	Yes
Earth fault protection	In case of earth fault in motor or motor cable, only the frequency converter is protected
Input phase supervision	Trips if any of the input phases are missing
Motor phase supervision	Trips if any of the output phases are missing
Overtemperature protection	Yes
Motor overload protection	Yes
Motor stall protection	Yes
Motor underload protection	Yes
Short circuit protection	Yes (+24V and +10V reference voltages)
<b>High Performance Features</b>	
Speed error	<0.01%, depending on the encoder
Encoder support	Incremental or absolute
Encoder voltages	5V (RS-422), 15V or 24V, depending on the option card
Torque control	Full torque control at all speeds, including zero
Torque accuracy	<2%; <5% down to zero speed
Starting torque	>200%, depending on motor and drive sizing
Master/slave configurations	Full capability
System analysis	Integrated data logger
PC communication	Fast multiple drive monitoring with PC
Inter-drive communication	High-speed bus (12 Mbits/s)
High-speed applications	Up to 7200 Hz



## Dimensions

Approximate Dimensions in Inches (mm)

### 9000X Drives

#### NEMA Type 1/IP21 and NEMA Type 12/IP54, FR4, FR5 and FR6

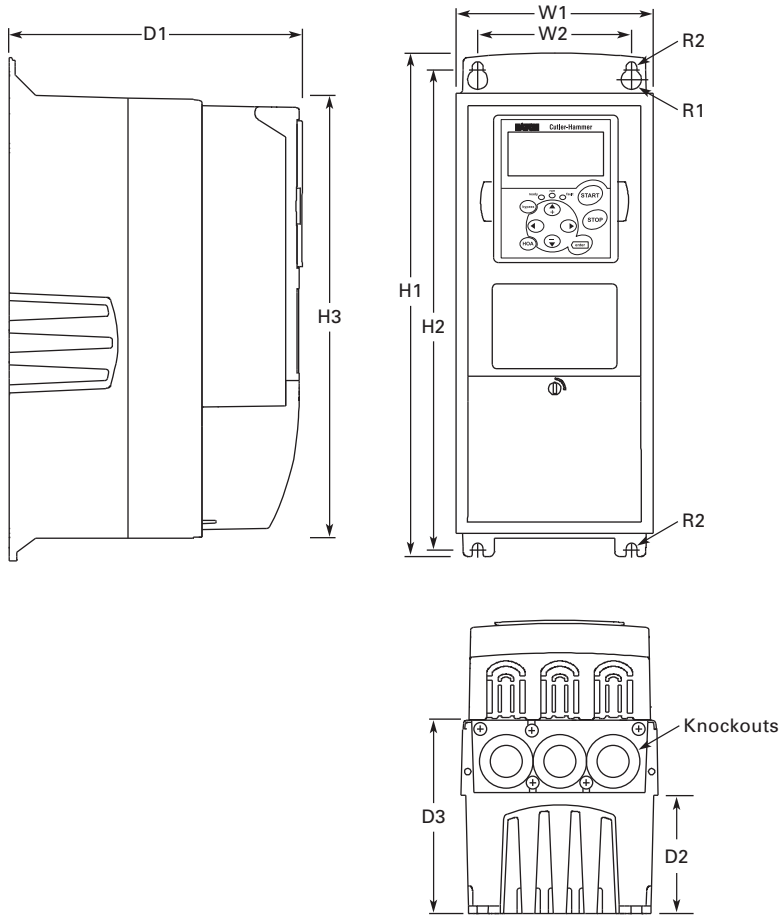

Voltage	hp (I <sub>H</sub> )	H1	H2	H3	D1	D2	D3	W1	W2	R1 Dia.	R2 Dia.	Weight Lbs (kg)	Knockouts at Inches (mm) N1 (O.D.)
<b>FR4</b>													
230V	3/4–3	12.9	12.3	11.5	7.5	3.0	5.0	5.04	3.9	0.5	0.3	11.0 (5)	3 at 10.1 (28)
480V	1–5	(327)	(313)	(292)	(190)	(77)	(126)	(128)	(100)	(13)	(7)		
<b>FR5</b>													
230V	5–7-1/2	16.5	16.0	15.3	8.4	3.9	5.8	5.7	3.9	0.5	0.3	17.9 (8)	2 at 1.5 (37)
480V	7-1/2–15	(419)	(406)	(389)	(214)	(100)	(148)	(144)	(100)	(13)	(7)		1 at 10.1 (28)
<b>FR6</b>													
230V	10–15	22.0	21.3	20.4	9.3	4.2	6.5	7.7	5.8	0.6	0.4	40.8 (19)	3 at 1.5 (37)
480V	20–30	(558)	(541)	(519)	(237)	(105)	(165)	(195)	(148)	(15.5)	(9)		
575V	2–25												

# 36.4 Adjustable Frequency Drives

## SPX9000 Drives

Approximate Dimensions in Inches (mm)

### NEMA Type 1/IP21 and NEMA Type 12/IP54 with Flange Kit, FR4, FR5 and FR6

36

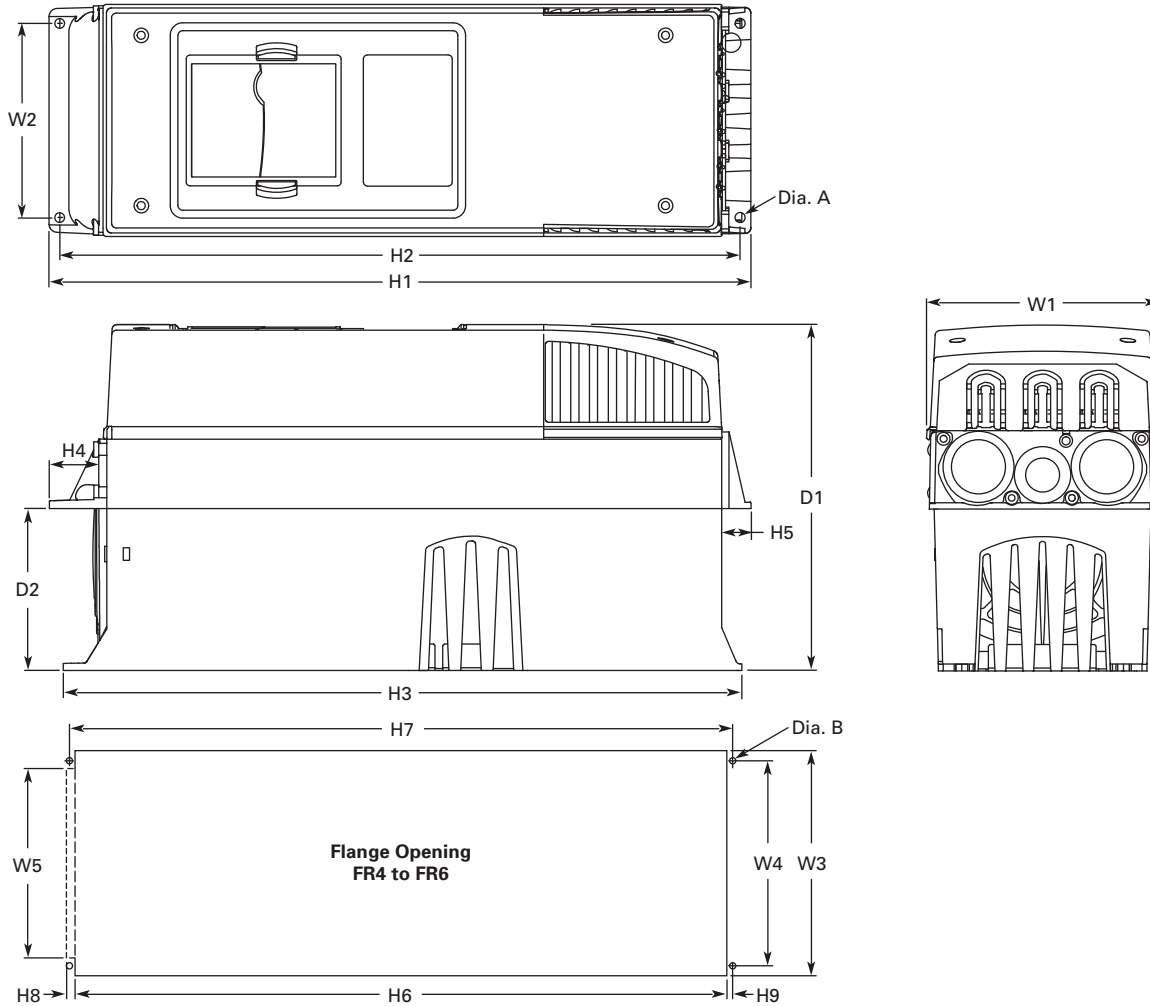

#### FR4, FR5 and FR6 with Flange Kit

W1	W2	H1	H2	H3	H4	H5	D1	D2	Dia. A
<b>FR4</b>									
5.0 (128)	4.5 (113)	13.3 (337)	12.8 (325)	12.9 (327)	1.2 (30)	0.9 (22)	7.5 (190)	3.0 (77)	0.3 (7)
<b>FR5</b>									
5.6 (143)	4.7 (120)	17.0 (434)	16.5 (420)	16.5 (419)	1.4 (36)	0.7 (18)	8.4 (214)	3.9 (100)	0.3 (7)
<b>FR6</b>									
7.7 (195)	6.7 (170)	22.0 (560)	21.6 (549)	22.0 (558)	1.2 (30)	0.8 (20)	9.3 (237)	4.2 (106)	0.3 (7)

#### Flange Opening, FR4 to FR6

W3	W4	W5	H6	H7	H8	H9	Dia. B
<b>FR4</b>							
4.8 (123)	4.5 (113)	—	12.4 (315)	12.8 (325)	—	0.2 (5)	0.3 (7)
<b>FR5</b>							
5.3 (135)	4.7 (120)	—	16.2 (410)	16.5 (420)	—	0.2 (5)	0.3 (7)
<b>FR6</b>							
7.3 (185)	6.7 (170)	6.2 (157)	21.2 (539)	21.6 (549)	0.3 (7)	0.2 (5)	0.3 (7)

Approximate Dimensions in Inches (mm)

NEMA Type 1/IP21 and NEMA Type 12/IP54, FR7

36

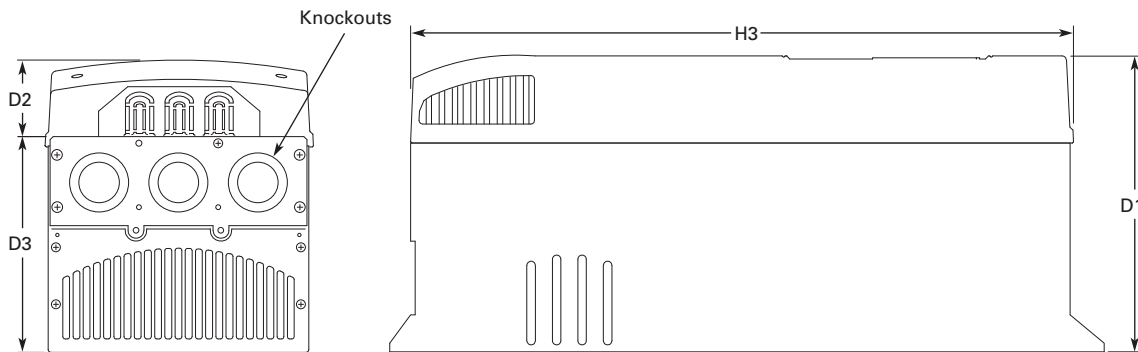
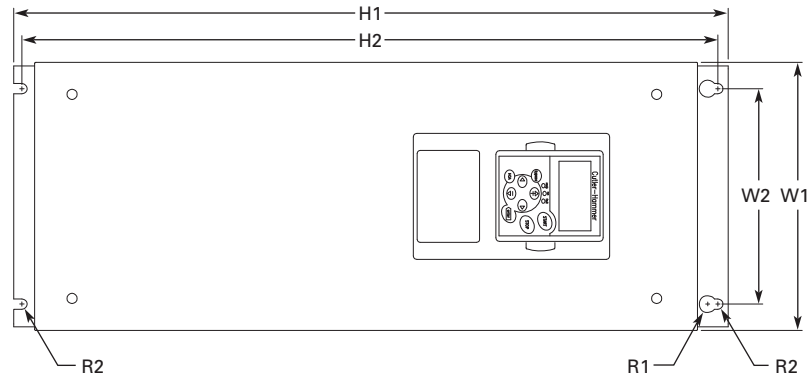

Voltage	hp (I <sub>H</sub> )	H1	H2	H3	D1	D2	D3	W1	W2	R1 Dia.	R2 Dia.	Weight Lbs (kg)	Knockouts at Inches (mm) N1 (O.D.)
230V	20–30	24.8 (630)	24.2 (614)	23.2 (590)	10.1 (257)	3.0 (77)	7.3 (184)	9.3 (237)	7.5 (190)	0.7 (18)	0.4 (9)	77.2 (35)	3 at 1.5 (37)
480V	40–60												
575V	30–40												

# 36.4 Adjustable Frequency Drives

SPX9000 Drives

Approximate Dimensions in Inches (mm)

NEMA Type 1/IP21 and NEMA Type 12/IP54, FR8

36

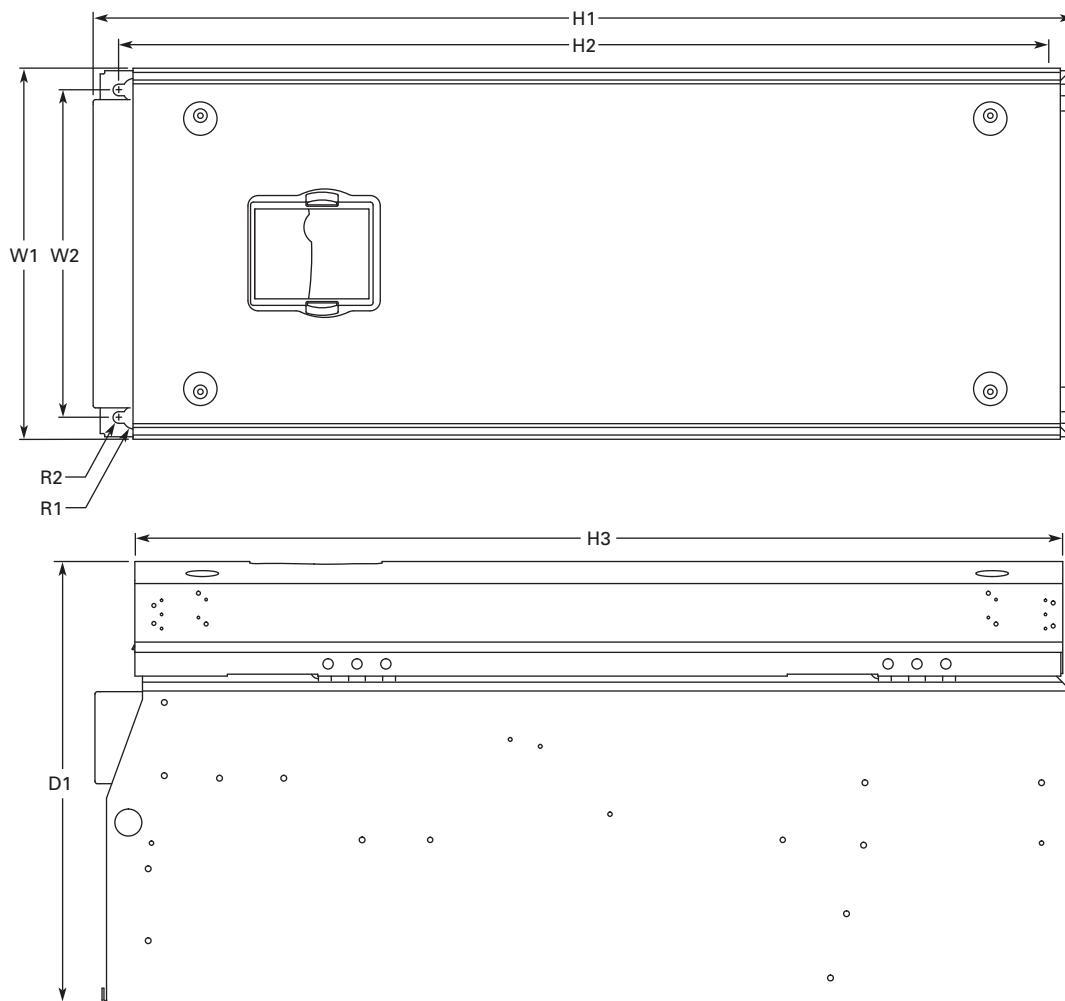

Voltage	hp (I <sub>H</sub> )	D1	H1	H2	H3	W1	W2	R1 Dia.	R2 Dia.	Weight Lbs (kg)
230V	40–60	13.5 (344)	300.1 (764)	28.8 (732)	28.4 (721)	11.5 (291)	10 (255)	0.7 (18)	0.4 (9)	127 (58)
480V	75–125									
575V	50–75									

Approximate Dimensions in Inches (mm)

**NEMA Type 1/IP21 and NEMA Type 12/IP54, with Flange Kit, FR7 and FR8**

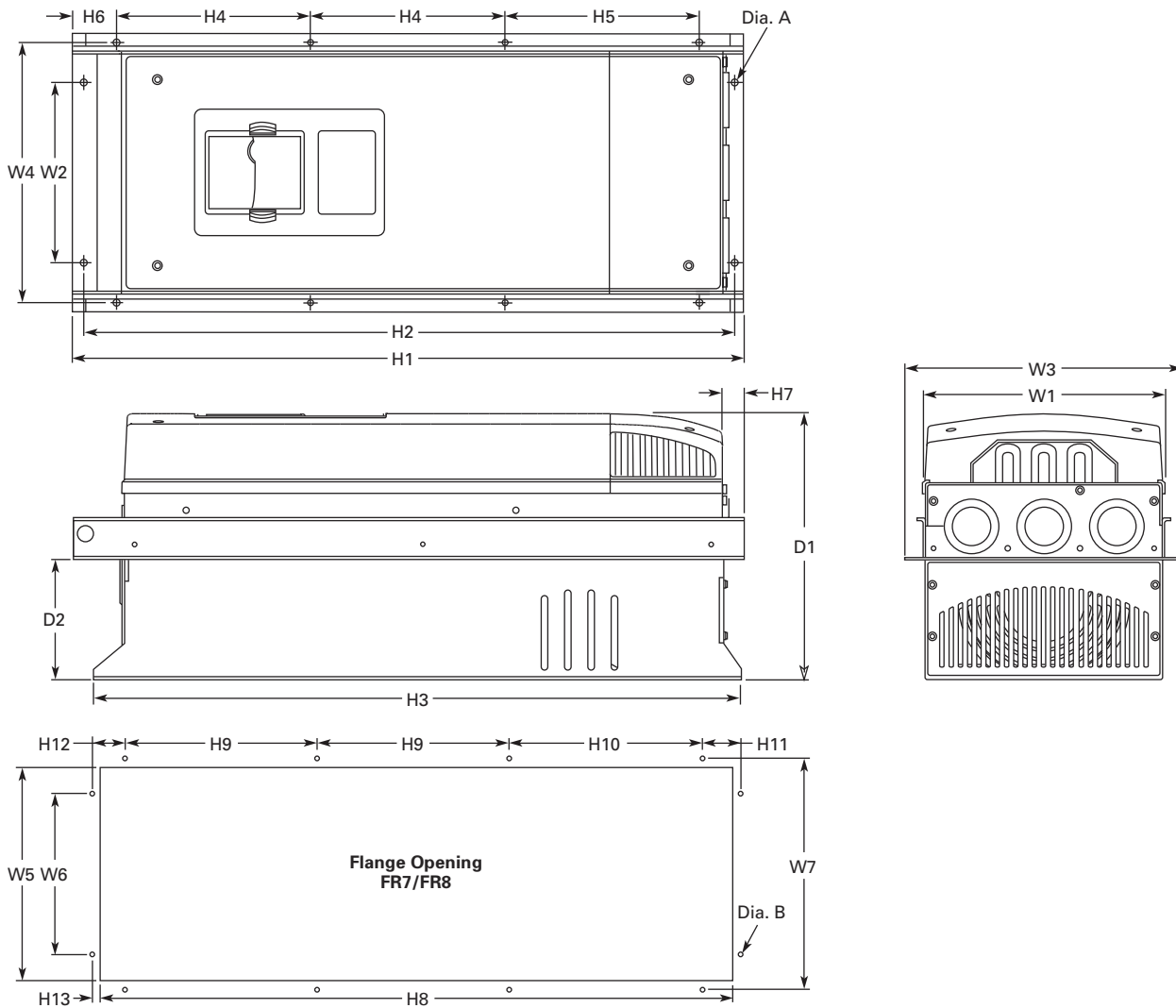

W1	W2	W3	W4	H1	H2	H3	H4	H5	H6	H7	D1	D2	Dia. A
<b>FR7</b>													
9.3 (237)	6.8 (175)	10.6 (270)	10.0 (253)	25.6 (652)	24.9 (632)	24.8 (630)	7.4 (189)	7.4 (189)	0.9 (23)	0.8 (20)	10.1 (257)	4.6 (117)	0.3 (6)
<b>FR8</b>													
11.2 (285)	—	14.0 (355)	13.0 (330)	32.8 (832)	—	29.3 (745)	10.2 (258)	10.4 (265)	1.7 (43)	2.2 (57)	13.5 (344)	4.3 (110)	0.4 (9)

**Flange Opening, FR7 and FR8**

W5	W6	W7	H8	H9	H10	H11	H12	H13	Dia. B
<b>FR7</b>									
9.2 (233)	6.9 (175)	10.0 (253)	24.4 (619)	7.4 (189)	7.4 (189)	1.4 (35)	1.3 (32)	1.0 (25)	0.3 (6)
<b>FR8</b>									
11.9 (301)	—	13.0 (330)	31.9 (810)	10.2 (258)	10.4 (265)	—	—	1.3 (33)	0.4 (9)

# 36.4 Adjustable Frequency Drives

## SPX9000 Drives

Approximate Dimensions in Inches (mm)

**NEMA Type 1/IP21 and NEMA Type 12/IP54, FR9**

36

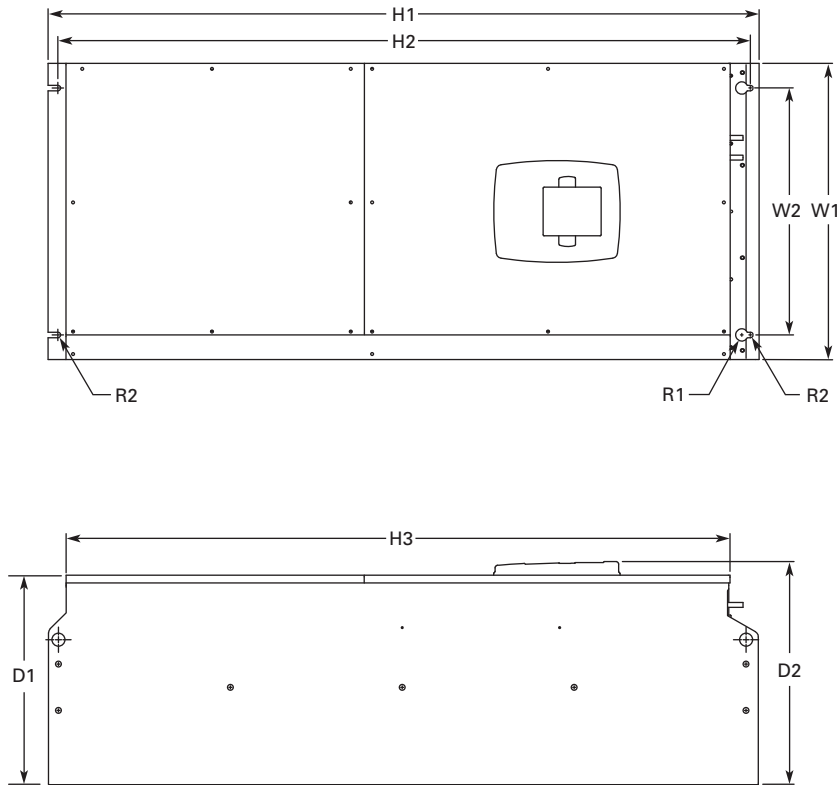

Voltage	hp (I <sub>H</sub> )	H1	H2	H3	D1	D2	W1	W2	R1 Dia.	R2 Dia.	Weight Lbs (kg)
230V	75–100	45.3 (1150)	44.1 (1120)	42.4 (1076)	13.4 (340)	14.3 (362)	18.9 (480)	15.7 (400)	0.8 (20)	0.4 (9)	322 (146)
480V	150–200										
575V	100–175										

Approximate Dimensions in Inches (mm)

**NEMA Type 1/IP21 and NEMA Type 12/IP54, FR9, continued**

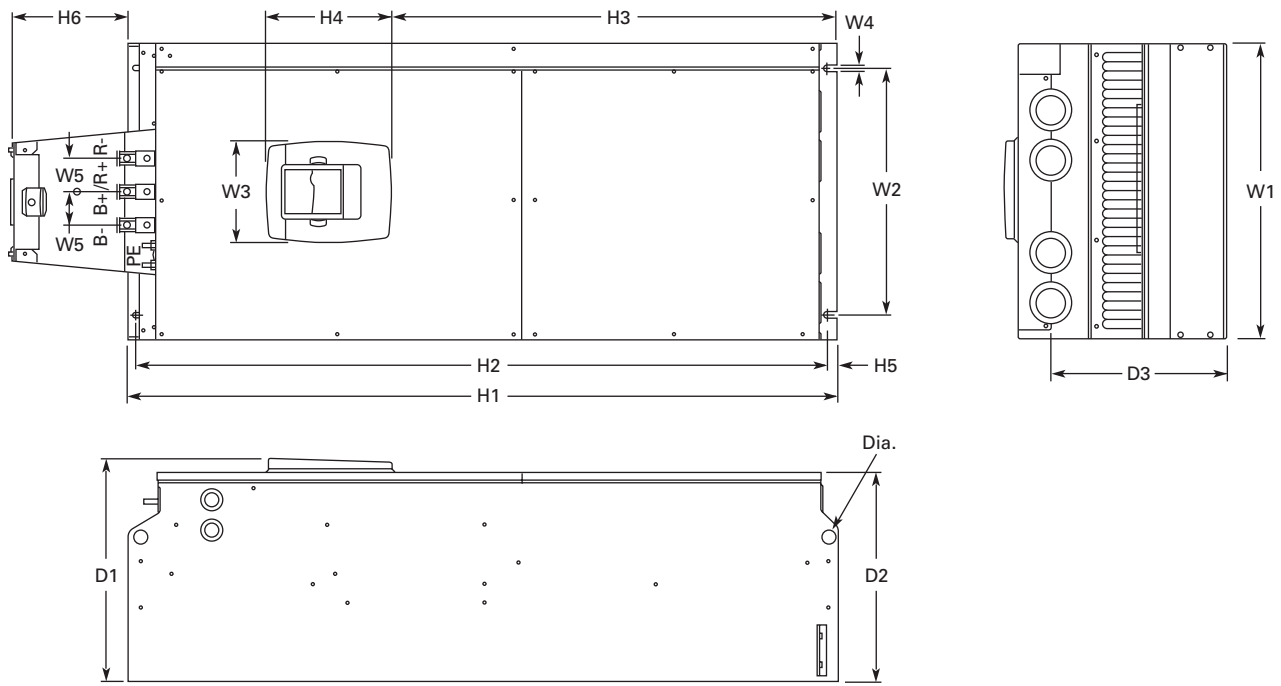

W1	W2	W3	W4	W5	H1	H2	H3	H4	H5	H6 ①	D1	D2	D3	Dia.
18.9 (480)	15.7 (400)	6.5 (165)	0.4 (9)	2.1 (54)	45.3 (1150)	44.1 (1120)	28.3 (721)	8.0 (205)	0.6 (16)	7.4 (188)	14.2 (361.5)	13.4 (340)	11.2 (285)	0.8 (21)

**Note**

① Brake resistor terminal box (H6) included when brake chopper ordered.

# 36.4 Adjustable Frequency Drives

SPX9000 Drives

Approximate Dimensions in Inches (mm)

## NEMA Type 1/IP21 and NEMA Type 12/IP54, FR9 with Flange Kit

36

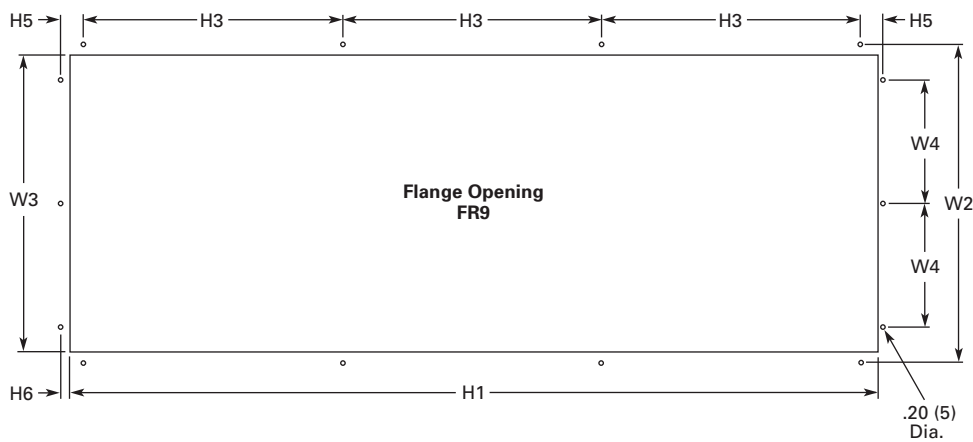
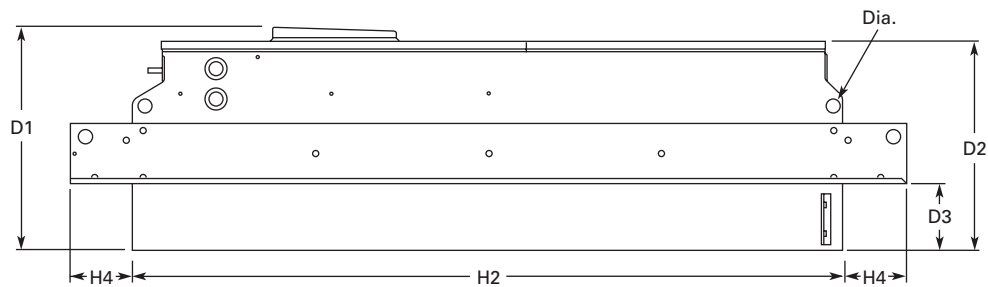
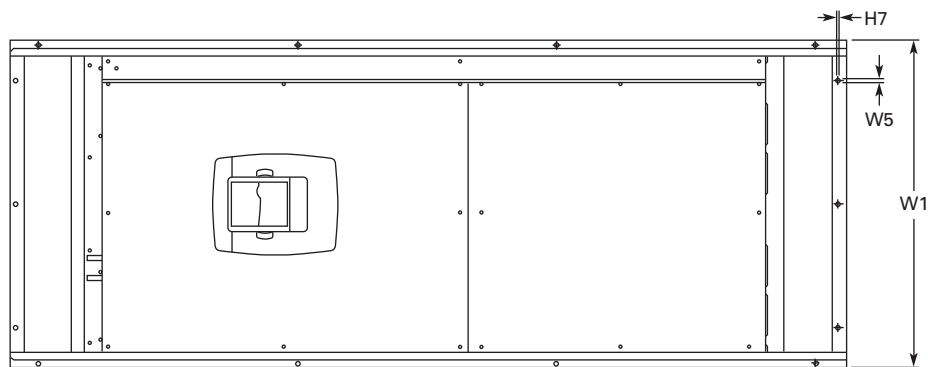

W1	W2	W3	W4	W5	H1	H2	H3	H4	H5	H6	H7	D1	D2	D3	Dia.
20.9 (530)	20.0 (510)	19.1 (485)	7.9 (200)	0.2 (5.5)	51.7 (1312)	45.3 (1150)	16.5 (420)	3.9 (100)	1.4 (35)	0.4 (9)	0.1 (2)	24.9 (362)	13.4 (340)	4.3 (109)	0.8 (21)



Approximate Dimensions in Inches (mm)

**NEMA Type 1/IP21 and NEMA Type 12/IP54, FR10 Freestanding**

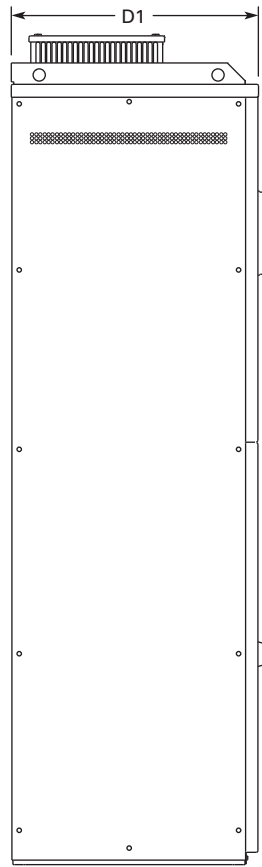
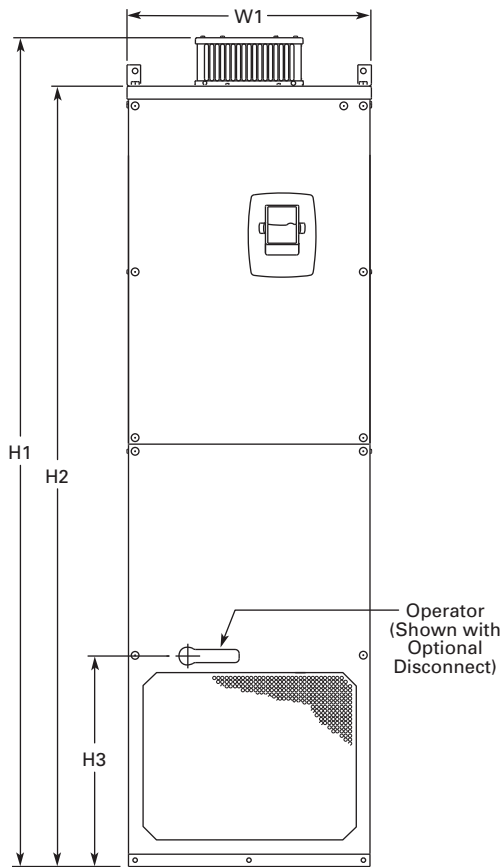
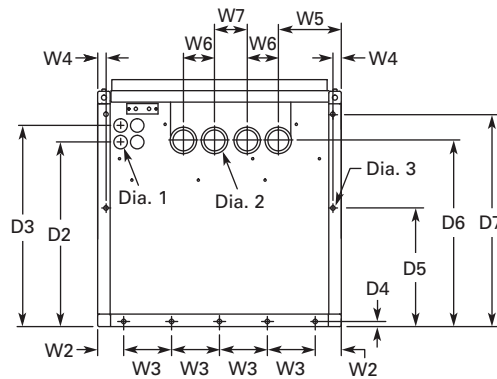
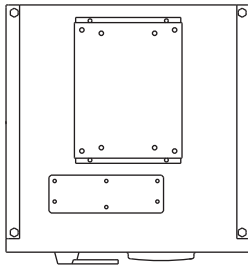

Volts	hp (I <sub>H</sub> )	W1	W2	W3	W4	W5	W6	W7	H1	H2	H3	D1	D2	D3	D4	D5	D6	D7	Dia. 1	Dia. 2	Dia. 3	Weight Lbs (kg)
480V	250–350	23.43	2.46	4.53	0.79	5.95	2.95	30.11	79.45	74.80	20.18	23.70	17.44	19.02	0.47	11.22	17.60	20.08	0.83	1.89	0.43	875 (389)
690V	200–300	(595)	(62.5)	(115)	(20)	(151)	(75)	(79)	(2018)	(1900)	(512.5)	(602)	(443)	(483)	(12)	(285)	(447)	(510)	(21)	(48)	(11)	

# 36.4 Adjustable Frequency Drives

## SPX9000 Drives

Approximate Dimensions in Inches (mm)

### FR10 Open Chassis ①

36

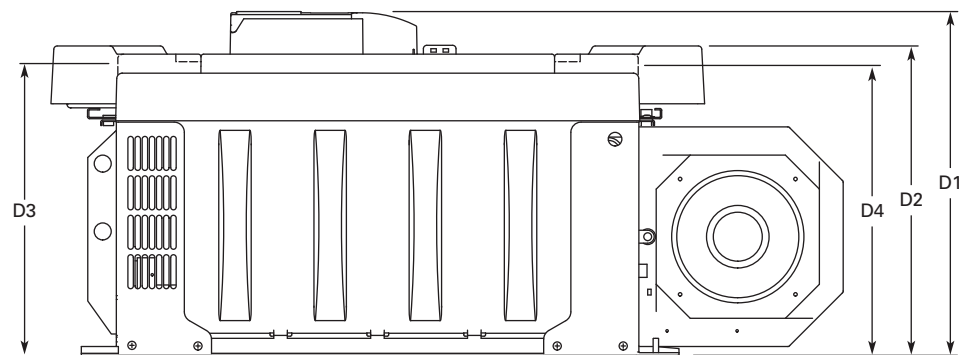
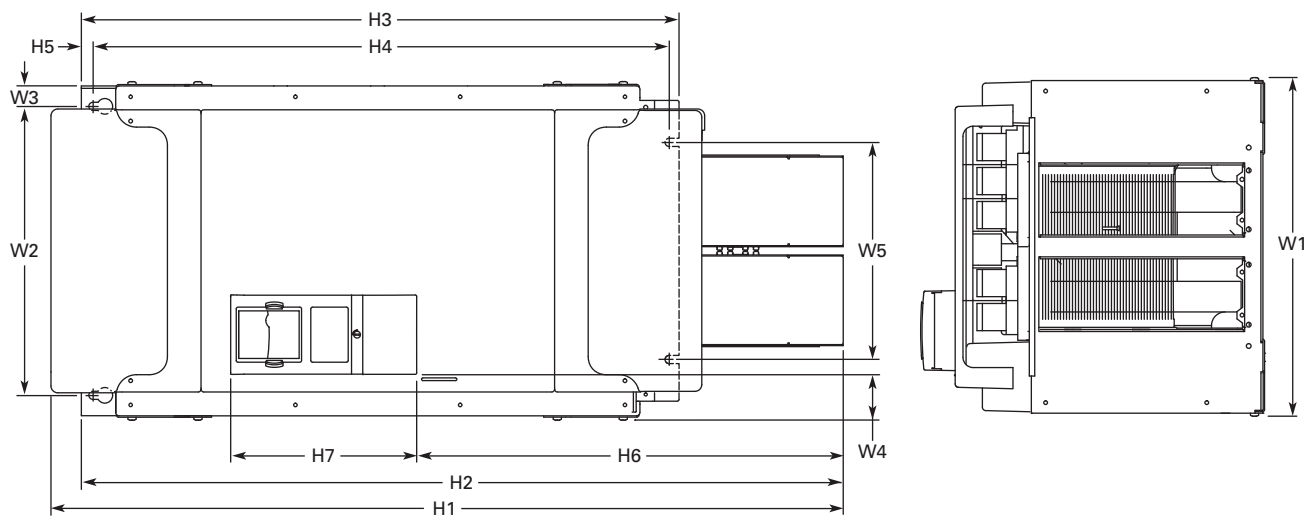

Voltage	hp (I <sub>H</sub> )	W1	W2	W3	W4	W5	H1	H2	H3	H4	H5	H6	H7	D1	D2	D3	D4	Weight Lbs (kg)
480V	250-350	19.7 (500)	16.7 (425)	1.2 (30)	2.6 (67)	12.8 (325)	45.9 (1165)	44.1 (1121)	34.6 (879)	33.5 (850)	0.7 (17)	24.7 (627)	10.8 (275)	19.9 (506)	17.9 (455)	16.7 (423)	16.6 (421)	518 (235)
575V	200-300																	

**Note**

① SPX9000X FR12 is built of two FR10 modules. Please refer to SPX9000 installation manual for mounting instructions.

Approximate Dimensions in Inches (mm)

### NEMA Type 1/IP21, FR11 Freestanding Drive

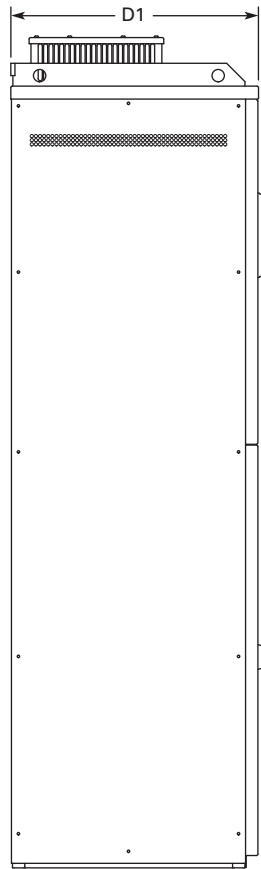
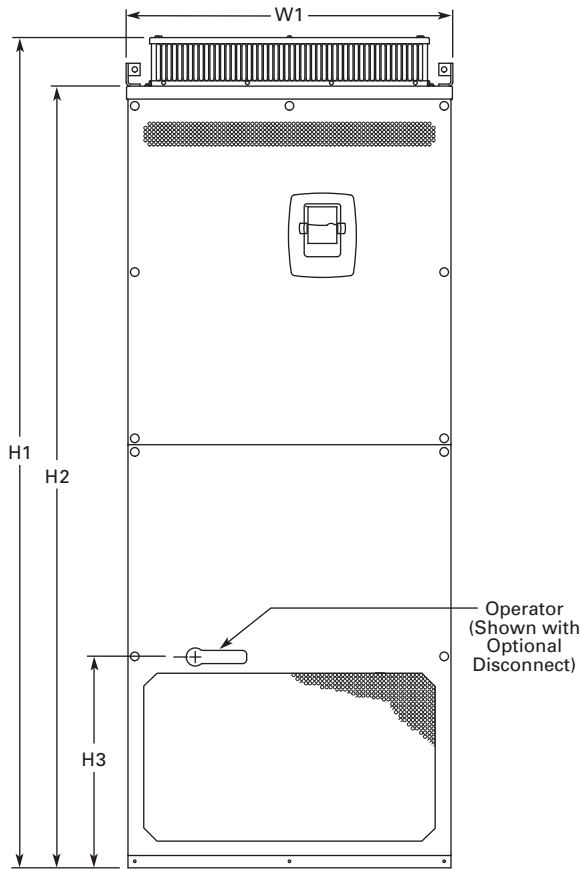
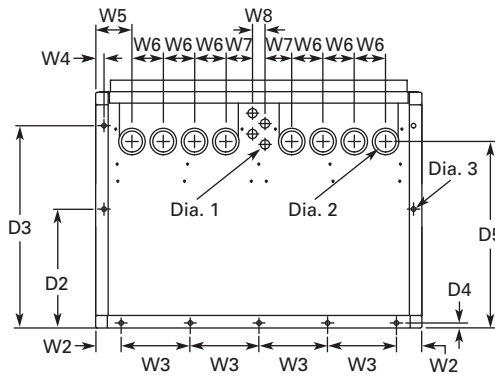
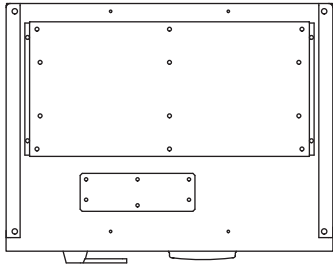

Voltage	hp (I <sub>H</sub> )	W1	W2	W3	W4	W5	W6	W7	W8	H1	H2	H3	D1	D2	D3	D4	D5	Dia. 1	Dia. 2	Dia. 3	Weight Lbs (kg)
480V	400-550	31.26 (794)	2.40 (61)	6.50 (165)	0.79 (20)	3.43 (87)	2.95 (75)	2.52 (64)	1.18 (30)	79.45 (2018)	74.80 (1900)	20.18 (512.5)	23.70 (602)	11.22 (285)	19.09 (485)	0.47 (12)	17.60 (447)	0.83 (21)	1.89 (48)	0.35 x 0.43 (9 x 11)	526 (239)
690V	400-500																				

# 36.4 Adjustable Frequency Drives

## SPX9000 Drives

Approximate Dimensions in Inches (mm)

### FR11 Open Chassis

36

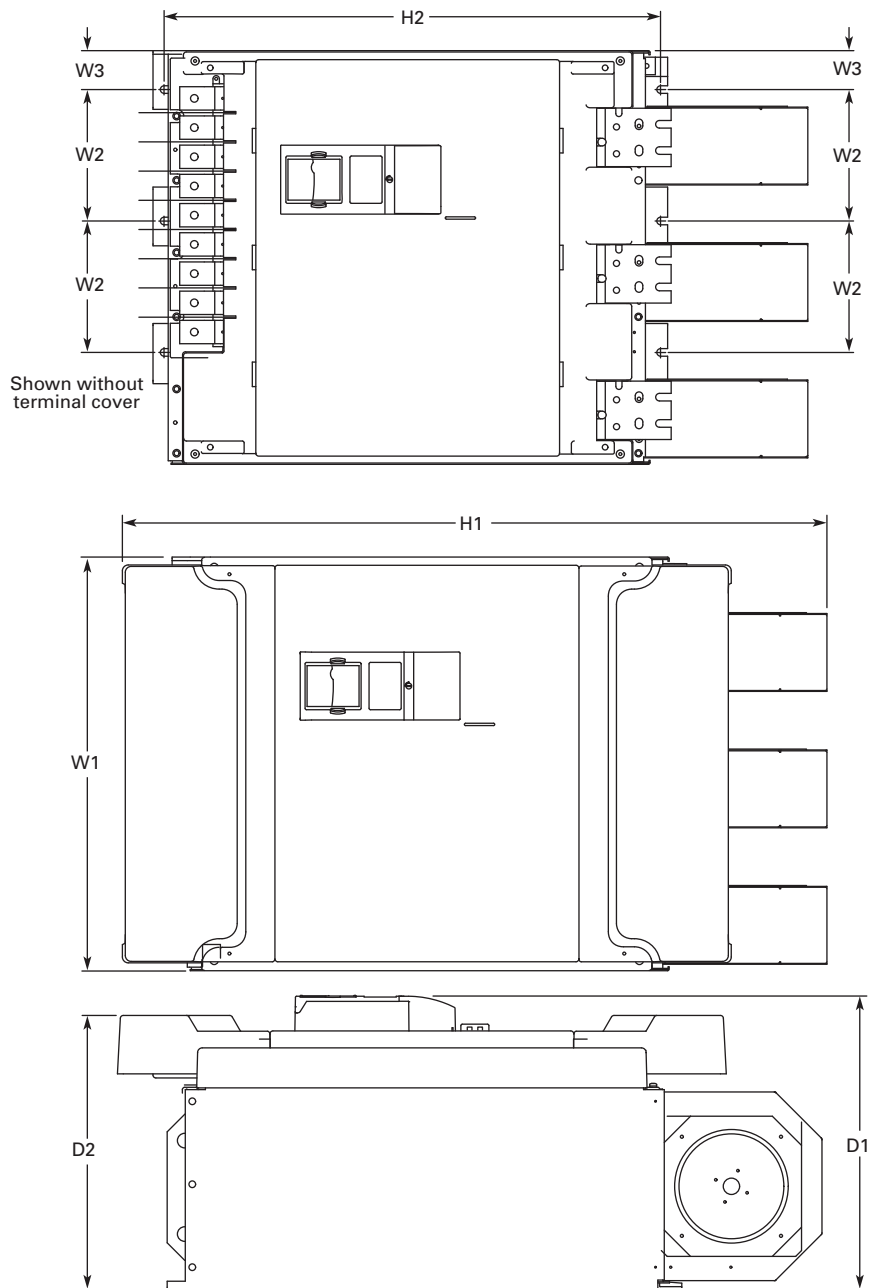

Voltage	hp (I <sub>H</sub> )	W1	W2	W3	H1	H2	D1	D2	Weight Lbs (kg)
480V	400-550	27.9 (709)	8.6 (225)	2.6 (67)	45.5 (1155)	33.5 (850)	19.8 (503)	18.4 (468)	833 (378)
575V	400-500								

Approximate Dimensions in Inches (mm)

### FR13, Open Chassis Inverter

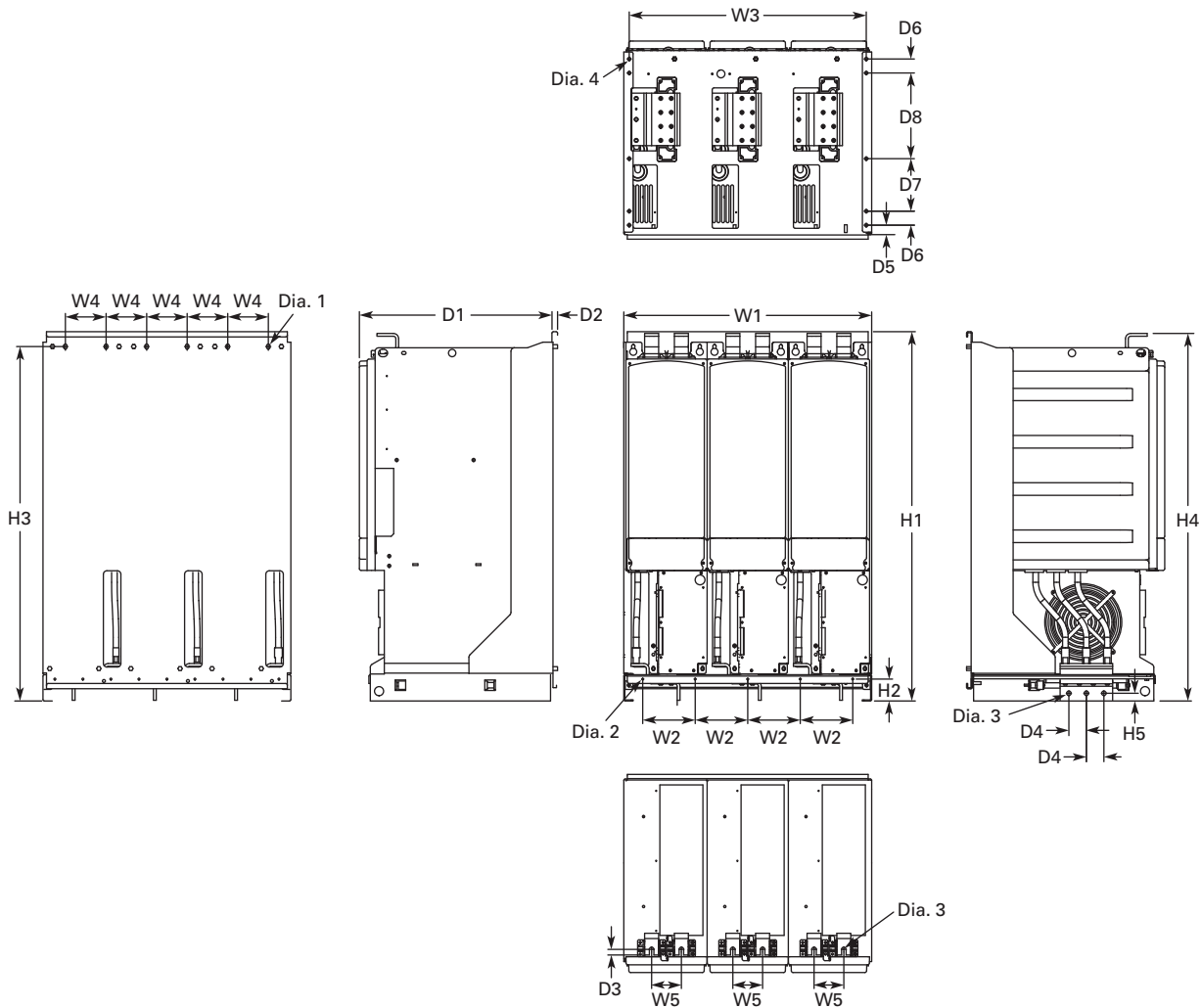

W1	W2	W3	W4	W5	H1	H2	H3	H4	H5	D1	D2	D3	D4	D5	D6	D7	D8	Dia. 1	Dia. 2	Dia. 3	Dia. 4	Weight Lbs (kg)
27.87 (708)	5.91 (150)	26.65 (677)	4.57 (116)	3.35 (85)	41.54 (1055)	2.46 (62.5)	39.86 (1012.5)	41.34 (1050)	0.79 (20)	21.77 (553)	0.51 (13)	0.63 (16)	1.97 (50)	1.06 (27)	1.57 (40)	5.91 (150)	9.64 (244.8)	0.35x0.59 (9x15)	0.18 (4.6)	0.51 (13)	0.37 (9.5)	683 (310)

**Notes**

9000X FR14 is built of two FR13 modules. Please refer to SPX9000 installation manual for mounting instructions.  
 FR13 is built from an inverter module and a converter module. Please refer to SPX9000 installation manual for mounting instructions.

# 36.4 Adjustable Frequency Drives

## SPX9000 Drives

Approximate Dimensions in Inches (mm)

### FR13, Open Chassis Converter

36

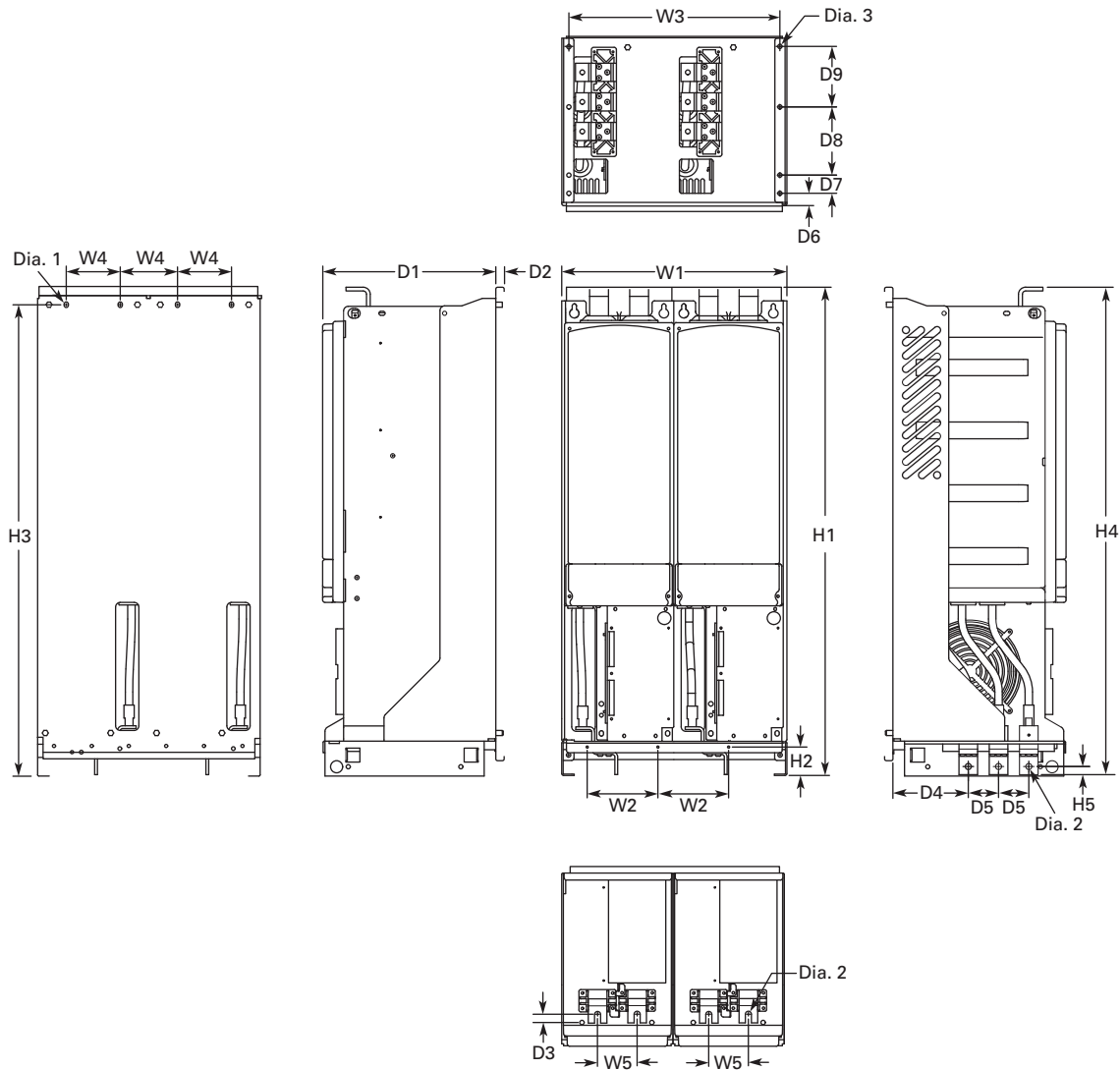

W1	W2	W3	W4	W5	H1	H2	H3	H4	H5	D1	D2	D3	D4	D5	D6	D7	D8	D9	Dia. 1	Dia. 2	Dia. 3	Weight Lbs (kg)
18.74 (476)	5.91 (150)	17.52 (445)	4.57 (116)	3.35 (85)	41.54 (1055)	2.46 (62.5)	39.86 (1012.5)	41.34 (1050)	0.69 (17.5)	14.69 (373)	0.51 (13)	0.73 (18.5)	6.42 (163)	2.56 (65)	1.06 (27)	1.57 (40)	5.91 (150)	5.24 (133)	0.35x0.59 (9x15)	0.51 (13)	0.37 (9.5)	295 (134)

### Number of Input Units

480V Catalog Number	hp	Input Modules
SPX800A0-4A2N1	800	2

690V Catalog Number	hp	Input Modules
SPX800A0-5A2N1	800	2
SPX900A0-5A2N1	900	2
SPXH10A0-5A2N1	1000	2

Approximate Dimensions in Inches (mm)

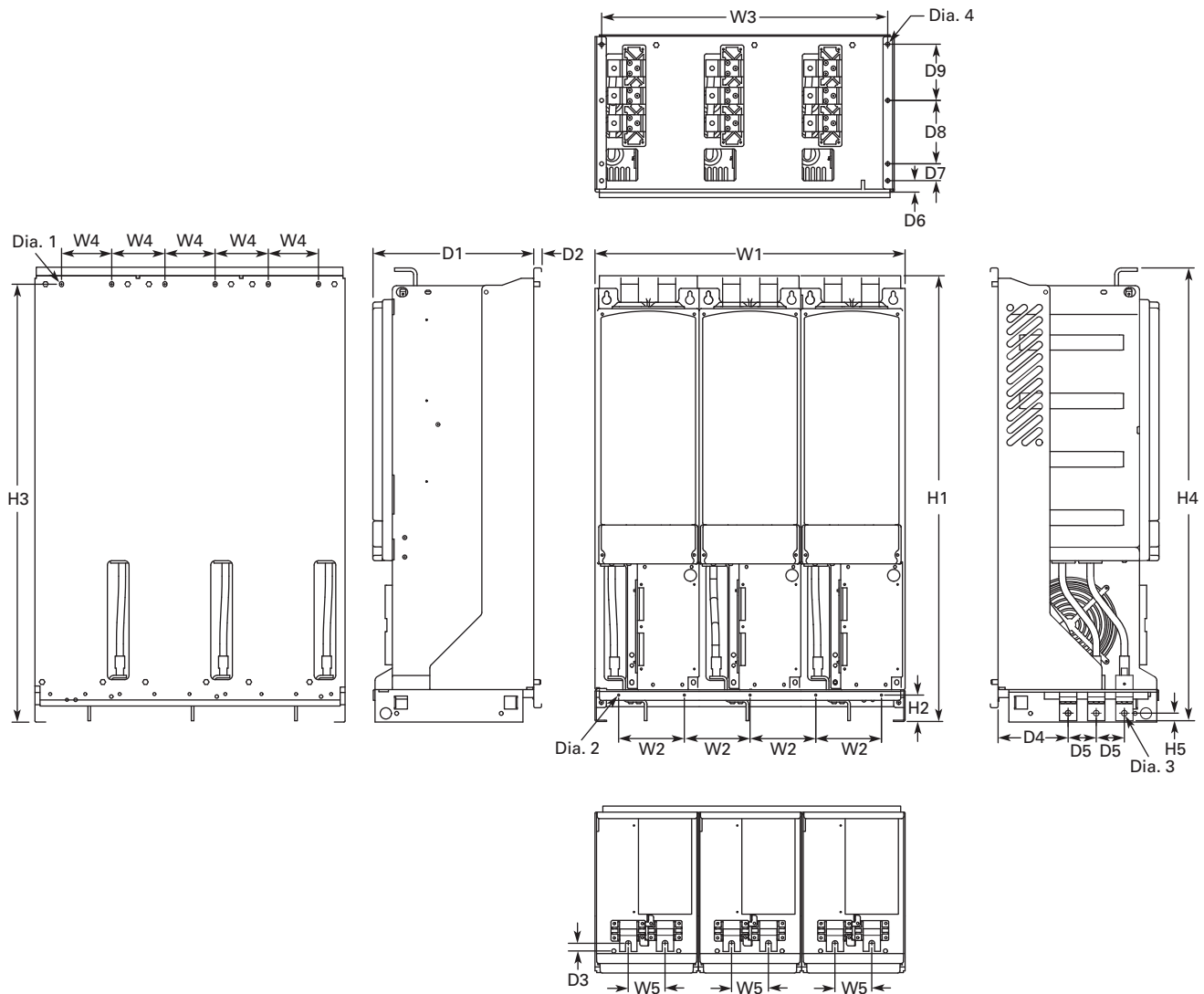
**FR13, Open Chassis Converter—900/1000 hp 480V**

W1	W2	W3	W4	W5	H1	H2	H3	H4	H5	D1	D2	D3	D4	D5	D6	D7	D8	D9	Dia. 1	Dia. 2	Dia. 3	Dia. 4	Weight Lbs (kg)
27.87 (708)	5.91 (150)	26.65 (677)	4.57 (116)	3.35 (85)	41.54 (1055)	2.46 (62.5)	39.86 (1012.5)	41.34 (1050)	0.69 (17.5)	14.69 (373)	0.51 (13)	0.73 (18.5)	6.42 (163)	2.56 (65)	1.06 (27)	1.57 (40)	5.91 (150)	5.24 (133)	0.35x0.59 (9x15)	0.18 (4.6)	0.51 (13)	0.37 (9.5)	443 (201)

**Number of Input Units**

480V Catalog Number	hp	Input Modules
SPX900A0-4A2N1	900	3
SPXH10A0-4A2N1	1000	3

# 36.4

## Adjustable Frequency Drives

### SPX9000 Drives

Approximate Dimensions in Inches (mm)

36

#### AC Choke Dimensions

##### Choke Types

Catalog Number	Frame Size	Choke Type ①	Catalog Number	Frame Size	Choke Type ①
<b>Voltage Range 380–500V</b>			<b>Voltage Range 525–690V</b>		
SPX 250 4	FR10	CHK0400	SPX 200 5	FR10	CHK0261
SPX 300 4		CHK0520	SPX 250 5		CHK0400
SPX 350 4		CHK0520	SPX 300 5		CHK0400
SPX 400 4	FR11	2 x CHK0400	SPX 400 5	FR11	CHK0520
SPX 500 4		2 x CHK0400	SPX 450 5		CHK0520
SPX 550 4		2 x CHK0400	SPX 500 5		2 x CHK0400
SPX 600 4	FR12	2 x CHK0520	SPX 550 5	FR12	2 x CHK0400
SPX 650 4		2 x CHK0520	SPX 600 5		2 x CHK0400
SPX 700 4		2 x CHK0520	SPX 700 5		2 x CHK0400
SPX 800 4	FR13	2 x CHK0400	SPX 800 5	FR13	2 x CHK0400
SPX 900 4		3 x CHK0520	SPX 900 5		2 x CHK0400
SPX H10 4		3 x CHK0520	SPX H10 5		2 x CHK0400
SPX H12 4	FR14	4 x CHK0520	SPX H13 5	FR14	4 x CHK0400
SPX H16 4		6 x CHK0400	SPX H15 5		6 x CHK0400

#### CHK0520

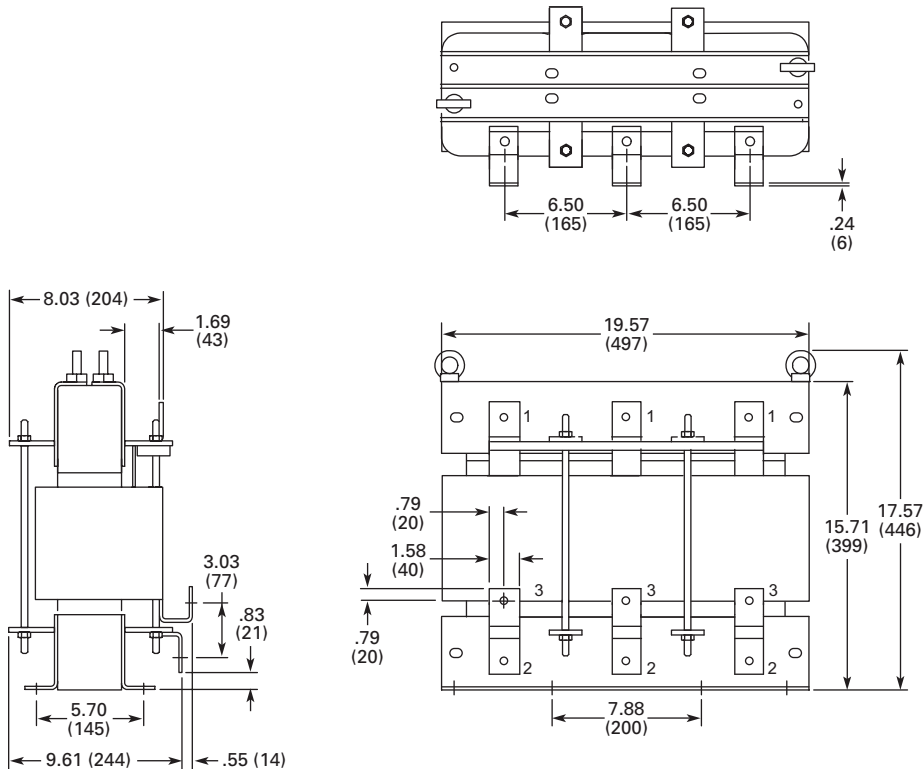

#### Note

① Chokes are provided with all FR10–FR14 drives.



Approximate Dimensions in Inches (mm)

## CHK0400

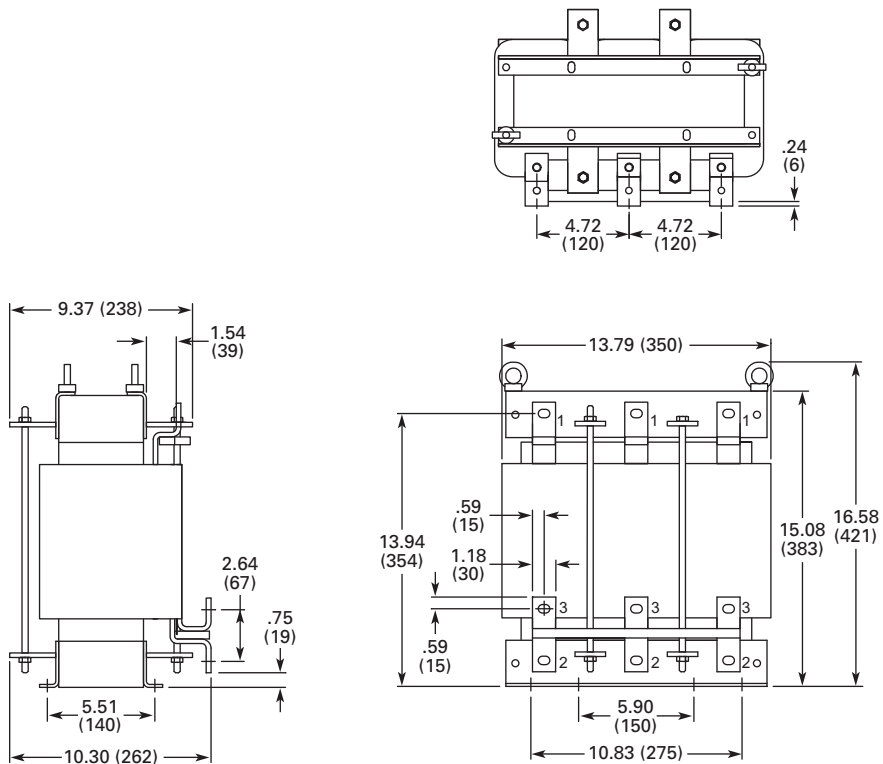

## CHK0261

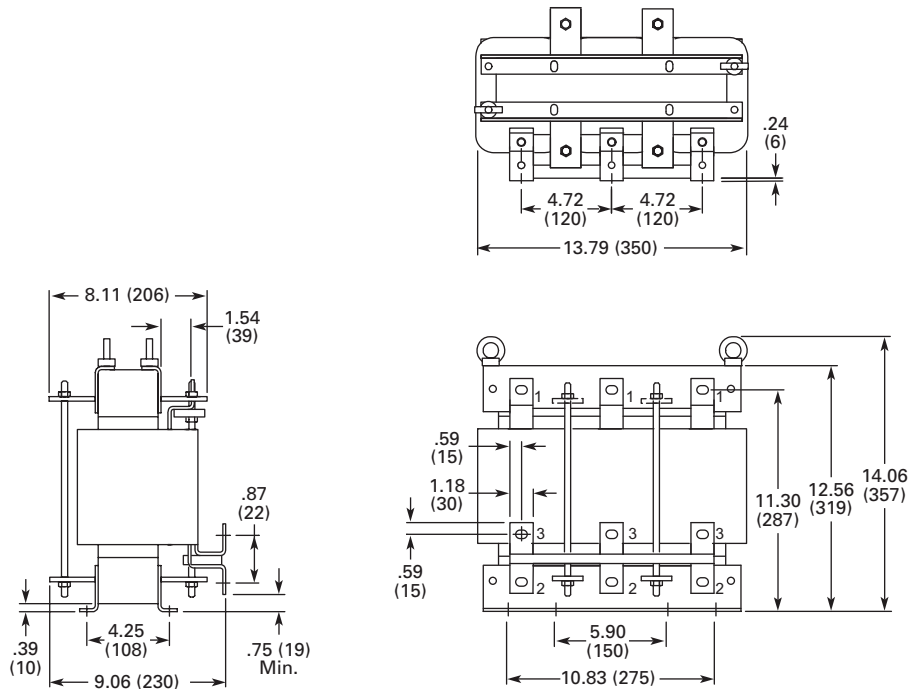

H-Max Series Drives



### Contents

**Description**

**Page**

H-Max Series Drives	
H-Max Drives	<b>V6-T36-139</b>
H-Max IntelliPass and IntelliDisconnect Drives	<b>V6-T36-149</b>

### Product Overview

#### Drives

Eaton's H-Max™ Series VFD is the next generation of drives specifically engineered for HVAC, pump and fluid control applications. Installation, startup and maintenance are world-class with a combination of ultra-efficient power section and programmable main control board.

H-Max Series has an expanded startup wizard for HVAC system configuration, which provides the flexibility to meet consultants, OEM and end-user requirements.

#### Features

- Integrated DC link choke standard on drives from FS4-FS9
- DC bus regulation anti-trip
- Input surge protection against voltage spikes varistor input
- HAND/OFF/AUTO and DRIVE/BYPASS selector on keypad simplifies control
- Additional I/O and communication cards provide plug-and-play functionality
- **Keypad**—copy/paste function allows transfer of parameter settings from one drive to the next
- **Battery Backup**—real-time clock with PLC functionality
- Two independent PID functions
- Multimonitor up to nine values
- 110% overload for one minute once every ten minutes
- EMC Category 2
- Standard EMI/RFI filter
- Conformal coated boards
- Troubleshooting diagnostics
- Onboard RS-485 (Modbus, N2, FLN, BACnet)
- Onboard Ethernet-based communications (BACnet/IP, Modbus/TCP)
- Separate conduit plate allows access to control and power connections
- DB chopper standard frames FS4-FS6 for
  - 1.5–40 hp, 1.1–30 kW, 3.4–61 amp, 480 Vac
  - 0.75–20 hp, 0.55–15 kW, 3.7–62 amp, 200–240 Vac
- OHSPD Special Seismic Certification Pre-Approved
- UL 508C

#### IntelliPass and IntelliDisconnect Drives

Eaton's ultra-reliable IntelliPass/IntelliDisconnect drives are designed with the latest HVAC software and hardware features. The IntelliPass integrates electronic (**XT**) bypass with optional manual override switch, which allows the unit to run in bypass without the H-Max Series drive.

The IntelliDisconnect uses Eaton's world-class (**XT**) MMP (manual motor protector) with optional output contactor.

#### Features

- #### IntelliPass/IntelliDisconnect
- Circuit breaker provides flexible drive isolation configurations to meet customers' needs
  - Robust steel enclosure for simple installation

#### IntelliPass

- Mechanical, electronic and damper interlocks
- Fire mode
- Monitored and controlled by onboard communication
- Two contactor, mechanically interlocked and fully rated bypass
- Single keypad with HAND/OFF/AUTO and DRIVE/BYPASS simplifies startups and control
- Two power sources for control ensure redundancy and provide additional ride-through capability
- NEMA Type 1
- Programmable auto restart and auto bypass while allowing critical damper interlock functionality

## H-Max Drives



## H-Max Drives

## Product Description

Eaton's H-Max Series VFD has software and hardware designed specifically for the HVAC, pump industry. The ultra-efficient DC capacitor and power structure allows the drive to consume less energy, lowering greenhouse gases.

The I/O configuration is designed with wiring ergonomics in mind by including removable terminal blocks. The main, easily removable, control board used for all drive frames with six digital IN, two analog IN, one analog OUT, three relay OUT accepts two additional I/O or communication board. In addition, the control board has built-in RS-485 and Ethernet communication.

These drives continue the tradition of robust performance, and raise the bar on features and functionality, ensuring the best solution at the right price.

## Features and Benefits

- Integrated DC link choke standard on drives from FS4 through FS9
- DC bus regulation anti-trip
- Input surge protection against voltage spikes varistor input
- EMI/RFI filters standard on all drives from FS4 through FS9 to meet EMC Category 2
- HAND/OFF/AUTO and DRIVE/BYPASS selector on keypad simplifies control
- Additional I/O and communication cards provide plug-and-play functionality
- Copy/paste function allows transfer of parameter settings from one drive to the next
- Keypad can display up to nine monitored parameters simultaneously
- Remote mount keypad kit available
- NEMA Type 1 and NEMA Type 12 available
- Real-time clock with PLC functionality
- Two independent PID functions
- On-screen troubleshooting diagnostics with embedded manual assistance
- Onboard RS-485 (Modbus, N2, FLN, BACnet)
- Onboard Ethernet-based communications (BACnet/IP, Modbus/TCP)
- Standard NEMA Type 12 keypad on all drives
- Quickstart wizard built into programming of drive ensures a smooth startup
- I/O connections with simple quick connection terminals
- Control logic can be powered from an external 24V power supply to simulate internal drive functions and fieldbus, if necessary, used for testing and software downloads
- Standard I/O, 6DI, 2AI, 1AO 2 Form C RO (NO/NC), 1 Form A RO (NO)
- Hard wired external/damper interlock

## Standards and Certifications

## Product

- IEC 61800-5-1
- CE
- cUL

## Safety

- UL 508C
- EN 61800-5-1
- CE
- cUL



- OHSPD Special Seismic Certification Pre-Approved

## Contents

## Description

## Page

H-Max Drives	
Catalog Number Selection	V6-T36-140
Product Selection	V6-T36-141
Replacement Parts	V6-T36-145
Technical Data and Specifications	V6-T36-146
Wiring Diagram	V6-T36-147
Dimensions	V6-T36-148
H-Max IntelliPass and IntelliDisconnect Drives	V6-T36-149

# 36.5

## Adjustable Frequency Drives

### H-Max Series Drives

#### Catalog Number Selection

#### H-Max Series Drives

36

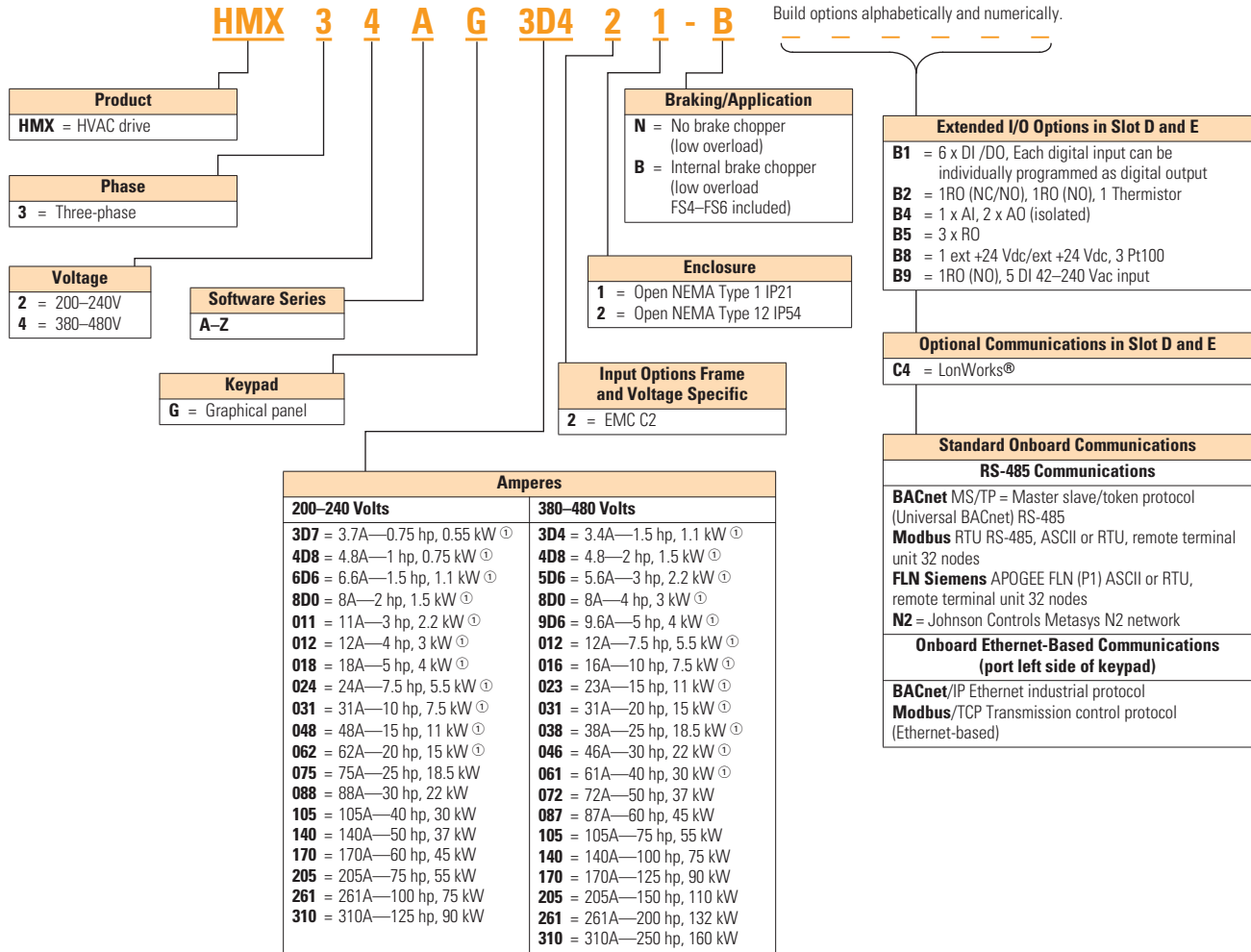

#### Notes

All boards are varnished (conformed coated). Corrosion resistant.

Battery included in all drives for real-time clock.

Keypad kit includes HOA bypass.

Keypad kit includes HOA, back reset for Europe application.

EMI/RFI filters included.

DC link choke included.

① DB chopper standard frames FS4–FS6: 1.5–40 hp, 3.4–61 amp, 480 Vac; 0.75–20 hp, 3.7–62 amp, 200–240 Vac.

## Product Selection

## H-Max Series Drives—230 Vac

## NEMA Type 1



## NEMA Type 1/IP21

FS Frame Size	Drive Output Current		Assigned Motor Ratings			Catalog Number
	Low Overload Full Load Amps at 40°C	Horsepower	Drive kW 230 Vac/50 Hz	230 Vac NEC Amps <sup>①</sup>	Low Overload Full Load Amps at 50°C	
4	3.7	0.75	0.55	3.2	2.6	HMX32AG3D721-B <sup>②</sup>
	4.8	1	0.75	4.2	3.7	HMX32AG4D821-B <sup>②</sup>
	6.6	1.5	1.1	6.6	4.8	HMX32AG6D621-B <sup>②</sup>
	8	2	1.5	6.8	6.6	HMX32AG8D021-B <sup>②</sup>
	11	3	2.2	9.6	8	HMX32AG01121-B <sup>②</sup>
	12.5	4	3	N/A	11	HMX32AG01221-B <sup>②</sup>
5	18	5	4	15.2	12.5	HMX32AG01821-B <sup>②</sup>
	24	7.5	5.5	22	18	HMX32AG02421-B <sup>②</sup>
	31	10	7.5	28	24	HMX32AG03121-B <sup>②</sup>
6	48	15	11	42	31	HMX32AG04821-B <sup>②</sup>
	62	20	15	54	48	HMX32AG06221-B <sup>②</sup>
7	75	25	18.5	68	62	HMX32AG07521-N
	88	30	22	80	75	HMX32AG08821-N
	105	40	30	104	88	HMX32AG10521-N
8	140	50	37	130	105	HMX32AG14021-N
	170	60	45	154	140	HMX32AG17021-N
	205	75	55	192	170	HMX32AG20521-N
9	261	100	75	248	205	HMX32AG26121-N
	310	125	90	N/A	261	HMX32AG31021-N

## NEMA Type 12



## NEMA Type 12/IP54

FS Frame Size	Drive Output Current		Assigned Motor Ratings			Catalog Number
	Low Overload Full Load Amps at 40°C	Horsepower	Drive kW 230 Vac/50 Hz	230 Vac NEC Amps <sup>①</sup>	Low Overload Full Load Amps at 50°C	
4	3.7	0.75	0.55	3.2	2.6	HMX32AG3D722-B <sup>②</sup>
	4.8	1	0.75	4.2	3.7	HMX32AG4D822-B <sup>②</sup>
	6.6	1.5	1.1	6.6	4.8	HMX32AG6D622-B <sup>②</sup>
	8	2	1.5	6.8	6.6	HMX32AG8D022-B <sup>②</sup>
	11	3	2.2	9.6	8	HMX32AG01122-B <sup>②</sup>
	12.5	4	3	N/A	11	HMX32AG01222-B <sup>②</sup>
5	18	5	4	15.2	12	HMX32AG01822-B <sup>②</sup>
	24	7.5	5.5	22	18	HMX32AG02422-B <sup>②</sup>
	31	10	7.5	28	24	HMX32AG03122-B <sup>②</sup>
6	48	15	11	42	31	HMX32AG04822-B <sup>②</sup>
	62	20	15	54	48	HMX32AG06222-B <sup>②</sup>
7	75	25	18.5	68	62	HMX32AG07522-N
	88	30	22	80	75	HMX32AG08822-N
	105	40	30	104	88	HMX32AG10522-N
8	140	50	37	130	105	HMX32AG14022-N
	170	60	45	154	140	HMX32AG17022-N
	205	75	55	192	170	HMX32AG20522-N
9	261	100	75	248	205	HMX32AG26122-N
	310	125	90	N/A	261	HMX32AG31022-N

## Notes

<sup>①</sup> For sizing reference.

<sup>②</sup> DB chopper standard frames FS4–FS6. 0.75–20 hp, 3.7–62 amp, 200–240 Vac.

#### H-Max Series Drives—480 Vac

36

##### NEMA Type 1



##### NEMA Type 1/IP21

FS Frame Size	Drive Output Current		Assigned Motor Ratings			Catalog Number
	Low Overload Full Load Amps at 40°C	Horsepower	Drive kW 400 Vac/50 Hz	480 Vac NEC Amps ①	Low Overload Full Load Amps at 50°C	
4	3.4	1.5	1.1	2.1	2.6	HMX34AG3D421-B ②
	4.8	2	1.5	3.4	3.4	HMX34AG4D821-B ②
	5.6	3	2.2	5.6	4.8	HMX34AG5D621-B ②
	8.0	4	3.0	N/A	5.6	HMX34AG8D021-B ②
	9.6	5	4	7.6	8	HMX34AG9D621-B ②
	12	7.5	5.5	11	9.6	HMX34AG01221-B ②
5	16	10	7.5	14	12	HMX34AG01621-B ②
	23	15	11	21	16	HMX34AG02321-B ②
	31	20	15	27	23	HMX34AG03121-B ②
6	38	25	18.5	34	31	HMX34AG03821-B ②
	46	30	22	40	38	HMX34AG04621-B ②
	61	40	30	52	46	HMX34AG06121-B ②
7	72	50	37	65	61	HMX34AG07221-N
	87	60	45	77	72	HMX34AG08721-N
	105	75	55	96	87	HMX34AG10521-N
8	140	100	75	124	105	HMX34AG14021-N
	170	125	90	156	140	HMX34AG17021-N
	205	150	110	180	170	HMX34AG20521-N
9	261	200	132	240	205	HMX34AG26121-N
	310	250	160	302	261	HMX34AG31021-N

##### NEMA Type 12



##### NEMA Type 12/IP54

FS Frame Size	Drive Output Current		Assigned Motor Ratings			Catalog Number
	Low Overload Full Load Amps at 40°C	Horsepower	Drive kW 400 Vac/50 Hz	480 Vac NEC Amps ①	Low Overload Full Load Amps at 50°C	
4	3.4	1.5	1.1	2.1	2.6	HMX34AG3D422-B ②
	4.8	2	1.5	3.4	3.4	HMX34AG4D822-B ②
	5.6	3	2.2	5.6	4.8	HMX34AG5D622-B ②
	8.0	4	3.0	N/A	5.6	HMX34AG8D022-B ②
	9.6	5	4	7.6	8	HMX34AG9D622-B ②
	12	7.5	5.5	11	9.6	HMX34AG01222-B ②
5	16	10	7.5	14	12	HMX34AG01622-B ②
	23	15	11	21	16	HMX34AG02322-B ②
	31	20	15	27	23	HMX34AG03122-B ②
6	38	25	18.5	34	31	HMX34AG03822-B ②
	46	30	22	40	38	HMX34AG04622-B ②
	61	40	30	52	46	HMX34AG06122-B
7	72	50	37	65	61	HMX34AG07222-N
	87	60	45	77	72	HMX34AG08722-N
	105	75	55	96	87	HMX34AG10522-N
8	140	100	75	124	105	HMX34AG14022-N
	170	125	90	156	140	HMX34AG17022-N
	205	150	110	180	170	HMX34AG20522-N
9	261	200	132	240	205	HMX34AG26122-N
	310	250	160	302	261	HMX34AG31022-N

##### Notes

- ① For sizing reference.
- ② DB chopper standard frames FS4–FS6. 1.5–40 hp, 3.4–61 amp, 480 Vac.

**Onboard Network Communications****Johnson Controls Metasys N2**

H-Max Series provides communication between the drive and a Johnson Controls Metasys™ N2 network. With this connection, the drive can be controlled, monitored and programmed from the Metasys system. N2 can be selected and programmed by the drive keypad.

**BACnet**

H-Max Series provides communication to BACnet networks. Data transfer is master-slave/token passing (MS/TP) RS-485.

**BACnet IP**

100 base T interface.

**Modbus TCP**

Ethernet based protocol.

**Modbus RTU**

H-Max Series provides communication to Modbus RTU RS-485 as a slave on a Modbus network. Other communication parameters include an address range from 1–247; a parity of None, Odd or Even; and the stop bit is 1.

**FLN**

H-Max Series provides communication to Siemens APOGEE™ FLN (P1) RTU RS-485 as a slave on an FLN network. Other communication parameters include an address range from 1–247, a parity of None, Odd or Even and option boards.

**H-Max Series Option Board Kits Available for Slots D and E**

The H-Max Series drives can accommodate a wide selection of expander and adapter option boards to customize the drive for your

application needs. The drive's control unit is designed to accept a total of two option boards.

The H-Max Series factory-installed standard board configuration includes an I/O board and a relay output board.

**Option Boards Mounted in Slots D and E**

Option Kit Description	Option Kit Catalog Number
6 x DI /DO, each digital input can be individually programmed as digital output	<b>XXM-IO-B1-A</b>
1RO Form C (NO/NC), 1RO Form A (NO), 1 thermistor	<b>XXM-IO-B2-A</b>
1 x AI, 2 x AO (isolated)	<b>XXM-IO-B4-A</b>
3 x RO Form A (NO)	<b>XXM-IO-B5-A</b>
1 ext +24 Vdc/ext +24 Vdc, 3 Pt100	<b>XXM-IO-B8-A</b>
1RO Form A (NO), 5DI 42–240 Vac input	<b>XXM-IO-B9-A</b>
LonWorks®	<b>XXM-COM-C4-A</b>

**NEMA Type 1 to NEMA Type 12/IP54 Conversion Kit**

The NEMA Type 12/IP54 option kit is used to convert a NEMA Type 1 to a NEMA Type 12 drive.

Kit consists of a drive cover, fan kit and plugs.

**NEMA Type 12/IP54 Cover**

Option Kit Description	Option Kit Catalog Number
FS4-branded N12/IP54 cover with gasket, plastic plug, fans, Eaton logos	<b>FS4-N12KIT</b>
FS5-branded N12/IP54 cover with gasket, plastic plug, fans, Eaton logos	<b>FS5-N12KIT</b>
FS6-branded N12/IP54 cover with gasket, plastic plug, fans, Eaton logos	<b>FS6-N12KIT</b>

**Flange Kits**

The flange kit is used when the power section heat sink is mounted through the back panel of an enclosure.

**Flange Kit NEMA Type 1/IP21**

Includes flange, mounting brackets, and screws.

**Frames FS4–FS9** ①

Description	Catalog Number
<b>NEMA Type 1/IP21</b>	
FS4 N1/IP21 flange kit (fan not needed) (mounting N1 drive in N1 enclosure)	<b>FS4-Flange-N1KIT</b>
FS5 N1/IP21 flange kit (fan not needed) (mounting N1 drive in N1 enclosure)	<b>FS5-Flange-N1KIT</b>
FS6 N1/IP21 flange kit (fan not needed) (mounting N1 drive in N1 enclosure)	<b>FS6-Flange-N1KIT</b>
FS7 N1/IP21 flange kit (fan not needed) (mounting N1 drive in N1 enclosure)	<b>FS7-Flange-N1KIT</b>
FS8 N1/IP21 flange kit (fan not needed) (mounting N1 drive in N1 enclosure)	<b>FS8-Flange-N1KIT</b>
FS9 N1/IP21 flange kit (fan not needed) (mounting N1 drive in N1 enclosure)	<b>FS9-Flange-N1KIT</b>

**H-Max Series Drive Demo****Demos and Power Supply**

Description	Catalog Number
H-Max Series drive demo	<b>H-MAX-DEMO</b>
H-Max Series bypass demo	<b>H-MAX-BYPASS-DEMO</b>
Hand-held 24V auxiliary power supply—used to supply power to the control module in order to perform keypad programming before the drive is connected to line voltage	<b>9000XAUX24V</b>

**Notes**

- ① For installation of a NEMA Type 1 drive into a NEMA Type 1 oversized enclosure.
- ② For installation of a NEMA Type 1 drive into a NEMA Type 12 oversized enclosure.

**Flange Kit NEMA Type 12/IP54**

Includes flange, mounting brackets, NEMA Type 12 fan components, air shroud screws and plugs.

**Frames FS4–FS9** ②

Description	Catalog Number
<b>NEMA Type 12/IP54</b>	
FS4 N12/IP54 flange kit (mounting N1 drive into N12 enclosure)	<b>FS4-Flange-N12KIT</b>
FS5 N12/IP54 flange kit (mounting N1 drive into N12 enclosure)	<b>FS5-Flange-N12KIT</b>
FS6 N12/IP54 flange kit (mounting N1 drive into N12 enclosure)	<b>FS6-Flange-N12KIT</b>
FS7 N12/IP54 flange kit (mounting N1 drive into N12 enclosure)	<b>FS7-Flange-N12KIT</b>
FS8 N12/IP54 flange kit (mounting N1 drive into N12 enclosure)	<b>FS8-Flange-N12KIT</b>
FS9 N12/IP54 flange kit (mounting N1 drive into N12 enclosure)	<b>FS9-Flange-N12KIT</b>



## Replacement Parts

### Control Board/Keypad

Description	Current Catalog Number
Main H-Max Series control board, without relay board	<b>H-Max-Control Board</b>
H-Max Series graphic bypass, HOA	<b>KeypadbypassHOA</b>
H-Max Series graphic back, HOA	<b>KeypadbackHOA</b>
Remote keypad kits (includes bypass keypad overlay, N12 bezel, cables)	<b>OPTRMT-BP-Hmax</b>

### PC Cable

Description	Catalog Number
Remote download USB to RJ-45 cable with software driver disk	<b>REM-USB-Down</b>

### Replacement Relay Board in Slot B

Description	Catalog Number
Replacement relay board qty 2 Form C relay, qty 1 Form A relay	<b>Relay board 1</b>

### Fans

Description	Catalog Number
<b>230 Vac</b>	
FS4-230 Vac replacement fan	<b>FS4-Fan-230</b>
FS5-230 Vac replacement fan	<b>FS5-Fan-230</b>
FS6-230 Vac replacement fan	<b>FS6-Fan-230</b>
FS7-230 Vac replacement fan	<b>FS7-Fan-230</b>
FS8-230 Vac replacement fan	<b>FS8-Fan-230</b>
FS9-230 Vac replacement fan	<b>FS9-Fan-230</b>
<b>480 Vac</b>	
FS4-460 Vac replacement fan	<b>FS4-Fan-480</b>
FS5-460 Vac replacement fan	<b>FS5-Fan-480</b>
FS6-460 Vac replacement fan	<b>FS6-Fan-480</b>
FS7-460 Vac replacement fan	<b>FS7-Fan-480</b>
FS8-460 Vac replacement fan	<b>FS8-Fan-480</b>
FS9-460 Vac replacement fan	<b>FS9-Fan-480</b>

## Technical Data and Specifications

### H-Max Series Drives

Description	Specification
<b>Input Ratings</b>	
Input voltage ( $V_{in}$ )	200–240 Vac, 380–480 Vac, –10%/+10%
Input frequency ( $f_{in}$ )	50/60 Hz (variation up to 47–66 Hz)
Connection to power	Once per minute or less (typical operation)
Short circuit withstand rating	100 kAIC
<b>Output Ratings</b>	
Output voltage	0 to $V_{in}/U_{in}$ line voltage in
Continuous output current	Ambient temperature max. 104°F (40°C)
$I_L$ overload	1.1 x $I_L$ (1 min./10 min.)
Overload current	110% (1 min./10 min.)
Initial output current	150% for two seconds
Output frequency	0 to 320 Hz
Frequency resolution	0.01 Hz
<b>Control Characteristics</b>	
Control method	Frequency control (V/f) open loop sensorless vector control
Switching frequency	1–310 amps FS4–9: default 6 kHz
Frequency reference	Analog input: Resolution 0.1% (10-bit), accuracy $\pm 1\%$ Panel reference: Resolution 0.01 Hz
Field weakening point	8 to 320 Hz
Acceleration time	0.1 to 3000 seconds
Deceleration time	0.1 to 3000 seconds
Braking torque	DC brake: 30% x $T_n$ (without brake option)
<b>Ambient Conditions</b>	
Ambient operating temperature	FS4–FS9: 14°F (–10°C), no frost to 104°F (40°C) (Drive can operate at 122°F (50°C), see <b>Pages V6-T36-141</b> and <b>V6-T36-142</b> )
Storage temperature	–40° to 158°F (–40° to 70°C)
Relative humidity	0 to 95% RH, noncondensing, non-corrosive, no dripping water
Air quality	Chemical vapors: IEC 60721-3-3, unit in operation, Class 3C2; Mechanical particles: IEC 60721-3-3, unit in operation, Class 3S2
Altitude	100% load capacity (no derating) up to 3280 ft (1000m); 1% derating for each 328 ft (100m) above 3280 ft (1000m); max. 9842 ft (3000m); 380–480V
Vibration	FS4–FS9: EN 61800-5-1, EN 60068-2-6; 5 to 150 Hz, displacement amplitude 1 mm (peak) at 5 to 15.8 Hz, max. acceleration amplitude 1G at 15.8 to 150 Hz
Shock	EN 61800-5-1, EN 60068-2-27 UPS Drop test (for applicable UPS weights) Storage and shipping: max. 15G, 11 ms (in package)
Enclosure class	NEMA Type 1/IP21 or NEMA Type 12/IP54 (keypad required for IP54/Type 12)
<b>Standards</b>	
EMC	Immunity: Fulfills all EMC immunity requirements; Emissions: EN 61800-3, LEVEL H (EMC C2)
Emissions	EMC level dependent— +EMC 2: EN61800-3 (2004) Category C2 Delivered with Class C2 EMC filtering as default.

Description	Specification
<b>Control Connections</b>	
Analog input voltage	0 to 10V, R = 200 kohms differential Resolution 0.1%; Accuracy $\pm 1\%$ Dip switch selection (voltage/current)
Analog input current	0(4) to 20 mA; $R_i$ –250 ohms differential
Digital inputs (6)	Positive or negative logic; 18 to 30 Vdc
Auxiliary voltage	+24V $\pm 10\%$ , max. 250 mA
Output reference voltage	+10V +3%, max. load 10 mA
Analog output	0–10V, 0(4) to 20 mA; $R_L$ max. 500 ohms; Resolution 10 bit; Accuracy $\pm 2\%$ Dip switch selection (voltage/current)
Relay outputs	3 programmable, 2 Form C, 1 Form A relay outputs Switching capacity: 24 Vdc/8A, 250 Vac/8A, 125 Vdc/0.4A
Hard wire jumper	Between terminal 6 and 10 factory default
Dip switch setting default	RS485 = off A01 = current A12 = current A11 = voltage
<b>Protections</b>	
Overcurrent protection	Yes
Overvoltage protection	Yes
DC bus regulation anti-trip	Yes (accelerates or decelerates the load)
Undervoltage protection	Yes
Earth fault protection	Yes (in case of earth fault in motor or motor cable, only the frequency converter is protected)
Input phase supervision	Yes (trips if any of the input phases are missing)
Motor phase supervision	Yes (trips if any of the output phases are missing)
Overtemperature protection	Yes
Motor overload protection	Yes
Motor stall protection	Yes
Motor underload protection	Yes
Short circuit protection	Yes
Surge protection	Yes (varistor input)
Conformed coated (varnished) boards	Yes (prevents corrosion)
<b>Seismic</b>	
OHSPD Special Seismic Certification Pre-Approved	

## Wiring Diagram

## Control Input/Output, PID Application

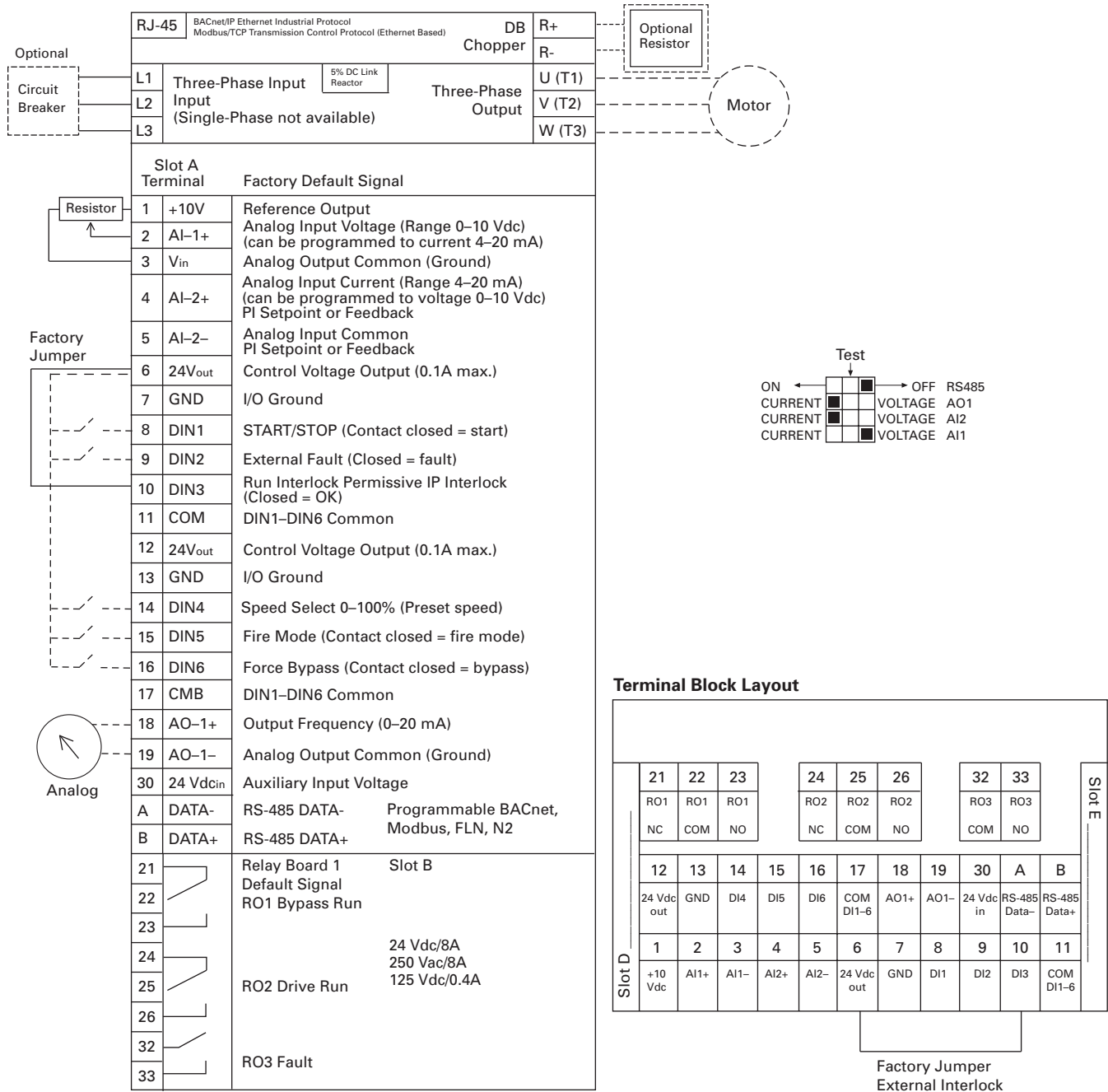
**Standards**

- Digital inputs D1–D6, relay out, analog in/out are freely programmed
- The user can assign a single input to multiple functions

**Includes**

- Six digital input
- Two analog input
- One analog output
- Three relay output
- RS-485
- Ethernet (BACnet and Modbus)

**Reliability**

- Pretested components
- Conformal coated (varnished) boards
- 40°C rated
- 110% overload for one minute
- Eaton Electrical Services & Systems national network of AF drive specialists

# 36.5

## Adjustable Frequency Drives

### H-Max Series Drives

#### Dimensions

Approximate Dimensions in Inches (mm)

36

#### H-Max Series Frames FS4-FS7

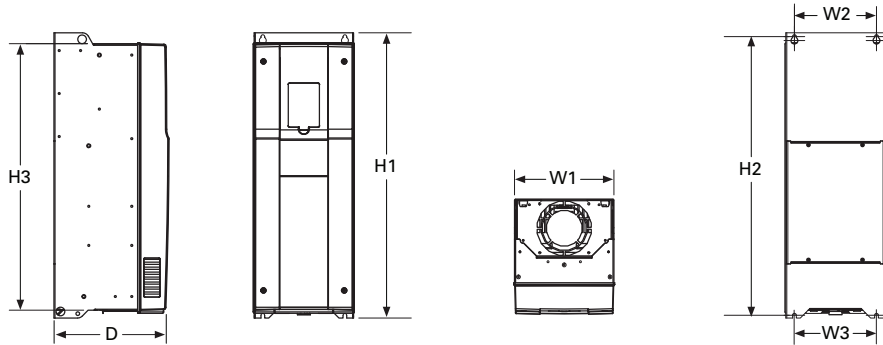

Voltage	hp	kW	Amps	D	H1	Hole Center-to-Center H2	H3	W1	W2	W3	Weight in Lbs (kg)
<b>FS4</b>											
230 Vac	0.75-4	0.55-3.0	3.7-12.5	7.77 (197.3)	12.89 (327.5)	12.32 (313.0)	11.22 (285.0)	5.04 (128.0)	3.94 (100.0)	3.94 (100.0)	13.2 (6)
480 Vac	1.5-7.5	1.1-5.5	3.4-12								
<b>FS5</b>											
230 Vac	5-10	4-7.5	18-31	8.73 (221.6)	16.50 (419.0)	15.98 (406.0)	15.04 (382.0)	5.67 (144.0)	4.53 (115.0)	3.94 (100.0)	22.0 (10)
480 Vac	10-20	7.5-15	16-31								
<b>FS6</b>											
230 Vac	15-20	11-15	48-62	9.29 (236.0)	21.93 (557.0)	21.28 (540.5)	20.24 (514.0)	7.68 (195.0)	5.83 (148.0)	5.83 (148.0)	44.1 (20)
480 Vac	25-40	18.5-30	38-61								
<b>FS7</b>											
230 Vac	25-30	18.5-30	75-105	10.49 (266.5)	25.98 (660.0)	25.39 (645.0)	24.29 (617.0)	9.06 (230.0)	7.48 (190.0)	7.48 (190.0)	82.6 (37.5)
480 Vac	50-75	37-55	72-105								

#### H-Max Series Frames FS8 and FS9

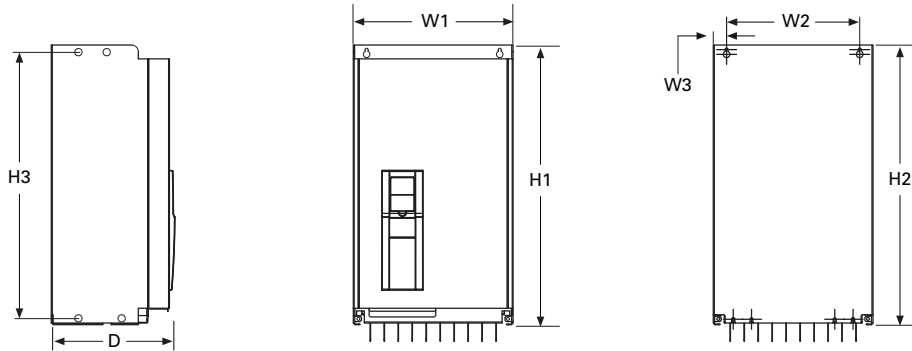

Voltage	hp	kW	Amps	D	H1	Hole Center-to-Center H2	H3	W1	W2	W3	Weight in Lbs (kg)
<b>FS8</b>											
230 Vac	50-75	37-55	140-205	13.76 (349.6)	38.02 (965.7)	37.26 (946.4)	37.26 (946.4)	11.42 (290.1)	9.29 (236.0)	1.42 (36.0)	154.3 (70)
480 Vac	100-150	75-110									
<b>FS9</b>											
230 Vac	100-120	75-90	261-310	14.63 (371.6)	33.09 (890.4)	31.89 (810.0)	31.89 (810.0)	18.90 (480.0)	15.75 (400.0)	1.57 (40.0)	238.1 (108)
480 Vac	200-250	132-160									

**Note:** For flange dimension, please reference User Manual.

## H-Max IntelliPass and IntelliDisconnect Drives



## Contents

<b>Description</b>	<b>Page</b>
H-Max Drives . . . . .	<b>V6-T36-139</b>
H-Max IntelliPass and IntelliDisconnect Drives	
Standards and Certifications . . . . .	<b>V6-T36-150</b>
Catalog Number Selection . . . . .	<b>V6-T36-150</b>
Product Selection . . . . .	<b>V6-T36-151</b>
H-Max IntelliPass/IntelliDisconnect . . . . .	<b>V6-T36-155</b>
Technical Data and Specifications . . . . .	<b>V6-T36-155</b>
Wiring Diagrams . . . . .	<b>V6-T36-156</b>
Dimensions . . . . .	<b>V6-T36-158</b>

## H-Max IntelliPass and IntelliDisconnect Drives

## Product Description

The IntelliPass electronic bypass is a two or optional three contactor design using a 24 Vdc **XT** Series contactor with an optional manual override switch that allows the unit to run in bypass without the H-Max Series drive.

The IntelliPass software parameters utilize engineering units common to the HVAC industry. Onboard startup wizard guarantees flawless commissioning with plug-and-play screen entry. Available in NEMA Type 1 and 12 with optional pre-engineered operator devices to meet all customized specification requirements.

The IntelliPass construction features allow for easy installation, reliable operation and serviceability with additional onboard wire space and removable conduit plates with knockouts.

## Features and Benefits

**IntelliPass/IntelliDisconnect**

- Circuit breaker provides flexible drive isolation configurations to meet customers' needs
- Communication interface enables control of the motor operated by the drive or bypass
- Plenum rated
- Designed and tested to UL 508C specifications
- Standard DC link choke for enhanced transient and harmonic distortion protection
- DC bus regulation anti-trip
- Input surge protection against voltage spikes varistor input
- EMI/RFI filters standard on all drives to meet EMC Category 2
- Top and bottom conduit entry for installation ease
- Pass-through I/O capability
- Additional I/O and communication cards provide plug and play functionality
- Copy/paste keypad function allows transfer of parameter settings from one drive to the next
- Optional fusing—fuse rating 200 kAIC

**IntelliPass**

- Keypad can display up to nine monitored parameters simultaneously
  - OHSPD Special Seismic Certification Pre-Approved
  - Standard NEMA Type 12 keypad on all drives
  - Simplified operating menu allows for typical programming changes
  - Accommodates a wide selection of expander boards and adapter boards
  - Control logic can be powered from an external auxiliary control panel
  - Standard I/O, 6 DI, 2 AI, 1 AO, 2 Form C RO, 1 Form A RO
  - Onboard RS-485 (Modbus, N2, FLN, BACnet)
  - Built-in Ethernet communication (BACnet/IP, Modbus/TCP)
  - DB chopper standard frames FS4–FS6 for USA application.
    - 1.5–40 hp, 2.1–52 amp, 480 Vac
    - 1–20 hp, 4.2–54 amp, 230 Vac
    - 1–20 hp, 4.6–60 amp, 208 Vac
  - Hard wired external/damper interlock
- Fully rated, mechanically interlocked contacts
  - HAND/OFF/AUTO and DRIVE/BYPASS selector on keypad simplifies control
  - Two power sources for control ensure redundancy and provide additional ride-through capability
  - Self-healing power supplies
  - Bypass circuit current interrupting rating up to 65 kAIC without fusing
  - Fully featured mechanically interlocked bypass featuring Eaton's **XT** contactors
  - Pre-engineered options to allow custom configurations (see option P150)
  - Robust steel enclosure for simple installation
  - Programmable auto restart and auto bypass while allowing critical damper interlock functionality

# 36.5

## Adjustable Frequency Drives

### H-Max Series Drives

36

#### Standards and Certifications

##### Product

- IEC 61800-5-1
- CE
- cUL

##### Safety

- UL 508C
- EN 61800-5-1
- CE
- cUL



- OHSPD Special Seismic Certification Pre-Approved

#### Catalog Number Selection

##### H-Max Series IntelliPass and IntelliDisconnect Drives

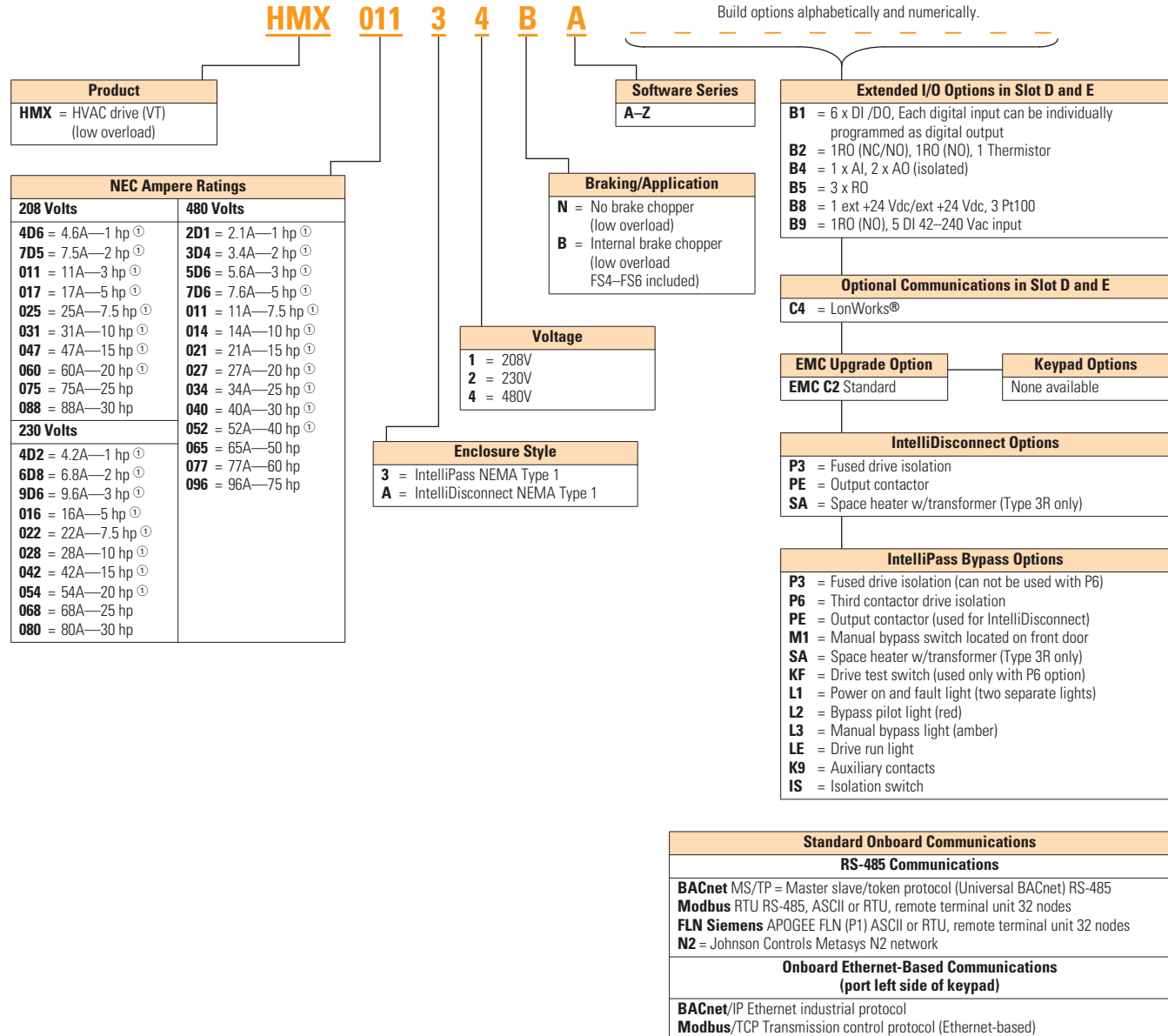

#### Notes

IntelliPass—two contactor electronic bypass standard.  
 All boards are varnished. Corrosion resistant.  
 Battery included in all drives for real-time clock. Three year lifetime.

Keypad kit includes HOA bypass. EMI/RFI filters included.  
 DC link choke included.

① DB chopper standard frames FS4–FS6 for USA application. 1.5–40 hp, 2.1–52 amp, 480 Vac; 1–20 hp, 4.2–54 amp, 230 Vac; 1–20 hp, 4.6–60 amp, 208 Vac.

## Product Selection

*H-Max Series IntelliPass NEMA Type 1—Two Contactor Bypass Standard*

HMX\_



## 208 Vac

FS Frame Size	Horsepower	Drive Rated NEC Amps	Catalog Number
4	1	4.6	HMX4D631BA
	2	7.5	HMX7D531BA
	3	10.6	HMX01131BA
5	5	16.7	HMX01731BA
	7.5	24.2	HMX02531BA
	10	30.8	HMX03131BA
6	15	46.2	HMX04731BA
	20	59.4	HMX06031BA
7	25	74.9	HMX07531NA
	30	88	HMX08831NA

## 230 Vac

FS Frame Size	Horsepower	Drive Rated NEC Amps	Catalog Number
4	1	4.2	HMX4D232BA
	2	6.8	HMX6D832BA
	3	9.6	HMX9D632BA
5	5	15.2	HMX01632BA
	7.5	22	HMX02232BA
	10	28	HMX02832BA
6	15	42	HMX04232BA
	20	54	HMX05432BA
7	25	68	HMX06832NA
	30	80	HMX08032NA

## 480 Vac

FS Frame Size	Horsepower	Drive Rated NEC Amps	Catalog Number
4	1	2.1	HMX2D134BA
	2	3.4	HMX3D434BA
	3	5.6	HMX5D634BA
	5	9.6	HMX7D634BA
	7.5	11	HMX01134BA
5	10	14	HMX01434BA
	15	21	HMX02134BA
	20	27	HMX02734BA
6	25	34	HMX03434BA
	30	40	HMX04034BA
	40	52	HMX05234BA
7	50	65	HMX06534NA
	60	77	HMX07734NA
	75	96	HMX09634NA

**H-Max Series IntelliDisconnect NEMA Type 1—Main Disconnect Standard**

36

HMX

**208 Vac**

FS Frame Size	Horsepower	Drive Rated NEC Amps	Catalog Number
4	1	4.6	HMX4D6A1BA
	2	7.5	HMX7D5A1BA
	3	11	HMX011A1BA
5	5	17	HMX017A1BA
	7.5	25	HMX025A1BA
	10	31	HMX031A1BA
6	15	47	HMX047A1BA
	20	60	HMX060A1BA
7	25	75	HMX075A1NA
	30	88	HMX088A1NA

**230 Vac**

FS Frame Size	Horsepower	Drive Rated NEC Amps	Catalog Number
4	1	4.2	HMX4D2A2BA
	2	6.8	HMX6D8A2BA
	3	9.6	HMX9D6A2BA
5	5	15.2	HMX016A2BA
	7.5	22	HMX022A2BA
	10	28	HMX028A2BA
6	15	42	HMX042A2BA
	20	54	HMX054A2BA
7	25	68	HMX068A2NA
	30	80	HMX080A2NA

**480 Vac**

FS Frame Size	Horsepower	Drive Rated NEC Amps	Catalog Number
4	1	2.1	HMX2D1A4BA
	2	3.4	HMX3D4A4BA
	3	5.6	HMX5D6A4BA
	5	9.6	HMX7D6A4BA
	7.5	11	HMX011A4BA
5	10	14	HMX014A4BA
	15	21	HMX021A4BA
	20	27	HMX027A4BA
6	25	34	HMX034A4BA
	30	40	HMX040A4BA
	40	52	HMX052A4BA
7	50	65	HMX065A4NA
	60	77	HMX077A4NA
	75	96	HMX096A4NA

**Note**For Wiring Diagrams, see **Page V6-T36-157**.



**Onboard Network Communications****Johnson Controls Metasys N2**

H-Max Series provides communication between the drive and a Johnson Controls Metasys™ N2 network. With this connection, the drive can be controlled, monitored and programmed from the Metasys system. N2 can be selected and programmed by the drive keypad.

**BACnet**

H-Max Series provides communication to BACnet networks. Data transfer is master-slave/token passing (MS/TP) RS-485.

**BACnet IP**

100 base T interface.

**Modbus TCP**

Ethernet based protocol.

**Modbus RTU**

H-Max Series provides communication to Modbus RTU RS-485 as a slave on a Modbus network. Other communication parameters include an address range from 1–247; a parity of None, Odd or Even; and the stop bit is 1.

**FLN**

H-Max Series provides communication to Siemens APOGEE™ FLN (P1) RTU RS-485 as a slave on an FLN network. Other communication parameters include an address range from 1–247, a parity of None, Odd or Even and option boards.

**H-Max Series Option Board Kits Available for Slots D and E**

The H-Max Series drives can accommodate a wide selection of expander and adapter option boards to customize the drive for your

application needs. The drive's control unit is designed to accept a total of two option boards.

The H-Max Series factory-installed standard board configuration includes an I/O board and a relay output board.

**Option Boards Mounted in Slots D and E**

Option Kit Description	Option Kit Catalog Number
6 x DI /DO, each digital input can be individually programmed as digital output	<b>XXM-IO-B1-A</b>
1RO Form C (NO/NC), 1RO Form A (NO), 1 thermistor	<b>XXM-IO-B2-A</b>
1 x AI, 2 x AO (isolated)	<b>XXM-IO-B4-A</b>
3 x RO Form A (NO)	<b>XXM-IO-B5-A</b>
1 ext +24 Vdc/ext +24 Vdc, 3 Pt100	<b>XXM-IO-B8-A</b>
1RO Form A (NO), 5DI 42–240 Vac input	<b>XXM-IO-B9-A</b>
LonWorks®	<b>XXM-COM-C4-A</b>

**NEMA Type 12/IP54 Conversion Kit**

The NEMA Type 12/IP54 option kit is used to convert a NEMA Type 1 to a NEMA Type 12 drive.

Kit consists of a drive cover, fan kit and plugs.

**NEMA Type 12/IP54 Cover**

Option Kit Description	Option Kit Catalog Number
FS4-branded N12/IP54 cover with gasket, plastic plug, fans, Eaton logos	<b>FS4-N12KIT</b>
FS5-branded N12/IP54 cover with gasket, plastic plug, fans, Eaton logos	<b>FS5-N12KIT</b>
FS6-branded N12/IP54 cover with gasket, plastic plug, fans, Eaton logos	<b>FS6-N12KIT</b>
FS7-branded N12/IP54 cover with gasket, plastic plug, fans, Eaton logos	<b>FS7-N12KIT</b>
FS8-branded N12/IP54 cover with gasket, plastic plug, fans, Eaton logos	<b>FS8-N12KIT</b>
FS9-branded N12/IP54 cover with gasket, plastic plug, fans, Eaton logos	<b>FS9-N12KIT</b>

#### Third Contactor Drive Isolation

Horsepower at 208 and 230 Vac	Suffix Number <sup>①②</sup>
1-3	P6
5-7.5	P6
10	P6
15	P6
20	P6
25	P6
30	P6

Horsepower at 480 Vac	Suffix Number <sup>①②</sup>
1-7.5	P6
10-15	P6
20	P6
25	P6
30	P6

Horsepower at 480 Vac	Suffix Number <sup>①②</sup>
40	P6
50	P6
60	P6
75	P6

#### Drive Isolation Service Switch

Horsepower at 208 and 230 Vac	Suffix Number <sup>①</sup>
1-3	IS
5-7.5	IS
10	IS
15	IS
20	IS
25	IS
30	IS

Horsepower at 480 Vac	Suffix Number <sup>①</sup>
1-7.5	IS
10-15	IS
20	IS
25	IS
30	IS

Horsepower at 480 Vac	Suffix Number <sup>①</sup>
40	IS
50	IS
60	IS
75	IS

#### Output Contactor Used for IntelliDisconnect

Horsepower at 208 and 230 Vac	Suffix Number <sup>①③</sup>
1-3	PE
5-7.5	PE
10	PE
15	PE
20	PE
25	PE
30	PE

Horsepower at 480 Vac	Suffix Number <sup>①③</sup>
1-7.5	PE
10-15	PE
20	PE
25	PE
30	PE

Horsepower at 480 Vac	Suffix Number <sup>①③</sup>
40	PE
50	PE
60	PE
75	PE

#### Auxiliary Contacts

Horsepower at 208/230 Vac	Description	Suffix Number <sup>④</sup>
1-30	Factory installed	K9

Horsepower at 480 Vac	Description	Suffix Number <sup>④</sup>
1-75	Factory installed	K9

#### Optional Operator Devices

Description	Suffix Number <sup>④</sup>
Bypass test switch (used with third contactor isolation switch)	KF
Power on (green), fault (red) pilot lights	L1
Bypass (red) pilot light	L2

Description	Suffix Number <sup>④</sup>
Manual bypass light (amber)	L3
Drive run (red) pilot light	LE
Manual bypass switch located on door	M1

#### Drive Isolation Input Fusing

Horsepower at 208 and 230 Vac	Suffix Number <sup>①②</sup>
1-3	P3
5-7.5	P3
10	P3
15	P3
20	P3
25	P3
30	P3

Horsepower at 480 Vac	Suffix Number <sup>①②</sup>
1-7.5	P3
10-15	P3
20	P3
25	P3
30	P3

Horsepower at 480 Vac	Suffix Number <sup>①②</sup>
40	P3
50	P3
60	P3
75	P3

#### Notes

- ① Fused drive isolation (P3) and third contactor (P6) or drive isolation switch (IS) cannot be installed together.
- ② P6 option not available with IntelliDisconnect.
- ③ PE option only available with IntelliDisconnect.
- ④ K9 option only available with IntelliPass drives.

## H-Max IntelliPass/IntelliDisconnect

### Primary Design Features

Description	IntelliPass	IntelliDisconnect
CB MMP	Standard	Standard
2 contactor bypass	Standard	N/A
Mechanical interlock	Standard	N/A
Electrical interlock	Standard	N/A
Third contactor (isolation)	Optional	N/A

## Technical Data and Specifications

### H-Max Series Drives

Description	Specification
<b>Input Ratings</b>	
Input voltage ( $V_{in}$ )	208, 230, 480 Vac, $-10\%/+10\%$
Input frequency ( $f_{in}$ )	50/60 Hz (variation up to 47–66 Hz)
Connection to power	Once per minute or less (typical operation)
Short circuit withstand rating	65 kAIC combination
<b>Output Ratings</b>	
Output voltage	0 to $V_{in}/U_{in}$ line voltage in
Continuous output current	Ambient temperature max. 104°F (40°C)
$I_L$ overload	1.1 x $I_L$ (1 min./10 min.)
Overload current	110% (1 min./10 min.)
Initial output current	150% for two seconds
Output frequency	0 to 320 Hz
Frequency resolution	0.01 Hz
<b>Control Characteristics</b>	
Control method	Frequency control (V/f) open loop sensorless vector control
Switching frequency	1–310 amps; adjustable with parameter 2.6.9 FS4–FS7: default 6 kHz
Frequency reference	Analog input: Resolution 0.1% (10-bit), accuracy $\pm 1\%$ Panel reference: Resolution 0.01 Hz
Field weakening point	8 to 320 Hz
Acceleration time	0.1 to 3000 seconds
Deceleration time	0.1 to 3000 seconds
Braking torque	DC brake: 30% x $T_n$ (without brake option)
<b>Ambient Conditions</b>	
Ambient operating temperature	FS4–FS7: 14°F (–10°C), no frost to 104°F (40°C) (Drive can operate at 122°F (50°C))
Storage temperature	–40° to 158°F (–40° to 70°C)
Relative humidity	0 to 95% RH, noncondensing, non-corrosive, no dripping water
Air quality	Chemical vapors: IEC 60721-3-3, unit in operation, Class 3C2; Mechanical particles: IEC 60721-3-3, unit in operation, Class 3S2
Altitude	100% load capacity (no derating) up to 3280 ft (1000m); 1% derating for each 328 ft (100m) above 3280 ft (1000m); max. 9842 ft (3000m); 380–480V
Vibration	FS4–FS7: EN 61800-5-1, EN 60068-2-6; 5 to 150 Hz, displacement amplitude 1 mm (peak) at 5 to 15.8 Hz, max. acceleration amplitude 1G at 15.8 to 150 Hz
Shock	EN 61800-5-1, EN 60068-2-27 UPS Drop test (for applicable UPS weights) Storage and shipping: max. 15G, 11 ms (in package)
Enclosure class	NEMA Type 1/IP21 or NEMA Type 12/IP54 (keypad required for IP54/Type 12)

Description	IntelliPass	IntelliDisconnect
Isolation switch	Optional	N/A
Top entry (power)	Standard	Standard
Bottom entry (power)	Standard	Standard
Output contactor	Standard	Optional

Description	Specification
<b>Standards</b>	
EMC	Immunity: Fulfills all EMC immunity requirements; Emissions: EN 61800-3, LEVEL H (EMC C2)
Emissions	EMC level dependent— +EMC 2: EN61800-3 (2004) Category C2 Delivered with Class C2 EMC filtering as default.
<b>Control Connections</b>	
Analog input voltage	0 to 10V, R = 200 kohms differential Resolution 0.1%; Accuracy $\pm 1\%$ Dip switch selection (voltage/current)
Analog input current	0(4) to 20 mA; $R_i$ –250 ohms differential
Digital inputs (6)	Positive or negative logic; 18 to 30 Vdc
Auxiliary voltage	+24V $\pm 10\%$ , max. 250 mA
Output reference voltage	+10V +3%, max. load 10 mA
Analog output	0–10V, 0(4) to 20 mA; $R_L$ max. 500 ohms; Resolution 10 bit; Accuracy $\pm 2\%$ ; Dip switch selection (voltage/current)
Relay outputs	3 programmable, 2 Form C, 1 Form A relay outputs Switching capacity: 24 Vdc/8A, 250 Vac/8A, 125 Vdc/0.4A
Hard wire jumper	Between terminal 6 and 10 factory default
Dip switch setting default	RS485 = off A01 = current A12 = current A11 = voltage
<b>Protections</b>	
Overcurrent protection	Yes
Overvoltage protection	Yes
DC bus regulation anti-trip	Yes (accelerates or decelerates the load)
Undervoltage protection	Yes
Earth fault protection	Yes (in case of earth fault in motor or motor cable, only the frequency converter is protected)
Input phase supervision	Yes (trips if any of the input phases are missing)
Motor phase supervision	Yes (trips if any of the output phases are missing)
Overtemperature protection	Yes
Motor overload protection	Yes
Motor stall protection	Yes
Motor underload protection	Yes
Short circuit protection	Yes
Surge protection	Yes (varistor input)
Conformed coated (varnished) board	Yes (prevents corrosion)
<b>Seismic</b>	
OHSPD Special Seismic Certification Pre-Approved	

#### Wiring Diagrams

#### Control Input/Output, PID Application

36

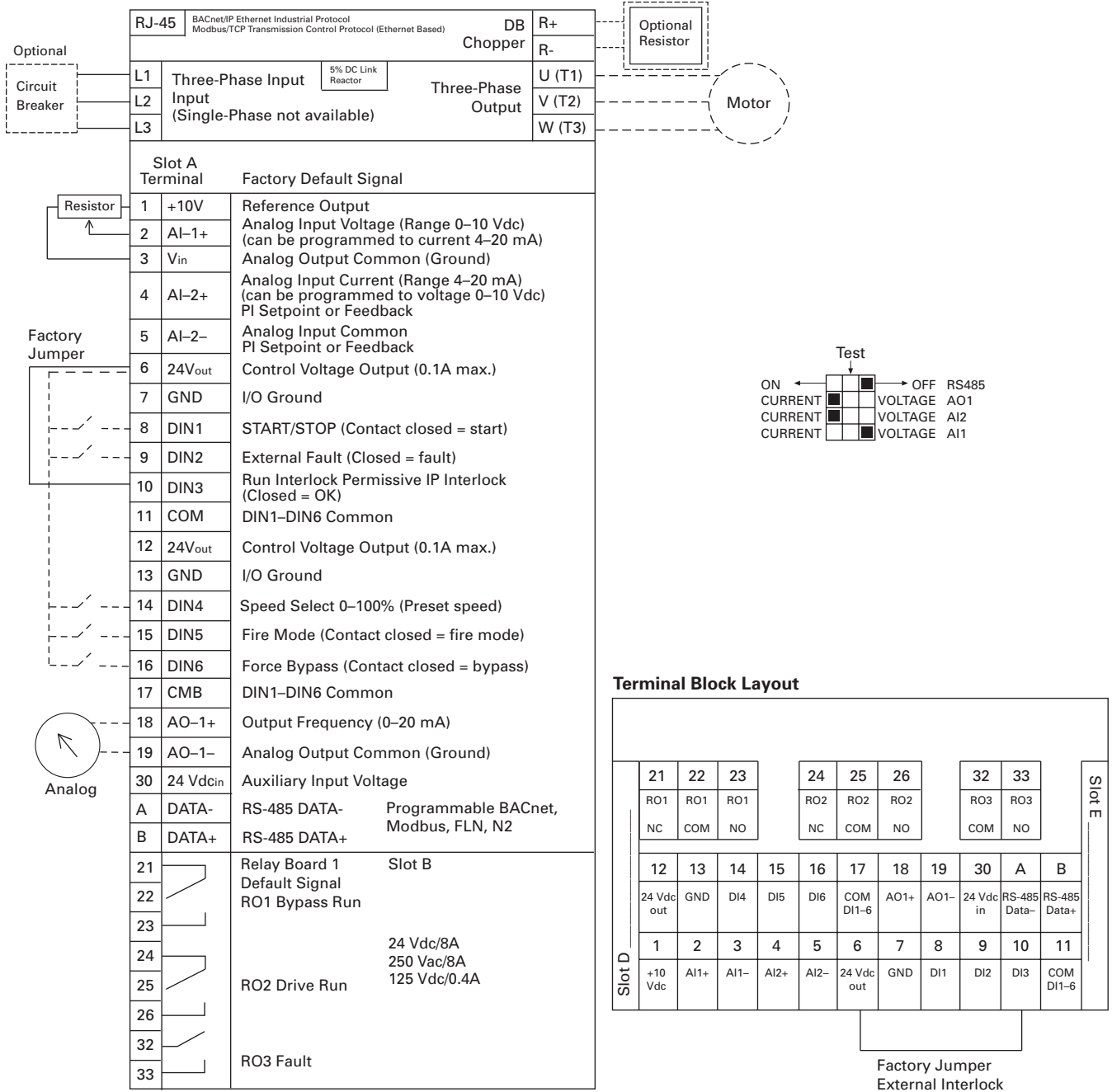

#### Standards

- Digital inputs D1–D6, relay out, analog in/out are freely programmed
- The user can assign a single input to multiple functions

#### Includes

- Six digital input
- Two analog input
- One analog output
- Three relay output
- RS-485
- Ethernet

#### Reliability

- Pretested components
- Conformal coated (varnished) boards
- 40°C rated
- 110% overload for one minute
- Eaton Electrical Services & Systems national network of AF drive specialists

## H-Max Series IntelliPass

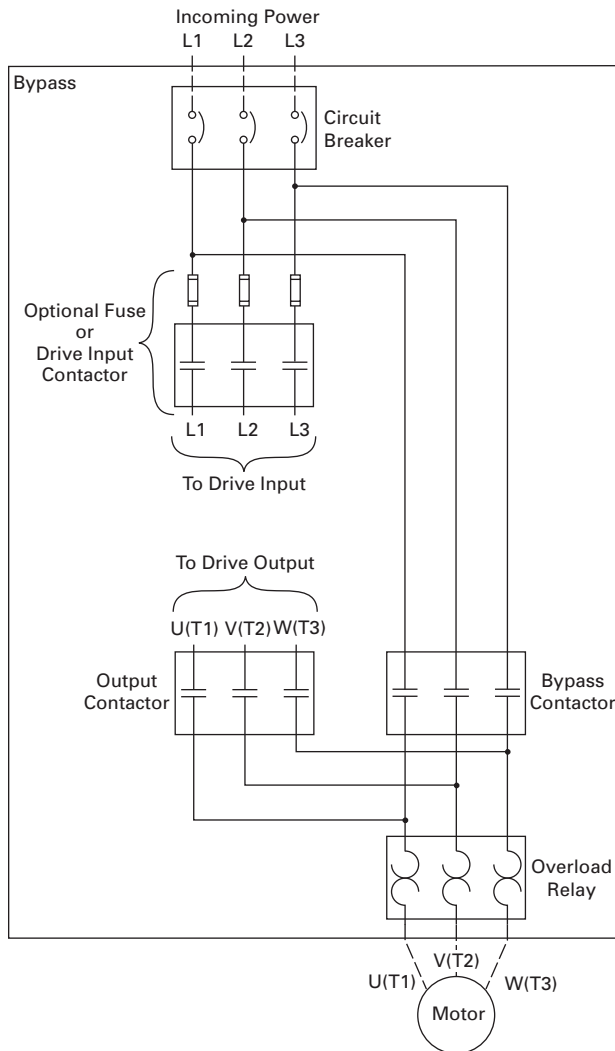

## H-Max Series IntelliDisconnect Power Wiring

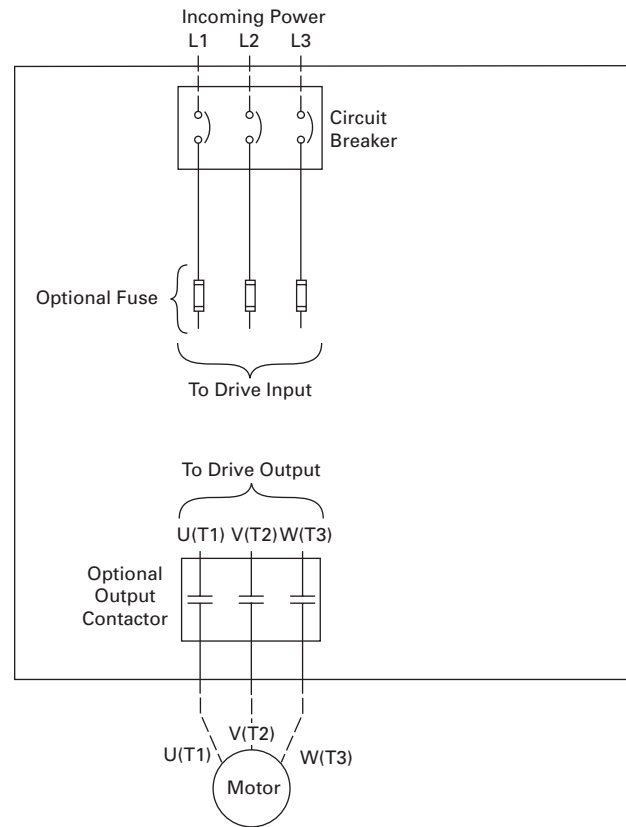

# 36.5

## Adjustable Frequency Drives

### H-Max Series Drives

#### Dimensions

Approximate Dimensions in Inches (mm)

#### 36 H-Max Series IntelliPass and IntelliDisconnect Drives

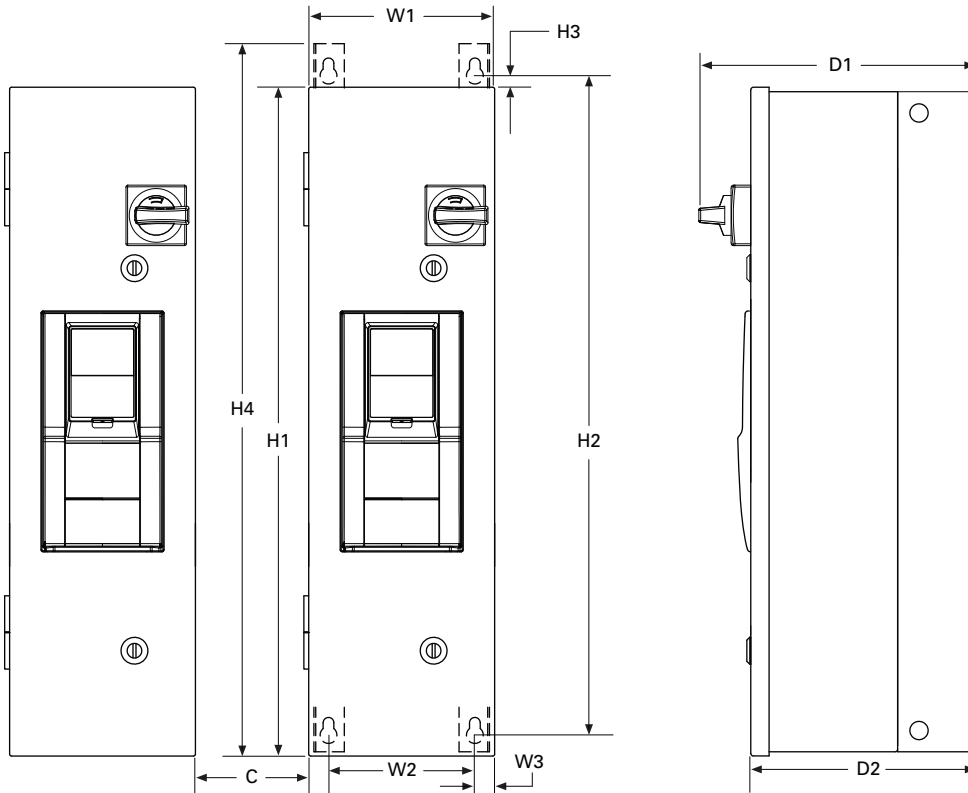

Consult factory or use manual for final dimensions.

Frame Size	Voltage	Horsepower (I <sub>L</sub> )	H1	H2	H3	H4	C	W1	W2	W3	D1	D2	Weight in Lbs (kg)
FS4	208	1–3	29.69	37.12	0.25	31.00	3.00	7.88	6.33	0.75	11.40	9.27	45 (20.41)
	230	1–3	(754.1)	(942.9)	(6.35)	(914.4)	(76.2)	(200.2)	(160.8)	(19.1)	(289.6)	(235.5)	
	480	1–7.5											
FS5	208	5–10	37.00	34.47	0.25	38.31	3.00	9.40	7.75	0.75	15.30	13.17	57.5 (26.10)
	230	5–10	(939.8)	(875.5)	(6.35)	(973.0)	(76.2)	(238.8)	(196.9)	(19.1)	(388.6)	(334.6)	
	480	10–20											
FS6	208	15–20	45.08	40.28	0.25	46.4	4.00	10.90	9.35	0.75	15.75	13.62	98.0 (44.45)
	230	15–20	(1145.0)	(1023.1)	(6.35)	(1178.6)	(101.6)	(276.9)	(327.5)	(19.1)	(400.0)	(346.0)	
	480	25–40											
FS7	208	25–30	58.32	56.30	0.25	59.46	5.00	13.98	12.35	0.75	15.50	13.55	165.0 (74.84)
	230	25–30	(1481.3)	(1430.0)	(6.35)	(1510.3)	(127.0)	(355.1)	(313.7)	(19.1)	(393.7)	(244.2)	
	480	50–75											

**Note:** C distance is spacing required to mount multiple drives.

## CFX9000 Enclosed Drives



## Product Description

The CFX9000 Clean Power Drives from Eaton's electrical sector use tuned passive filters to significantly reduce line harmonics at the drive input terminals.

The CFX9000 drive also delivers True Power Factor—in addition to reducing harmonic distortion, the CFX9000 drive prevents transformer overheating and overloading of breakers and feeders, which enables the application of adjustable frequency drives on generators and other high impedance power systems.

The 9000X family of drives includes HVX9000, SVX9000, SLX9000, and SPX9000. 9000X Series drive ratings are rated for either high overload ( $I_H$ ) or low overload ( $I_L$ ).  $I_L$  indicates 110% overload capacity for 1 minute out of 10 minutes.  $I_H$  indicates 150% overload capacity for 1 minute out of 10 minutes.

## Contents

<b>Description</b>	<b>Page</b>
CFX9000 Drives	
Application Description . . . . .	<b>V6-T36-160</b>
Features and Benefits . . . . .	<b>V6-T36-166</b>
Standards and Certifications . . . . .	<b>V6-T36-166</b>
Product Identification . . . . .	<b>V6-T36-166</b>
Catalog Number Selection . . . . .	<b>V6-T36-167</b>
Product Selection . . . . .	<b>V6-T36-168</b>
Options . . . . .	<b>V6-T36-175</b>
Technical Data and Specifications . . . . .	<b>V6-T36-180</b>
Wiring Diagram . . . . .	<b>V6-T36-182</b>
Dimensions . . . . .	<b>V6-T36-183</b>

## CFX9000 Enclosed Products

- **Standard Enclosed**—covers a wide range of the most commonly ordered options. Pre-engineering eliminates the lead time normally associated with customer specific options. Available configurations are listed on **Pages V6-T36-166 to V6-T36-181**.
- **Modified Standard Enclosed**—applies to specific customer requirements that vary from the Standard Enclosed offering, such as the need for an additional indicating light or minor modifications to drawings. *Contact your local sales office for assistance in pricing and lead time.*
- **Custom Engineered**—for those applications with more unique or complex requirements, these are individually engineered to the customer's needs. *Contact your local sales office for assistance in pricing and lead time.*

## Application Description

Designed to meet the IEEE® 519-1992 requirements for harmonic distortion, the CFX9000 is an excellent

choice for small and midsize drives applications where harmonics are a concern.

## What Are Harmonics?

**Take a perfect wave with a fundamental frequency of 60 Hz, which is close to what is supplied by the power company.**

### Perfect Wave

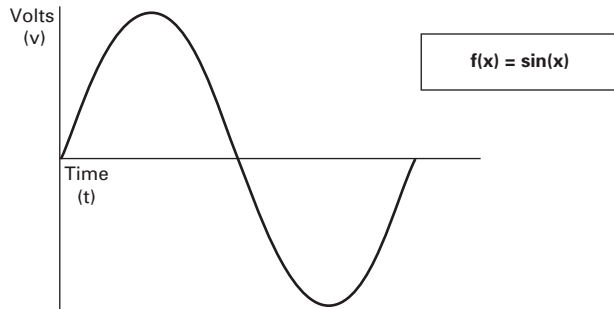

**Add a second wave that is five times the fundamental frequency—300 Hz (typical of frequency added to the line by a fluorescent light).**

### Second Wave

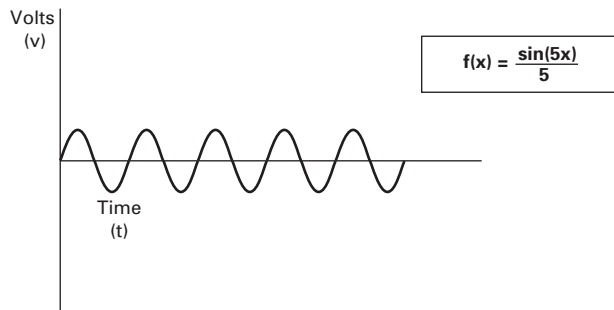

**Combine the two waves. The result is a 60 Hz supply rich in fifth harmonics.**

### Resulting Supply

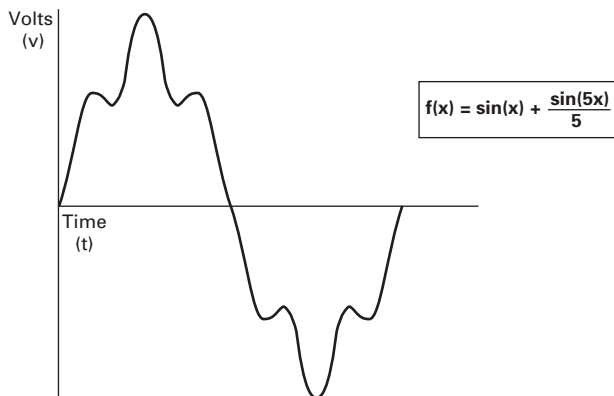

## What Causes Harmonics?

Harmonics are the result of nonlinear loads that convert AC line voltage to DC. Examples of equipment that are non-linear loads are listed below:

- AC variable frequency drives
- DC drives
- Fluorescence lighting, computers, UPS systems
- Industrial washing machines, punch presses, welders, etc.

## How Can Harmonics Due to VFDs Be Diminished?

By applying drives from the Eaton Clean Power Drives Family; The HCX9000, CFX9000 and CPX9000.

## What Are Linear Loads?

Linear loads are primarily devices that run across the line and do not add harmonics. Motors are prime examples. The downside to having large motor linear loads is that they draw more energy than a VFD, because of their inability to control motor speed. In most applications there is a turn down valve used with the motor which will reduce the flow of the material, without significantly reducing the load to the motor. While this provides some measure of speed control, it is extremely inefficient.

## Why Be Concerned About Harmonics?

1. **Installation and utility costs increase.** Harmonics cause damage to transformers and lower efficiencies due to the IR loss. These losses can become significant (from 16.6–21.6%) which can have a dramatic effect on the HVAC systems that are controlling the temperatures of the building where the transformer and drive equipment reside.
2. **Downtime and loss of productivity.** Telephones and data transmissions links may not be guaranteed to work on the same power grids polluted with harmonics.
3. **Downtime and nuisance trips of drives and other equipment.** Emergency generators have up to three times the impedance that is found in a conventional utility source. Thus the harmonic voltage can be up to three times as large, causing risk of operation problems.
4. **Larger motors must be used.** Motors running across the line that are connected on polluted power distribution grids can overheat or operate at lower efficiency due to harmonics.
5. **Higher installation costs.** Transformers and power equipment must be oversized to accommodate the loss of efficiencies. This is due to the harmonic currents circulating through the distribution without performing useful work.



### How Does a VFD Convert Three-Phase AC to a Variable Output Voltage and Frequency?

The six-pulse VFD: The majority of all conventional drives that are built consist of a six-pulse configuration. The figure below represents a six-diode rectifier design that converts three-phase utility power to DC. The inverter section uses IGBTs to convert DC power to a simulated AC sine wave that can vary in frequency from 0–400 Hz.

The six-pulse VFD drive creates harmonic current distortion. The harmonic current that is created is energy that can not be used by customers and causes external heat and losses to all components including other drives that are on the same power distribution. The figure is a 100 hp drive with 45A of damaging harmonic current.

#### 100 hp Six-Diode Rectifier Design

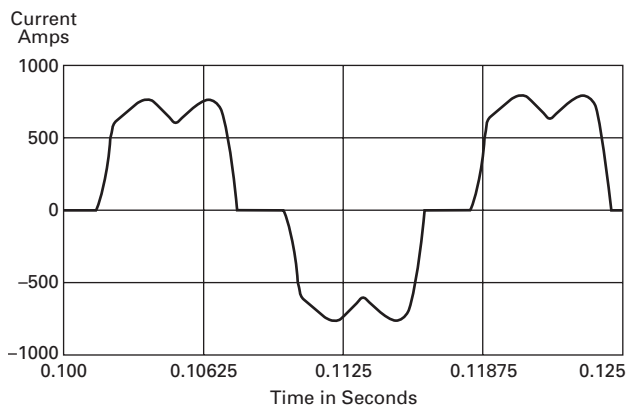

#### 100 hp Six-Pulse Nonproductive Harmonic Current

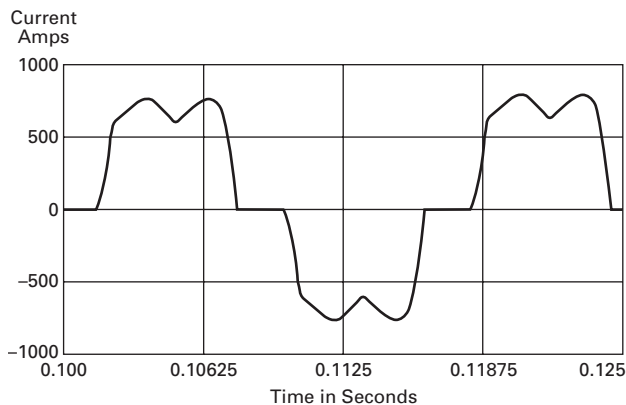

#### Six-Pulse Nonproductive Harmonic Current

##### Six-Pulse Circuit

Current harmonics

$I_1 = 100\%$        $I_{11} = 6.10\%$        $I_{19} = 1.77\%$

$I_5 = 22.5\%$        $I_{13} = 4.06\%$        $I_{23} = 1.12\%$

$I_7 = 9.38\%$        $I_{17} = 2.26\%$        $I_{25} = 0.86\%$

Power = 100 hp

Harmonic current = 45 amps

### Guidelines of Meeting IEEE Std. 519-1992 Harmonic Distortion Limits

The IEEE 519-1992 Specification is a standard that provides guidelines for commercial and industrial

users that are implementing medium and low voltage equipment.

#### Maximum Harmonic Current Distortion in % of the Fundamental (120V through 69,000V)

I <sub>sc</sub> /I <sub>L</sub>	Harmonic Order (Odd Harmonics)					TDD
	h<11	11≤h<17	17≤h<23	23≤h<35	35≤h	
<20	4.0	2.0	1.5	0.6	0.3	5.0
20-50	7.0	3.5	2.5	1.0	0.5	8.0
50-100	10.0	4.5	4.0	1.5	0.7	12.0
100-1000	12.0	5.5	5.0	2.0	1.0	15.0
>1000	15.0	7.0	6.0	2.5	1.4	20.0

*The ratio I<sub>sc</sub>/I<sub>L</sub> is the ratio of the short-circuit current available at the point of common coupling (PCC), to the maximum fundamental load current. Consequently, as the size of the user load decreases with respect to the size of the system, the percentage of harmonic current that the user is allowed to inject into the utility system increases.*

##### Notes

TDD = Total demand distortion is the harmonic current distortion in percent of the maximum demand load current (15 or 30 minute demand).

I<sub>sc</sub> = Maximum short circuit current at the PCC not counting motor contribution.

I<sub>L</sub> = Maximum demand load current for all of the connected loads (fundamental frequency component) at the PCC. All of the limits are measured at a point of common coupling.

#### One-Line Diagram for Harmonic Analysis

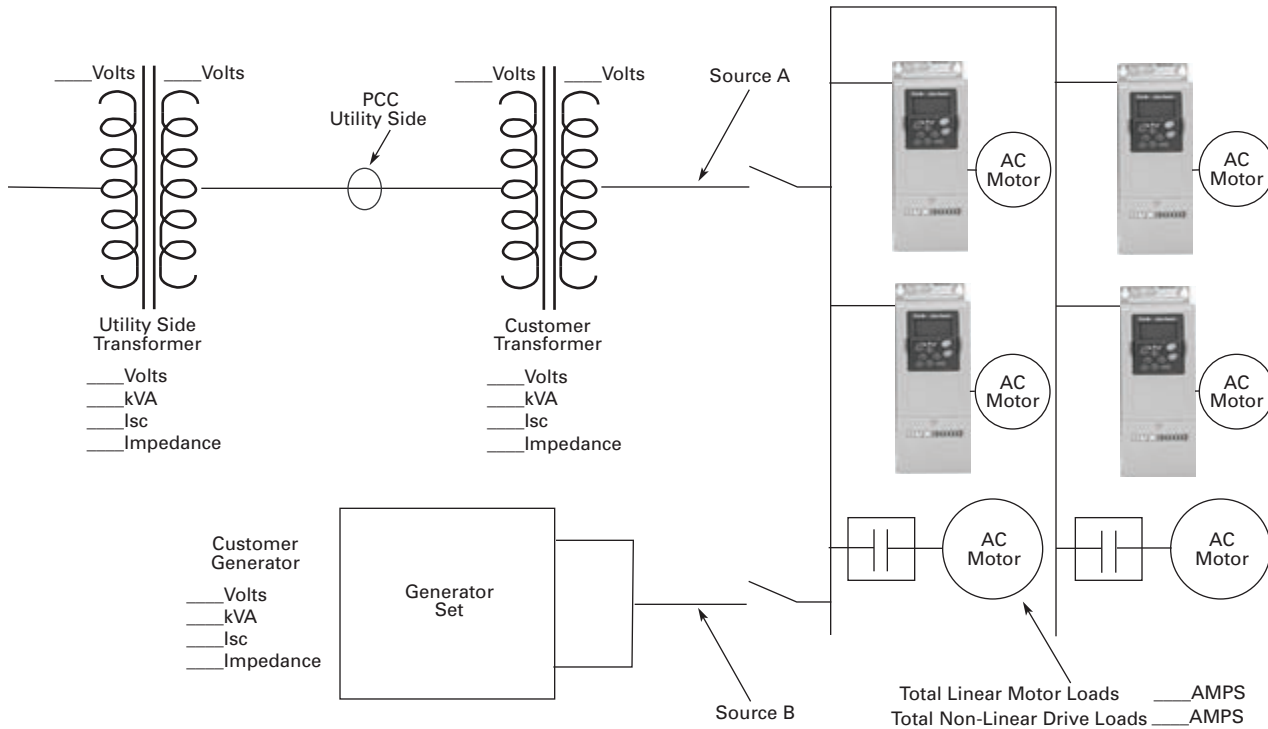

**The best way to estimate AFD harmonic contribution to an electrical system is to perform a harmonic analysis based on known system characteristics. The one line in this figure would provide the data to complete the calculations.**

#### Terms

- PCC (Point of Common Coupling) is defined as the electrical connecting point between the utility and multiple customers per the specifications in IEEE 519
- POA (Point of Analysis) is defined as where the harmonic calculations are taken

An oscilloscope can make all measurements at the PCC or POA to do an on-site harmonic evaluation.

#### Harmonic Reduction Methods to Meet IEEE 519

##### 1. Line Reactor

A line reactor is a three-phase series inductance on the line side of an AFD. If a line reactor is applied on all AFDs, it is possible to meet IEEE guidelines where 10–25% of system loads are AFDs, depending on the stiffness of the line and the value of line reactance. Line reactors are available in various values of percent impedance, most typically 1–1.5%, 3% and 5%.

**Note:** The 9000X drives come standard with a nominal 3% input impedance.)

#### Line Reactor

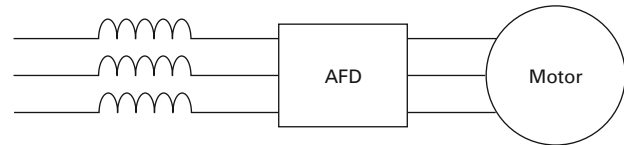

#### Advantages

- Low cost
- Can provide moderate reduction in voltage and current harmonics
- Available in various values of percent impedance
- Provides increased input protection for AFD and its semiconductors from line transients

#### Disadvantages

- May not reduce harmonic levels to below IEEE 519-1992 guidelines
- Voltage drop due to IR loss

## 2. Passive Filters

Tuned harmonic filters involve the series connection of an inductor with the shunt connection of an inductor and capacitor to form a low impedance path to ground for

a specific range of frequencies. This path presents an alternative to the flow of harmonic currents back into the utility source.

### CFX9000 Drive with Integrated Passive Filter

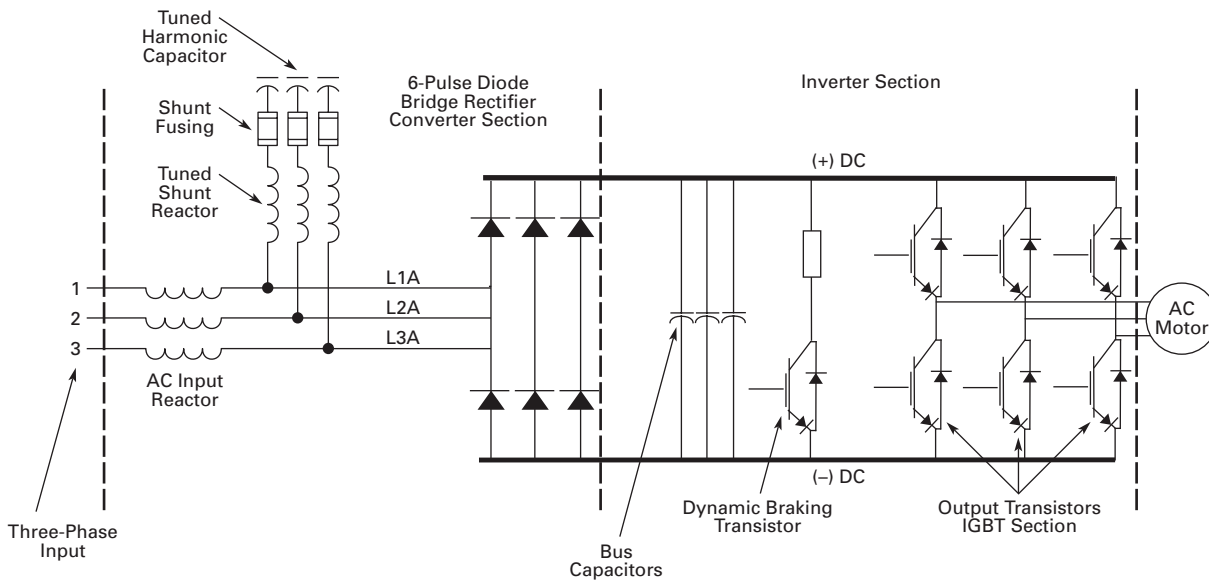

### 100 hp CFX9000 480V Drive with Integrated Passive Filter

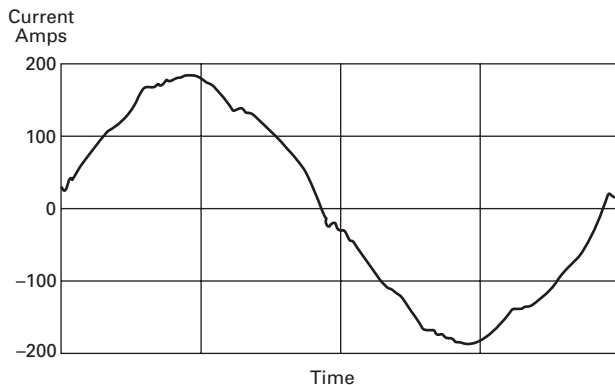

### 100 hp CFX9000 480V Drive with Integrated Passive Filter

#### Passive Filter

##### Current harmonics

$I_1 = 100\%$	$I_{11} = 0.24\%$	$I_{19} = 0.50\%$
$I_5 = 3.76\%$	$I_{13} = 1.1\%$	$I_{23} = 0.55\%$
$I_7 = 1.65\%$	$I_{17} = 0.80\%$	$I_{25} = 0.80\%$

Power = 100 hp

$H_c = 8.6$  Amps

#### Advantages

- Low cost for smaller horsepower applications
- More effective harmonic attenuation than 12-pulse drives
- Provides increased input protection for AFD from line transients

#### Disadvantages

- Capacitors age over time, unlike magnetics
- Not as effective as 18-pulse drives
- Challenging to retrofit with bypass applications

### 3. 12-Pulse Converters

A 12-pulse converter incorporates two separate AFD input semiconductor bridges, which are fed from 30° phase shifted power sources with identical impedance. The sources may be two isolation transformers, where one is a delta/wye design (which provides the phase shift) and

the second a delta/delta design (which does not phase shift). The 12-pulse arrangement allows the harmonics from the first converter to cancel the harmonics of the second. Up to approximately 85% reduction of harmonic current and voltage distortion may be achieved (over standard

six-pulse converter). This permits a facility to use a larger percentage of AFD loads under IEEE 519-1992 guidelines than allowable using line reactors or DC chokes. A harmonic analysis is required to guarantee compliance with guidelines.

#### Basic 12-Pulse Rectifier with "Phase Shifting" Transformer

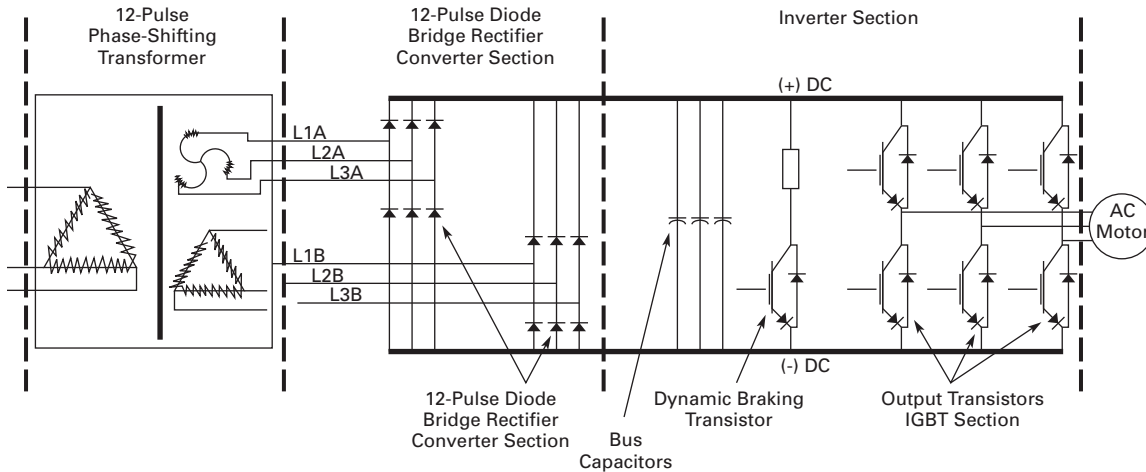

#### 100 hp 480V Drive with 12-Pulse Rectifier

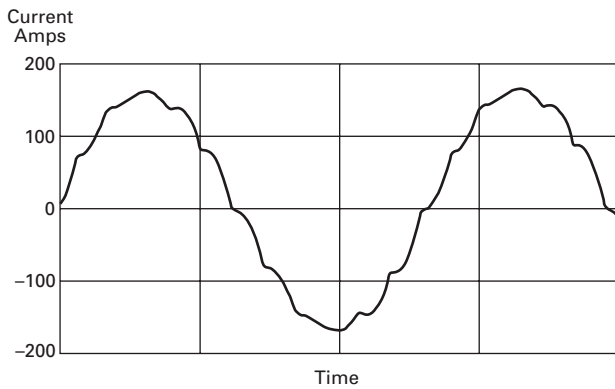

#### 100 hp 480V Drive with 12-Pulse Rectifier

##### 12-Pulse Circuit

Current harmonics

$I_1 = 100\%$	$I_{11} = 4.19\%$	$I_{19} = 0.06\%$
$I_5 = 1.25\%$	$I_{13} = 2.95\%$	$I_{23} = 0.87\%$
$I_7 = 0.48\%$	$I_{17} = 0.21\%$	$I_{25} = 0.73\%$

Power = 100 hp

$H_c = 20$  Amps

##### Advantages

- Reasonable cost, although significantly more than reactors or chokes
- Substantial reduction (up to approx. 85%) in voltage and current harmonics
- Provides increased input protection for AFD and its semiconductors from line transients

##### Disadvantages

- Impedance matching of phase shifted sources is critical to performance
- Transformers often require separate mounting or larger AFD enclosures
- May not reduce distribution harmonic levels to below IEEE 519-1992 guidelines
- Cannot retrofit for most AFDs

#### 4. Clean Power Drives

When the total load is comprised of non-linear load such as drives, and the ratio is  $I_{SC}/I_L$ , the greatest harmonic mitigation is required. Under these conditions, the currents drawn from the supply need to be sinusoidal and "clean" such that system interference and additional

losses are negligible. Eaton's CPX9000 clean power drive uses a phase-shifting auto-transformer with delta-connected winding that carries only the ampere-turns caused by the difference in load currents. This results in nine separate phases. In this type of configuration, the

total kVA rating of the transformer magnetic system was only 48% that of the motor load. A traditional isolated transformer system, with multipulse windings, would require the full kVA rating to be supported, which is more common in an MV step-down transformer.

The integrated 18-pulse clean power drive, with near sine wave input current and low harmonics will meet the requirements of IEEE 519-1992 under all practical operating conditions. The comparisons with six-pulse passive filter and 12-pulse systems are shown on **Pages V6-T36-161, V6-T36-163** and below.

#### Basic 18-Pulse Rectifier with Phase-Shifting Auto-Transformer

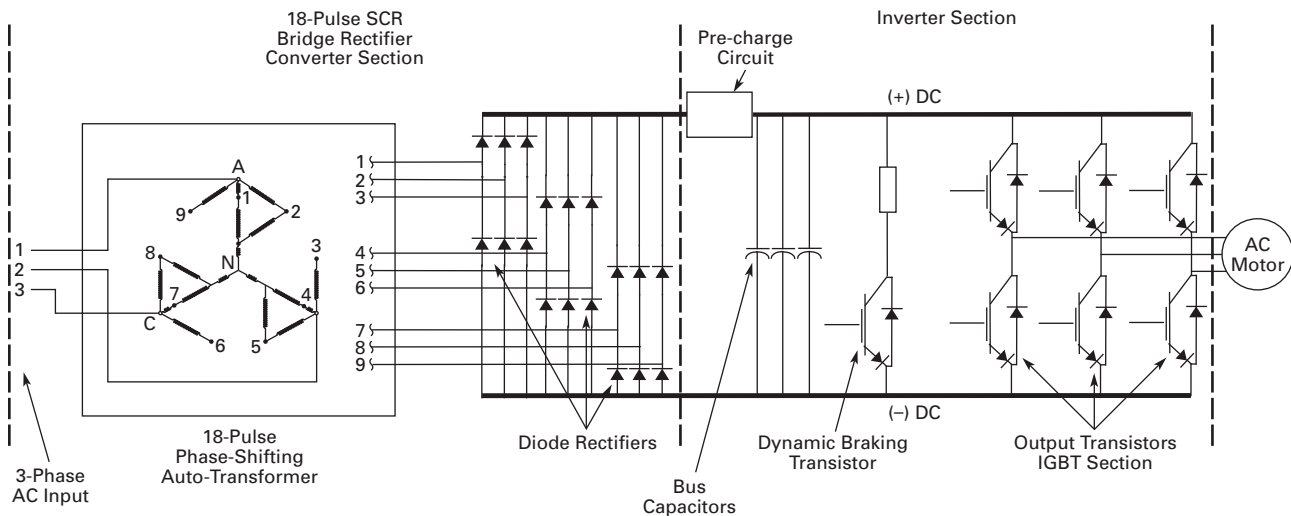

#### 100 hp 480V Drive with 18-Pulse Rectifiers

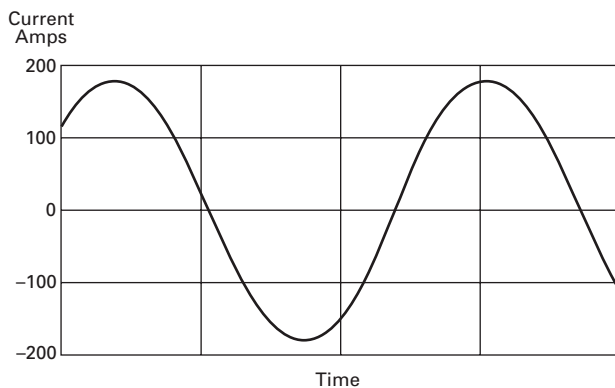

#### 100 hp 480V Drive with 18-Pulse Rectifiers

##### 18-Pulse Clean Power

##### Current harmonics

$I_1 = 100\%$	$I_{11} = 0.24\%$	$I_{19} = 1.00\%$
$I_5 = 0.16\%$	$I_{13} = 0.10\%$	$I_{23} = 0.01\%$
$I_7 = 0.03\%$	$I_{17} = 0.86\%$	$I_{25} = 0.01\%$

Power = 100 hp

$H_c = 5.9$  Amps

##### Advantages

- Effectively guarantees compliance with IEEE 519-1992
- Provides increased input protection for AFD and its semiconductors from line transients
- Up to 4 times the harmonic reduction of 12-pulse methods
- Smaller transformer than isolation transformer used in 12-pulse converter
- Minimizes ripple current in capacitors, doubling expected capacitor life

##### Disadvantages

- Not as cost effective as some other methods at small (<50) horsepower

# 36.6

## Adjustable Frequency Drives

### CFX9000 Drives

36

#### Features and Benefits

New CFX9000 Integrated Filter Clean Power Drive features include (at 480V):

- UL Type 1, UL Type 12, UL Type 3R and NEMA 12 with gaskets and filters
- Input voltage: 480V, 230V, 575V
- Complete range of control, network and power options

- Horsepower range:
  - 480V, 7-1/2–400 hp  $I_L$
  - 230V, 7-1/2–100 hp  $I_L$ ; consult factory for details
  - 575V, 15–400 hp  $I_L$ ; consult factory for details

- Single enclosure for both drive and filter reduces field wiring and enables convenient bypass installation
- Packaged solution ensures optimal coordination of drive and filter

#### Standards and Certifications

- UL
- cUL
- 508C



#### Product Identification

##### CFX9000 Drive—UL Type 12, 40 hp

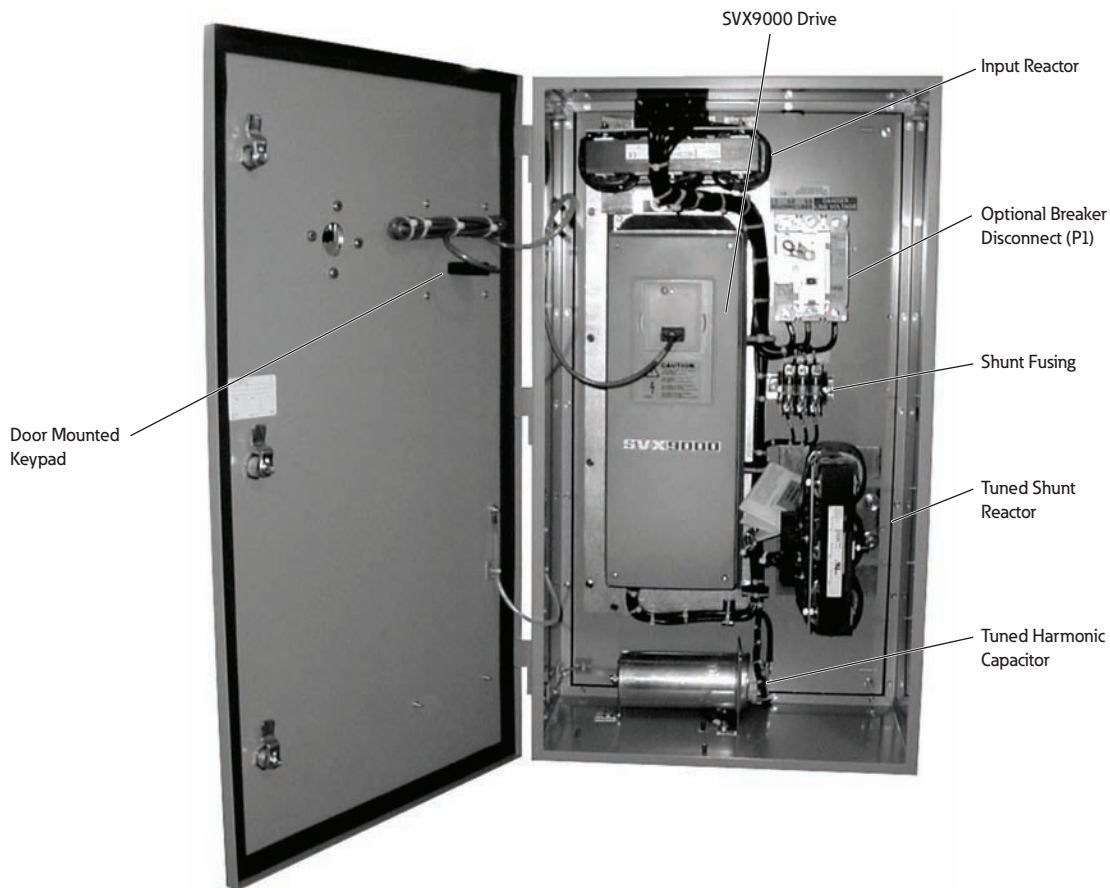

## Catalog Number Selection

## CFX9000 Enclosed Drives

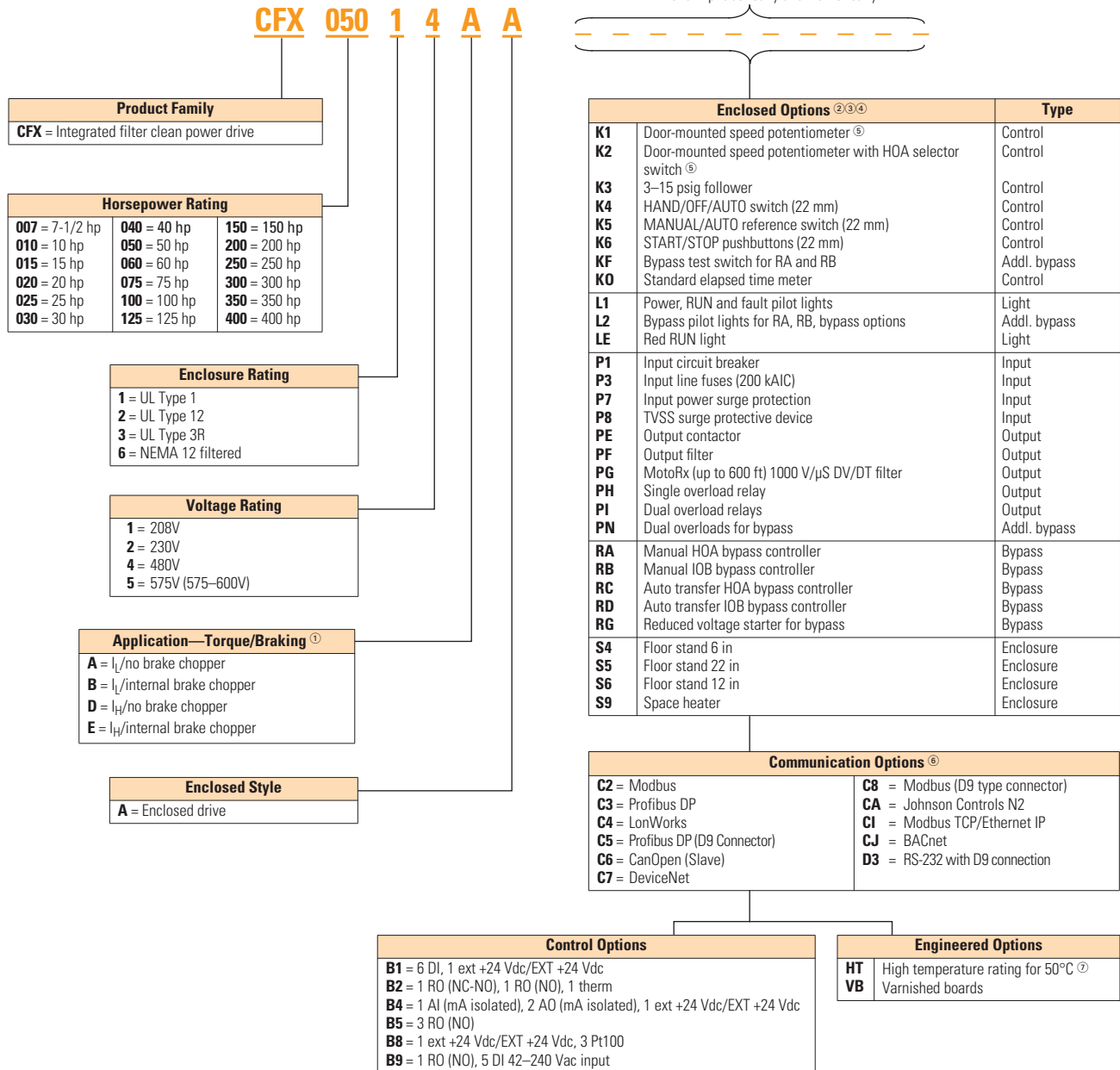

## Notes

- ① Brake chopper is standard in 208V, 230V and 480V drives up to FR6; optional in all other drives.
- ② Local/remote keypad is included as the standard control panel.
- ③ Some options are voltage and/or horsepower specific. Consult your Eaton representative for details.
- ④ See **Pages V6-T36-177** and **V6-T36-178** for complete descriptions.
- ⑤ Includes local/remote speed reference switch.
- ⑥ See **Pages V6-T36-175** and **V6-T36-176** for complete descriptions.
- ⑦ Consult Eaton for availability.

## Product Selection

36

### When Ordering

- Select a base catalog number that meets the application requirements—nominal horsepower, voltage and enclosure rating. (The enclosed drive's continuous output amp rating should be equal to or greater than the motor's full load amp rating.) The base enclosed package includes a standard drive, door-mounted alphanumeric panel and enclosure.
- The CFX9000 product uses the term High Overload ( $I_H$ ) in place of the term Constant Torque (CT). Likewise, Low Overload ( $I_L$ ) is used in place of the term Variable Torque (VT). The new terms are a more precise description of the rating. The older terms included ambient temperature ratings in addition to overload ratings. In order to minimize enclosure size and offer the highest ambient temperature rating, overload and temperature ratings are now treated separately. Ambient temperature ratings are shown in the following table.

### Ambient Temperature Ratings

Enclosure Size	$I_H$	$I_L$
B, C, 9 <sup>①</sup>	40°C	40°C
7, 8	50°C	50°C

- If dynamic brake chopper or control/communication option is desired, change the appropriate code in the base catalog number.
- All of the programming is exactly the same as the standard SVX9000 drive.
- Select enclosed options. Add the codes as suffixes to the base catalog number in alphabetical and numeric order.

#### Note

- <sup>①</sup> For high temperature rating, select HT option code and contact factory.



## 208V Drives

## CFX9000 Drive



## UL Type 1, UL Type 12, UL Type 3R and NEMA 12 Filtered

hp	NEC Current (A)	Chassis Frame	UL Type 1 Base Catalog Number	UL Type 12 and NEMA 12 Filtered Base Catalog Number	UL Type 3R Base Catalog Number
<b>Low Overload Drive</b>					
7-1/2	24.2	FR5	①	CFX00721BA	CFX00731BA
10	30.8	FR5	①	CFX01021BA	CFX01031BA
15	46.2	FR6	①	CFX01521BA	CFX01531BA
20	59.4	FR6	①	CFX02021BA	CFX02031BA
25	74.8	FR7	①	CFX02521AA	CFX02531AA
30	88	FR7	①	CFX03021AA	CFX03031AA
40	114	FR7	①	CFX04021AA	CFX04031AA
50	143	FR8	CFX05011AA	CFX05061AA	CFX05031AA
60	169	FR8	CFX06011AA	CFX06061AA	CFX06031AA
75	211	FR8	CFX07511AA	CFX07561AA	CFX07531AA
100	273	FR9	CFX10011AA	CFX10061AA	CFX10031AA
<b>High Overload Drive</b>					
7-1/2	24.2	FR5	①	CFX00721EA	CFX00731EA
10	30.8	FR6	①	CFX01021EA	CFX01031EA
15	46.2	FR6	①	CFX01521EA	CFX01531EA
20	59.4	FR7	①	CFX02021DA	CFX02031DA
25	74.8	FR7	①	CFX02521DA	CFX02531DA
30	88	FR7	①	CFX03021DA	CFX03031DA
40	114	FR8	CFX04011DA	CFX04061DA	CFX04031DA
50	143	FR8	CFX05011DA	CFX05061DA	CFX05031DA
60	169	FR8	CFX06011DA	CFX06061DA	CFX06031DA
75	211	FR9	CFX07511DA	CFX07561DA	CFX07531DA
100	273	FR9	CFX10011DA	CFX10061DA	CFX10031DA

## CFX9000 Enclosure

Chassis Frame	UL Type 1		UL Type 12		UL Type 3R	
	Disconnect Only	With Power Options	Disconnect Only	With Power Options	Disconnect Only	With Power Options
FR4	N/A	N/A	B	C	B	C
FR5	N/A	N/A	B	C	B	C
FR6	N/A	N/A	B	C	B	C
FR7	N/A	7	C	7	C	D
FR8	7	7	7	7	F	F
FR9	8	8	8	8	F	F

## Enclosure Dimension Drawings

Enclosure Size	UL Type 1 and UL Type 12	UL Type 3R
B	See Page V6-T36-183	See Page V6-T36-185
C	See Page V6-T36-184	See Page V6-T36-186
D	N/A	See Page V6-T36-187
F	N/A	See Page V6-T36-188
7 <sup>②</sup>	See Page V6-T36-189	③
8 <sup>②</sup>	See Page V6-T36-190	③
9	See Page V6-T36-191	③

## Notes

- ① FR5–FR7 drives not available in UL Type 1.
- ② Enclosures 7 and 8 are NEMA 12 filtered.
- ③ Not available for UL Type 3R.

#### 230V Drives

36

#### CFX9000 Drive



#### UL Type 1, UL Type 12, UL Type 3R and NEMA 12 Filtered

hp	NEC Current (A)	Chassis Frame	UL Type 1 Base Catalog Number	UL Type 12 and NEMA 12 Filtered Base Catalog Number	UL Type 3R Base Catalog Number
<b>Low Overload Drive</b>					
7-1/2	22	FR5	①	CFX00722BA	CFX00732BA
10	28	FR5	①	CFX01022BA	CFX01032BA
15	42	FR6	①	CFX01522BA	CFX01532BA
20	54	FR6	①	CFX02022BA	CFX02032BA
25	68	FR7	①	CFX02522AA	CFX02532AA
30	80	FR7	①	CFX03022AA	CFX03032AA
40	104	FR7	①	CFX04022AA	CFX04032AA
50	130	FR8	CFX05012AA	CFX05062AA	CFX05032AA
60	154	FR8	CFX06012AA	CFX06062AA	CFX06032AA
75	192	FR8	CFX07512AA	CFX07562AA	CFX07532AA
100	248	FR9	CFX10012AA	CFX10062AA	CFX10032AA
<b>High Overload Drive</b>					
7-1/2	22	FR5	①	CFX00722EA	CFX00732EA
10	28	FR6	①	CFX01022EA	CFX01032EA
15	42	FR6	①	CFX01522EA	CFX01532EA
20	54	FR7	①	CFX02022DA	CFX02032DA
25	68	FR7	①	CFX02522DA	CFX02532DA
30	80	FR7	①	CFX03022DA	CFX03032DA
40	104	FR8	CFX04012DA	CFX04062DA	CFX04032DA
50	130	FR8	CFX05012DA	CFX05062DA	CFX05032DA
60	154	FR8	CFX06012DA	CFX06062DA	CFX06032DA
75	192	FR9	CFX07512DA	CFX07562DA	CFX07532DA
100	248	FR9	CFX10012DA	CFX10062DA	CFX10032DA

#### CFX9000 Enclosure

Chassis Frame	UL Type 1		UL Type 12		UL Type 3R	
	Disconnect Only	With Power Options	Disconnect Only	With Power Options	Disconnect Only	With Power Options
FR4	N/A	N/A	B	C	B	C
FR5	N/A	N/A	B	C	B	C
FR6	N/A	N/A	B	C	B	C
FR7	N/A	7	C	7	C	D
FR8	7	7	7	7	F	F
FR9	8	8	8	8	F	F

#### Enclosure Dimension Drawings

Enclosure Size	UL Type 1 and UL Type 12	UL Type 3R
B	See Page V6-T36-183	See Page V6-T36-185
C	See Page V6-T36-184	See Page V6-T36-186
D	N/A	See Page V6-T36-187
F	N/A	See Page V6-T36-188
7 <sup>②</sup>	See Page V6-T36-189	③
8 <sup>②</sup>	See Page V6-T36-190	③
9	See Page V6-T36-191	③

#### Notes

- ① FR5–FR7 drives not available in UL Type 1.
- ② Enclosures 7 and 8 are NEMA 12 filtered.
- ③ Not available for UL Type 3R.

## 480V Drives

## CFX9000 Drive



## CFX9000 Base Drive

hp	NEC Current (A)	Chassis Frame	UL Type 1 Base Catalog Number <sup>①</sup>	UL Type 12 and NEMA 12 Filtered Base Catalog Number <sup>①</sup>	UL Type 3R Base Catalog Number <sup>①</sup>
<b>Low Overload Drive</b>					
7-1/2	11	FR4	②	CFX00724BA	CFX00734BA
10	14	FR5	②	CFX01024BA	CFX01034BA
15	21	FR5	②	CFX01524BA	CFX01534BA
20	27	FR5	②	CFX02024BA	CFX02034BA
25	34	FR6	②	CFX02524BA	CFX02534BA
30	40	FR6	②	CFX03024BA	CFX03034BA
40	52	FR6	②	CFX04024BA	CFX04034BA
50	65	FR7	CFX05014AA <sup>③</sup>	CFX05024AA	CFX05034AA
60	77	FR7	CFX06014AA <sup>③</sup>	CFX06024AA	CFX06034AA
75	96	FR7	CFX07514AA <sup>③</sup>	CFX07524AA	CFX07534AA
100	124	FR8	CFX10014AA	CFX10064AA	CFX10034AA
125	156	FR8	CFX12514AA	CFX12564AA	CFX12534AA
150	180	FR8	CFX15014AA	CFX15064AA	CFX15034AA
200	240	FR9	CFX20014AA	CFX20064AA	CFX20034AA
250	302	FR9	CFX25014AA	CFX25064AA	CFX25034AA
300	361	FR10	CFX30014AA	CFX30064AA	④
350	414	FR10	CFX35014AA	CFX35064AA	④
400	477	FR10	CFX40014AA	CFX40064AA	④
<b>High Overload Drive</b>					
7-1/2	11	FR5	②	CFX00724EA	CFX00734EA
10	14	FR5	②	CFX01024EA	CFX01034EA
15	21	FR5	②	CFX01524EA	CFX01534EA
20	27	FR6	②	CFX02024EA	CFX02034EA
25	34	FR6	②	CFX02524EA	CFX02534EA
30	40	FR6	②	CFX03024EA	CFX03034EA
40	52	FR7	CFX04014DA <sup>③</sup>	CFX04024DA	CFX04034DA
50	65	FR7	CFX05014DA <sup>③</sup>	CFX05024DA	CFX05034DA
60	77	FR7	CFX06014DA <sup>③</sup>	CFX06024DA	CFX06034DA
75	96	FR8	CFX07514DA	CFX07564DA	CFX07534DA
100	124	FR8	CFX10014DA	CFX10064DA	CFX10034DA
125	156	FR8	CFX12514DA	CFX12564DA	CFX12534DA
150	180	FR9	CFX15014DA	CFX15064DA	CFX15034DA
200	240	FR9	CFX20014DA	CFX20064DA	CFX20034DA
250	302	FR10	CFX25014DA	CFX25064DA	④
300	361	FR10	CFX30014DA	CFX30064DA	④
350	414	FR10	CFX35014DA	CFX35064DA	④

**Notes**

- ① The integrated filter clean power assembly includes a standard drive, door-mounted local/remote keypad and enclosure.  
 ② FR4–FR6 drives not available in UL Type 1.  
 ③ This catalog number is used only with power options.  
 ④ Consult factory.

**CFX9000 Enclosure**

Chassis Frame	UL Type 1		UL Type 12		UL Type 3R	
	Disconnect Only	With Power Options	Disconnect Only	With Power Options	Disconnect Only	With Power Options
FR4	N/A	N/A	B	C	B	C
FR5	N/A	N/A	B	C	B	C
FR6	N/A	N/A	B	C	B	C
FR7	N/A	7	C	7	C	D
FR8	7	7	7	7	F	F
FR9	8	8	8	8	F	F
FR10	9	9	9	9	①	①

**Enclosure Dimension Drawings**

Enclosure Size	UL Type 1 and UL Type 12	UL Type 3R
<b>B</b>	See <a href="#">Page V6-T36-183</a>	See <a href="#">Page V6-T36-185</a>
<b>C</b>	See <a href="#">Page V6-T36-184</a>	See <a href="#">Page V6-T36-186</a>
<b>D</b>	N/A	See <a href="#">Page V6-T36-187</a>
<b>F</b>	N/A	See <a href="#">Page V6-T36-188</a>
<b>7</b> ②	See <a href="#">Page V6-T36-189</a>	③
<b>8</b> ②	See <a href="#">Page V6-T36-190</a>	③
<b>9</b>	See <a href="#">Page V6-T36-191</a>	③

**Notes**

- ① Consult factory.
- ② Enclosures 7 and 8 are NEMA 12 filtered.
- ③ Not available for UL Type 3R.

## 575V Drives

## CFX9000 Drive



## UL Type 1, UL Type 12, UL Type 3R and NEMA 12 Filtered

hp	NEC Current (A)	Chassis Frame	UL Type 1 Base Catalog Number	UL Type 12 and NEMA 12 Filtered Base Catalog Number	UL Type 3R Base Catalog Number
<b>Low Overload Drive</b>					
15	17	FR6	①	CFX01525AA	CFX01535AA
20	22	FR6	①	CFX02025AA	CFX02035AA
25	27	FR6	①	CFX02525AA	CFX02535AA
30	32	FR6	①	CFX03025AA	CFX03035AA
40	41	FR7	①	CFX04025AA	CFX04035AA
50	52	FR7	①	CFX05025AA	CFX05035AA
60	62	FR8	CFX06015AA	CFX06065AA	CFX06035AA
75	77	FR8	CFX07515AA	CFX07565AA	CFX07535AA
100	99	FR8	CFX10015AA	CFX10065AA	CFX10035AA
125	125	FR9	CFX12515AA	CFX12565AA	CFX12535AA
150	144	FR9	CFX15015AA	CFX15065AA	CFX15035AA
200	192	FR9	CFX20015AA	CFX20065AA	CFX20035AA
250	242	FR10	CFX25015AA	CFX25065AA	②
300	289	FR10	CFX30015AA	CFX30065AA	②
400	382	FR10	CFX40015AA	CFX40065AA	②
<b>High Overload Drive</b>					
10	14	FR6	①	CFX01025DA	CFX01035DA
15	17	FR6	①	CFX01525DA	CFX01535DA
20	22	FR6	①	CFX02025DA	CFX02035DA
25	27	FR6	①	CFX02525DA	CFX02535DA
30	32	FR7	①	CFX03025DA	CFX03035DA
40	41	FR7	①	CFX04025DA	CFX04035DA
50	52	FR8	CFX05015DA	CFX05065DA	CFX05035DA
60	62	FR8	CFX06015DA	CFX06065DA	CFX06035DA
75	77	FR8	CFX07515DA	CFX07565DA	CFX07535DA
100	99	FR9	CFX10015DA	CFX10065DA	CFX10035DA
125	125	FR9	CFX12515DA	CFX12565DA	CFX12535DA
150	144	FR9	CFX15015DA	CFX15065DA	CFX15035DA
200	192	FR10	CFX20015DA	CFX20065DA	②
250	242	FR10	CFX25015DA	CFX25065DA	②
300	289	FR10	CFX30015DA	CFX30065DA	②

**Notes**

- ① FR6–FR7 drives not available in UL Type 1.  
 ② Consult factory.

**CFX9000 Enclosure**

Chassis Frame	UL Type 1		UL Type 12		UL Type 3R	
	Disconnect Only	With Power Options	Disconnect Only	With Power Options	Disconnect Only	With Power Options
FR6	N/A	N/A	B	C	B	C
FR7	N/A	7	C	7	C	D
FR8	7	7	7	7	F	F
FR9	8	8	8	8	F	F
FR10	9	9	9	9	①	①

**Enclosure Dimension Drawings**

Enclosure Size	UL Type 1 and UL Type 12	UL Type 3R
<b>B</b>	See <a href="#">Page V6-T36-183</a>	See <a href="#">Page V6-T36-185</a>
<b>C</b>	See <a href="#">Page V6-T36-184</a>	See <a href="#">Page V6-T36-186</a>
<b>D</b>	N/A	See <a href="#">Page V6-T36-187</a>
<b>F</b>	N/A	See <a href="#">Page V6-T36-188</a>
<b>7</b> ②	See <a href="#">Page V6-T36-189</a>	③
<b>8</b> ②	See <a href="#">Page V6-T36-190</a>	③
<b>9</b>	See <a href="#">Page V6-T36-191</a>	③

**Notes**

- ① Consult factory.
- ② Enclosures 7 and 8 are NEMA 12 filtered.
- ③ Not available for UL Type 3R.

## Options

### CFX9000 Series Option Board Kits

The CFX9000 Series drives can accommodate a wide selection of expander and adapter option boards to customize the drive for your application needs. The drive's control unit is designed to accept a total of five option boards.

The CFX9000 Series factory-installed standard board configuration includes an A9 I/O board and an A2 relay output board, which are installed in slots A and B.

#### Option Boards

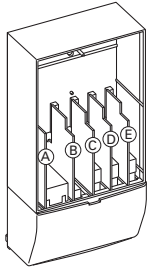

#### Option Board Kits

Option Kit Description <sup>①</sup>	Allowed Slot Locations <sup>②</sup>	Field Installed Catalog Number	Factory Installed Option Designator	SVX Ready Programs						
				Basic	Local/Remote	Standard	MSS	PID	Multi-P.	PFC
<b>Standard I/O Cards</b>										
2 RO (NC/NO)	B	<b>OPTA2</b>	—	■	■	■	■	■	■	■
6 DI, 1 DO, 2 AI, 1AO, 1 +10 Vdc ref, 2 ext +24 Vdc/ext +24 Vdc	A	<b>OPTA9</b>	—	■	■	■	■	■	■	■
<b>Extended I/O Cards</b>										
6 DI	B, C, <b>D</b> , E	<b>OPTB1</b>	<b>B1</b>	—	—	—	—	—	■	■
1 RO (NC/NO), 1 RO (NO), 1 therm	B, C, <b>D</b> , E	<b>OPTB2</b>	<b>B2</b>	—	—	—	—	—	■	■
1 AI (mA isolated), 2 AO (mA isolated)	B, C, <b>D</b> , E	<b>OPTB4</b>	<b>B4</b>	■	■	■	■	■	■	■
3 RO (NO)	B, C, <b>D</b> , E	<b>OPTB5</b>	<b>B5</b>	—	—	—	—	—	■	■
3 Pt100 RTD board	B, C, <b>D</b> , E	<b>OPTB8</b>	<b>B8</b>	—	—	—	—	—	■	—
1 RO (NO), 5 DI 42–240 Vac input	B, C, <b>D</b> , E	<b>OPTB9</b>	<b>B9</b>	—	—	—	—	—	■	■
<b>Communication Cards <sup>③</sup></b>										
Modbus	D, <b>E</b>	<b>OPTC2</b>	<b>C2</b>	■	■	■	■	■	■	■
Modbus TCP	D, <b>E</b>	<b>OPTCI</b>	<b>CI</b>	■	■	■	■	■	■	■
BACnet	D, <b>E</b>	<b>OPTCJ</b>	<b>CJ</b>	■	■	■	■	■	■	■
Ethernet IP	D, <b>E</b>	<b>OPTCK</b>	<b>CK</b>	■	■	■	■	■	■	■
Johnson Controls N2	D, <b>E</b>	<b>OPTC2</b>	<b>CA</b>	■	■	■	■	■	■	■
PROFIBUS DP	D, <b>E</b>	<b>OPTC3</b>	<b>C3</b>	■	■	■	■	■	■	■
LonWorks	D, <b>E</b>	<b>OPTC4</b>	<b>C4</b>	■	■	■	■	■	■	■
PROFIBUS DP (D9 connector)	D, <b>E</b>	<b>OPTC5</b>	<b>C5</b>	■	■	■	■	■	■	■
CANopen (slave)	D, <b>E</b>	<b>OPTC6</b>	<b>C6</b>	■	■	■	■	■	■	■
DeviceNet	D, <b>E</b>	<b>OPTC7</b>	<b>C7</b>	■	■	■	■	■	■	■
Modbus (D9 type connector)	D, <b>E</b>	<b>OPTC8</b>	<b>C8</b>	■	■	■	■	■	■	■
RS-232 with D9 connection	D, <b>E</b>	<b>OPTD3</b>	<b>D3</b>	■	■	■	■	■	■	■

#### Notes

① AI = Analog Input; AO = Analog Output, DI = Digital Input, DO = Digital Output, RO = Relay Output

② Option card must be installed in one of the slots listed for that card. Slot indicated in bold is the preferred location.

③ OPTC2 is a multi-protocol option card.

**Modbus RTU Network Communications**

The Modbus Network Card OPTC2 is used for connecting the 9000X Drive as a slave on a Modbus network. The interface is connected by a 9-pin DSUB connector (female) and the baud rate ranges from 300 to 19,200 baud. Other communication parameters include an address range from 1 to 247; a parity of None, Odd or Even; and the stop bit is 1.

**PROFIBUS Network Communications**

The PROFIBUS Network Card OPTC3 is used for connecting the 9000X Drive as a slave on a PROFIBUS-DP network. The interface is connected by a 9-pin DSUB connector (female). The baud rates range from 9.6K baud to 12M baud, and the addresses range from 1 to 127.

**LonWorks Network Communications**

The LonWorks Network Card OPTC4 is used for connecting the 9000X Drive on a LonWorks network. This interface uses Standard Network Variable Types (SNVT) as data types. The channel connection is achieved using a FTT-10A Free Topology transceiver via a single twisted transfer cable. The communication speed with LonWorks is 78 kBits/s.

**CANopen (Slave) Communications**

The CANopen (Slave) Network Card OPTC6 is used for connecting the 9000X Drive to a host system. According to ISO® 11898 standard cables to be chosen for CAN bus should have a nominal impedance of 120 ohms, and specific line delay of nominal 5 as/m. 120 ohm line termination resistors required for installation.

**DeviceNet Network Communications**

The DeviceNet Network Card OPTC7 is used for connecting the 9000X Drive on a DeviceNet Network. It includes a 5.08 mm pluggable connector. Transfer method is via CAN using a two-wire twisted shielded cable with two-wire bus power cable and drain. The baud rates used for communication include 125K baud, 250K baud and 500K baud.

**Johnson Controls Metasys N2 Network Communications**

The OPTC2 fieldbus board provides communication between the 9000X Drive and a Johnson Controls Metasys™ N2 network. With this connection, the drive can be controlled, monitored and programmed from the Metasys system. The N2 fieldbus is available as a factory-installed option and as a field-installable kit.

**Modbus/TCP Network Communications**

The Modbus/TCP Network Card OPTC1 is used for connecting the 9000X Drive to Ethernet networks using Modbus protocol. It includes an RJ-45 pluggable connector. This interface provides a selection of standard and custom register values to communicate drive parameters. The board supports 10 Mbps and 100 Mbps communication speeds. The IP address of the board is configurable over Ethernet using a supplied software tool.

**BACnet Network Communications**

The BACnet Network Card OPTCJ is used for connecting the 9000X Drive to BACnet networks. It includes a 5.08 mm pluggable connector. Data transfer is Master-Slave/Token Passing (MS/TP) RS-485. This interface uses a collection of 30 Binary Value Objects (BVOs) and 35 Analog Value Objects (AVOs) to communicate drive parameters. The card supports 9.6, 19.2 and 38.4 Kbaud communication speeds and supports network addresses 1 to 127.

**Ethernet/IP Network Communications**

The Ethernet/IP Network Card OPTCK is used for connecting the 9000X Drive to Ethernet/Industrial Protocol networks. It includes an RJ-45 pluggable connector. The interface uses CIP objects to communicate drive parameters (CIP is "Common Industrial Protocol," the same protocol used by DeviceNet). The board supports 10 Mbps and 100 Mbps communication speeds. The IP address of the board is configurable by Static, BOOTP and DHCP methods.



## Control/Communication Option Descriptions

## Available Control/Communications Options

Option	Description	Option Type
K1	<b>Door-Mounted Speed Potentiometer</b> —Provides the drive with the ability to adjust the frequency reference using a door-mounted potentiometer. This option uses the 10 Vdc reference to generate a 0–10V signal at the analog voltage input signal terminal. When the HOA bypass option is added, the speed is controlled when the HOA switch is in the HAND position. Without the HOA bypass option, a two-position switch (labeled local/remote) is provided on the keypad to select speed reference from the speed potentiometer or a remote speed signal.	Control
K2	<b>Door-Mounted Speed Potentiometer with HOA Selector Switch</b> —Provides the drive with the ability to start/stop and adjust the speed reference from door-mounted control devices or remotely from customer supplied inputs. In HAND position, the drive will start and the speed is controlled by the door-mounted speed potentiometer. The drive will be disabled in the OFF position. When AUTO is selected, the drive run and speed control commands are via user-supplied dry contact and 4–20 mA signal.	Control
K3	<b>3–15 psig Follower</b> —Provides a pneumatic transducer which converts a 3–15 psig pneumatic signal to either 0–8 Vdc or a 1–9 Vdc signal interface with the drive. The circuit board is mounted on the inside of the front enclosure panel and connects to the user's pneumatic control system via 6 ft (1.8m) of flexible tubing and a 1/4 in (6.4 mm) brass tube union.	Control
K4	<b>HAND/OFF/AUTO Switch for Non-Bypass Configurations</b> —Provides a three-position selector switch that allows the user to select either a HAND or AUTO mode of operation. HAND mode is defaulted to keypad operation, and AUTO mode is defaulted to control from an external terminal source. These modes of operation can be configured via drive programming to allow for alternate combinations of start and speed sources. Start and speed sources include keypad, I/O and fieldbus.	Control
K5	<b>MANUAL/AUTO Speed Reference Switch</b> —Provides door-mounted selector switch for MANUAL/AUTO speed reference.	Control
K6	<b>START/STOP Pushbuttons</b> —Provide door-mounted START and STOP pushbuttons for either bypass or non-bypass configurations.	Control
KF	<b>Bypass Test Switch for RB and RA</b> —Allows the user to energize the AF drive for testing while operating the motor on the bypass controller. The Test Switch is mounted on the inside of the enclosure door.	Addl. bypass
KO	<b>Standard Elapsed Time Meter</b> —Provides a door-mounted elapsed run time meter.	Control
L1	<b>Power On, Run and Fault Lights</b> —Provide a white power on light that indicates power to the enclosed cabinets, a green run light and a red fault light that indicates a drive fault has occurred.	Light
L2	<b>Bypass Pilot Lights for RB, RA Bypass Options</b> —A green light indicates when the motor is running in inverter mode and an amber light indicates when the motor is running in bypass mode. The lights are mounted on the enclosure door, above the switches.	Addl. bypass
LE	<b>Red Run Pilot Light (22 mm)</b> —Provides a red run pilot light that indicates the drive is running.	Light
P1	<b>Input Circuit Breaker</b> —High interrupting circuit breaker that provides a means of short-circuit protection for the power cables between it and the CPX9000, and protection from high-level ground faults on the power cable. Allows a convenient means of disconnecting the CPX9000 from the line and the operating mechanism can be padlocked in the OFF position. This is factory mounted in the enclosure. Standard rating is 65 kAIC at 208/480V. 100 kAIC is available as an option.	Input
P3	<b>Input Line Fuses Rated to 200 kAIC</b> —Provide high-level fault protection of the drive input power circuit from the load side of the fuses to the input side of the power transistors. This option consists of three 200 kA fuses, which are factory mounted in the enclosure.	Input
P7	<b>MOV Surge Suppressor</b> —Provides a Metal Oxide Varistor (MOV) connected to the line side terminals and is designed to clip line side transients.	Input
P8	<b>TVSS Surge Protective Device with 50 kA Rating</b> —Provides transient voltage protection eliminating surges and spikes which can damage the diode bridge of the drive.	Input
PC	<b>Capacitor Contactor</b> —This option provides a contactor between the tuned reactor and capacitor to disconnect the capacitor from the circuit when desired, typically at light or no load conditions. This contactor is wired to a programmable relay output.	Input
PE	<b>Output Contactor</b> —Provides a means for positive disconnection of the drive output from the motor terminals. The contactor coil is controlled by the drive's run or permissive logic. NO auxiliary contacts rated at 10A, 600 Vac are provided for customer use. Bypass options <b>RB</b> and <b>RA</b> include an output contactor as standard. This option includes a low VA 115 Vac fused control power transformer and is factory mounted in the enclosure.	Output
PF	<b>Output Filter</b> —Used to reduce the transient voltage (DV/DT) at the motor terminals. The output filter is recommended for cable lengths exceeding 100 ft (30m) or for a drive rated at 525–690V. This option is mounted in the enclosure, and may be used in conjunction with a brake chopper circuit.	Output
PG	<b>MotoRx (300–600 ft) 1000 V/μS DV/DT Filter</b> —Used to reduce transient voltage (DV/DT) and peak voltages at the motor terminals. This option is comprised of a 0.5% line reactor, followed by capacitive filtering and an energy recovery/clamping circuit. Unlike the output filter (see option <b>PF</b> ), the MotoRx recovers most of the energy from the voltage peaks, resulting in a lower voltage drop to the motor, and therefore conserving power. This option is used when the distance between a single motor and the drive is 300–600 ft (91–183m). <i>This option cannot be used with the brake chopper circuit. The output filter (option <b>PF</b>) should be investigated as an alternative.</i>	Output
PH	<b>Single Overload Relay</b> —Uses a bimetallic overload relay to provide additional overload current protection to the motor on configurations without bypass options. It is included with the bypass configurations for overload current protection in the bypass mode. The overload relay is mounted within the enclosure, and is manually resettable. Heater pack included.	Output
PI	<b>Dual Overload Relays</b> —This option is recommended when a single drive is operating two motors and overload current protection is needed for each of the motors. The standard configuration includes two bimetallic overload relays, each sized to protect a motor with 50% of the drive hp rating. For example, a 100 hp drive would include two overload relays sized to protect two 50 hp motors. The relays are mounted within the enclosure, and are manually resettable. Heater packs not included.	Output
PN	<b>Dual Overloads for Bypass</b> —This option is recommended when a single drive is operating two motors in the bypass mode and overload current protection is needed for each of the motors. The standard configuration includes two bimetallic overload relays, each sized to protect a motor with 50% of the drive hp rating. For example, a 100 hp drive would include two overload relays sized to protect two 50 hp motors. The relays are mounted within the enclosure, and are manually resettable.	Addl. bypass

## Available Control/Communications Options, continued

Option	Description	Option Type
RA	<b>Manual HOA Bypass Controller</b> —The manual HAND/OFF/AUTO (HOA)—three-contactor—bypass option provides a means of bypassing the CFX9000, allowing the AC motor to be operated at full speed directly from the AC supply line. This option consists of an input HMCP, a fused control power transformer, and a full voltage bypass starter with a door-mounted HOA selector switch and an INVERTER/BYPASS switch. The HOA switch provides the ability to start and stop the drive in the inverter mode. IEC type input, bypass and input contactors are provided. The contactors are mechanically and electrically interlocked (see wiring diagram on <b>Page V6-T36-182</b> ).	Bypass
RB	<b>Manual IOB Bypass Controller</b> —The manual INVERTER/OFF/BYPASS (IOB)—three-contactor—bypass option provides a means of bypassing the CFX9000, allowing the AC motor to be operated at full speed directly from the AC supply line. This option consists of an input HMCP, a fused control power transformer, and a full voltage bypass starter with a door-mounted IOB selector switch. IEC type input, bypass and input contactors are provided. The contactors are mechanically and electrically interlocked (see wiring diagram on <b>Page V6-T36-182</b> ).	Bypass
RC	<b>Auto Transfer HOA Bypass Controller</b> —The manual HAND/OFF/AUTO (HOA)—three-contactor—bypass option provides a means of bypassing the CFX9000, allowing the AC motor to be operated at full speed directly from the AC supply line. The circuitry provides an automatic transfer of the load to “across the line” operation after a drive trip. This option consists of an input HMCP, a fused control power transformer, and a full voltage bypass starter with a door-mounted HOA selector switch and an INVERTER/BYPASS switch. The HOA switch provides the ability to start and stop the drive in either mode. IEC type input, bypass and input contactors are provided. The contactors are mechanically and electrically interlocked (see wiring diagram on <b>Page V6-T36-182</b> ). Door-mounted pilot lights are provided that indicate bypass or inverter operation. A green light indicates when the motor is running in inverter mode and an amber light indicates when the motor is running in bypass mode. <b>WARNING:</b> The motor may restart when the overcurrent relay is reset when operating in bypass, unless the IOB selector switch is turned to the OFF position.	Bypass
RD	<b>Auto Transfer IOB Bypass Controller</b> —The auto INVERTER/OFF/BYPASS (IOB)—three-contactor—bypass option provides a means of bypassing the CFX9000, allowing the AC motor to be operated at full speed directly from the AC supply line. The circuitry provides an automatic transfer of the load to “across the line” operation after a drive trip. This option consists of an input HMCP, a fused control power transformer, and a full voltage bypass starter with a door-mounted IOB selector switch. IEC type input, bypass and input contactors are provided. The contactors are mechanically and electrically interlocked (see wiring diagram on <b>Page V6-T36-182</b> ). Door-mounted pilot lights are provided that indicate bypass or inverter operation. A green light indicates when the motor is running in inverter mode and an amber light indicates when the motor is running in bypass mode. <b>WARNING:</b> The motor may restart when the overcurrent relay is reset when operating in bypass, unless the IOB selector switch is turned to the OFF position.	Bypass
RG	<b>Reduced Voltage Starter for Bypass</b> —Used in conjunction with bypass option RA, RB, RC or RD. This option adds <b>IT</b> Series reduced voltage soft starter to bypass assembly for soft starting in bypass mode.	Bypass
S4	<b>Floor Stand 6 in</b> —Raises “F” box off the ground 6 in (152.4 mm). Recommended when box is not installed on an appropriate concrete pad.	Enclosure
S5	<b>Floor Stand 22 in</b> —Converts a Size B or C, normally wall mounted enclosure to a floor standing enclosure with a height of 22 in (558.8 mm).	Enclosure
S6	<b>Floor Stand 12 in</b> —Converts a Size C or D, normally wall mounted enclosure to a floor standing enclosure with a height of 12 in (304.8 mm).	Enclosure
S9	<b>Space Heater</b> —Prevents condensation from forming in the enclosure when the drive is inactive or in storage. Includes a thermostat for variable temperature control. Heater requires a customer supplied 115V remote supply source.	Enclosure

## Enclosed Drive Options

Conformal (Varnished) Coating <sup>①</sup>

Chassis Frame	Delivery Code	Chassis Frame	Delivery Code
FR6	FP	FR9	FP
FR7	FP	FR10	FP
FR8	FP	FR11	FP
—	—	FR12	FP

## Light Options

Description	Catalog Number Suffix
Power on, run, fault LED lights (22 mm)	L1
Power on, fault LED lights (22 mm)	L3
Green LED run light (22 mm)	LA
Green LED stop light (22 mm)	LD
Red LED run light (22 mm)	LE
Red LED stop light (22 mm)	LF
Red LED fault light (22 mm)	LG
Power on white LED light (22 mm)	LJ
Miscellaneous LED light (22 mm)	LU

## Control Options

Description	Catalog Number Suffix
Door-mounted speed potentiometer	K1
Door-mounted speed potentiometer with HOA selector switch	K2
3–15 psig follower	K3
HOA selector switch	K4
MANUAL/AUTO reference switch	K5
START-STOP pushbuttons	K6
Type D2 control relay	SD
On-delay relay	SE
Off-delay relay	SF
Additional terminal blocks per 4 points	SD

**Note**

<sup>①</sup> See catalog number description to order.

**Bypass Control Options**

Description	Catalog Number Suffix
Bypass test switch used with RA and RB	KF
Inverter/bypass pilot lights	L2

**Meter Options**

Description	Catalog Number Suffix
Standard elapsed time meter	K0
Frequency meter	KS
MP-3000 relay with URTD	KV
MP-3000 relay with URTD and CTs	KU

**Enclosure Options**

Enclosure Size	Catalog Number Suffix
<b>Space Heater</b> <sup>①</sup>	
7	S9
8	S9
9	S9
B	S9
C	S9
D	S9
F	S9
<b>Plastic Nameplate</b>	
All	SN
<b>Floor Stand/Enclosure Size</b>	
6 in floor stand, size F	S4
22 in floor stand, size B and C	S5
12 in floor stand, size C and D	S6

**208V Power Options, 7-1/2–100 hp**

Description	Catalog Number Suffix
Input breaker	P1
Input line fusing	P2
Input line fuses 200 kAIC	P3
Output contactor	PE
Single overload relay	PH
Dual overload relays	PI
MOV	P7
50 kA surge protective device	P8
100 kA surge protective device	P9

**230V Power Options, 7-1/2–125 hp**

Description	Catalog Number Suffix
Input breaker	P1
Input line fusing	P2
Input line fuses 200 kAIC	P3
Output contactor	PE
Single overload relay	PH
Dual overload relays	PI
MOV	P7
50 kA surge protective device	P8
100 kA surge protective device	P9

**480 and 575V Power Options, 7-1/2–400 hp**

Description	Catalog Number Suffix
Input breaker	P1
Input line fusing	P2
Input line fuses 200 kAIC	P3
Output contactor	PE
Output filter	PF
MotoRx (300–600 ft) DV/DT filter	PG
Single overload relay	PH
Dual overload relays	PI
Input MOV	P7
50 kA surge protective device	P8
100 kA surge protective device	P9

**208V Bypass Options, 7-1/2–100 hp**

Description	Catalog Number Suffix
Manual HOA bypass controller	RA
IOB bypass controller	RB
Auto transfer HOA bypass controller	RC
Auto transfer IOB bypass controller	RD
Reduced voltage starter for bypass	RG
Dual overloads for bypass	PN

**230V Bypass Options, 7-1/2–125 hp**

Description	Catalog Number Suffix
Manual HOA bypass controller	RA
IOB bypass controller	RB
Auto transfer HOA bypass controller	RC
Auto transfer IOB bypass controller	RD
Reduced voltage starter for bypass	RG
Dual overloads for bypass	PN

**480 and 575V Bypass Options, 7-1/2–400 hp**

Description	Catalog Number Suffix
Manual HOA bypass controller	RA
IOB bypass controller	RB
Auto transfer HOA bypass controller	RC
Auto transfer IOB bypass controller	RD
Reduced voltage starter for bypass	RG
Dual overloads for bypass	PN

**Note**

<sup>①</sup> Requires customer-supplied 115 Vac supply.

## Technical Data and Specifications

### CFX9000 Drives

Description	Specification
<b>Primary Design Features</b>	
45–66 Hz input frequency	Standard
Output: AC volts maximum	Input Voltage Base
Output frequency range	0–320 Hz
Initial output current ( $I_H$ )	250% for 2 seconds
Overload (1 minute [ $I_H/I_L$ ])	150%/110%
Enclosure space heater	Optional
Oversize enclosure	Standard
Output contactor	Optional
Bypass motor starter	Optional
Listings	UL, cUL, 508C
<b>Protection Features</b>	
Incoming line fuses	Optional
AC input circuit disconnect	Optional
Phase rotation insensitive	Standard
EMI filter	Standard—FR6 thru FR9 <sup>①</sup>
Input phase loss protection	Standard
Input overvoltage protection	Standard
Line surge protection	Standard
Output short circuit protection	Standard
Output ground fault protection	Standard
Output phase protection	Standard
Overtemperature protection	Standard
DC overvoltage protection	Standard
Drive overload protection	Standard
Motor overload protection	Standard
Programmer software	Optional
Local/remote keypad	Standard
Keypad lockout	Standard
Fault alarm output	Standard
Built-in diagnostics	Standard
Surge protective device	Optional

Description	Specification
<b>Input/Output Interface Features</b>	
Setup adjustment provisions	
Remote keypad/display	Standard
Personal computer	Standard
Operator control provisions	
Drive mounted keypad/display	Standard
Remote keypad/display	Standard
Conventional control elements	Standard
Serial communications	Optional
115 Vac control circuit	Optional
Speed setting inputs	
Keypad	Standard
0–10 Vdc potentiometer/voltage signal	Standard
4–20 mA isolated	Configurable
4–20 mA differential	Configurable
3–15 psig	Optional
Analog outputs	
Speed/frequency	Standard
Torque/load/current	Programmable
Motor voltage	Programmable
Kilowatts	Programmable
0–10 Vdc signals	Configurable w/jumpers
4–20 mA DC signals	Standard
Isolated signals	Optional
Discrete outputs	
Fault alarm	Standard
Drive running	Standard
Drive at set speed	Programmable
Optional parameters	14
Dry contacts	2 relays Form C
Open collector outputs	1
Additional discrete outputs	Optional
<b>Communications</b>	
RS-232	Standard
RS-422/485	Optional
DeviceNet™	Optional
Modbus RTU	Optional
CanOpen (slave)	Optional
Profibus-DP	Optional
Lonworks®	Optional
Johnson Controls Metasys™ N2	Optional
Ethernet IP/Modbus TCP	Optional
BACnet	Optional

#### Note

<sup>①</sup> The EMI filter is optional in FR10.

## CFX9000 Drives, continued

Description	Specification
<b>Performance Features</b>	
Sensorless vector control	Standard
Volts/hertz control	Standard
IR and slip compensation	Standard
Electronic reversing	Standard
Dynamic braking	Optional
DC braking	Standard
PID setpoint controller	Programmable
Critical speed lockout	Standard
Current (torque) limit	Standard
Adjustable acceleration/deceleration	Standard
Linear or S curve accel/decel	Standard
Jog at preset speed	Standard
Thread/preset speeds	7
Automatic restart	Selectable
Coasting motor start	Standard
Coast or ramp stop selection	Standard
Elapsed time meter	Optional
<b>Standard Conditions for Application and Service</b>	
Maximum operating ambient temperature	0 to 40°C, contact factory for 50°C <sup>①</sup>
Storage temperature	-40 to 60°C
Humidity (maximum), non-condensing	95%
Altitude	100% load capacity (no derating) up to 3280 ft (1000m); 1% derating for each 328 ft (100m) above 3280 ft (1000m); max. 9842 ft (3000m)
Line voltage variation	+10/-15%
Line frequency variation	45-66 Hz
Efficiency	>96%
Power factor (displacement)	0.99

## Standard I/O Specifications

Description	Specification
Six-digital input programmable	24V: "0" ≤10V, "1" ≥18V, R <sub>i</sub> >5 kohms
Two-analog input configurable w/ jumpers	Voltage: 0-±10V, R <sub>i</sub> >200 kohms Current: 0 (4)-20 mA, R <sub>i</sub> = 250 kohms
Two-digital output programmable	Form C relays 250 Vac or 30 Vdc 2 Amp resistive
One-digital output programmable	Open collector 48 Vdc 50 mA
One-analog output programmable configurable w/jumper	0-20 mA, R <sub>L</sub> max. 500 ohms 10 bits ±2%

## I/O Specifications for Control/Communication Options

Description	Specification
Analog voltage, input	0-±10V, R <sub>i</sub> ≥200 kilohms
Analog current, input	0 (4)-20 mA, R <sub>i</sub> = 250 ohms
Digital input	24V: "0" ≤10V, "1" ≥18V, R <sub>i</sub> >5 kilohms
Auxiliary voltage	24V (±20%), max. 50 mA
Reference voltage	10V ±3%, max. 10 mA
Analog current, output	0 (4)-20 mA, R <sub>L</sub> = 500 kilohms, resolution 10 bit, accuracy ≤±2%
Analog voltage, output	0 (2)-10V, R <sub>L</sub> ≥1 kohm, resolution 10 bit, accuracy ≤±2%
Relay output max. switching voltage	300 Vdc, 250 Vac
Relay output max. switching load	3A/24 Vdc, 300 Vdc, 250 Vac <sup>②</sup>
Relay output max. continuous load	2A rms
Thermistor input	R <sub>trip</sub> = 4.7 kohms

**Notes**

① Units FR10 rated 40°C.

② For applications above 3A consult instruction manual.

#### Wiring Diagram

#### Control Input/Output

36

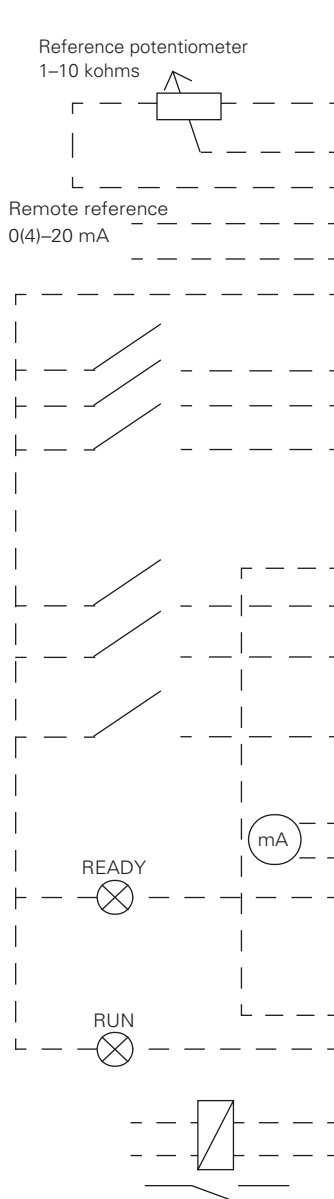

#### Basic Application Default I/O Configuration

Terminal	Signal	Description			
<b>OPTA9</b>					
1	+10V <sub>ref</sub>	Reference output Voltage for potentiometer, etc.			
2	AI1+	Analog input, voltage range 0-10 Vdc Voltage input frequency reference			
3	AI1-	I/O Ground Ground for reference and controls			
4	AI2+	Analog input, current range 0-20 mA Current input frequency reference			
5	AI2-				
6	+24V	Control voltage output Voltage for switches, etc. max 0.1A			
7	GND	I/O ground Ground for reference and controls			
8	DIN1	Start forward Contact closed = start forward			
9	DIN2	Start reverse Contact closed = start reverse			
10	DIN3	External fault input (programmable) Contact open = no fault Contact closed = fault			
11	CMA	Common for DIN 1-DIN 3 Connect to GND or +24V			
12	+24V	Control voltage output Voltage for switches (see terminal 6)			
13	GND	I/O ground Ground for reference and controls			
14	DIN4	Multi-step speed select 1	<b>DIN4</b>	<b>DIN5</b>	<b>Frequency Ref.</b>
15	DIN5	Multi-step speed select 2	Open	Open	Ref. V <sub>in</sub>
			Closed	Open	Multi-step ref. 1
			Open	Closed	Multi-step ref. 2
			Closed	Closed	Ref <sub>Max</sub>
16	DIN6	Fault reset Contact open = no action Contact closed = fault reset			
17	CMB	Common for DIN4-DIN6 Connect to GND or +24V			
18	A01+	Output frequency Programmable Range 0-20 mA, R <sub>L</sub> max. 500 ohms			
19	A01-	Analog output			
20	D01	Digital output READY Programmable Open collector, I ≤ 50 mA, V ≤ 48 Vdc			
<b>OPTA2</b>					
21	R01	Relay output 1 RUN			
22	R01				
23	R01				
24	R02	Relay output 2 FAULT			
25	R02				
26	R02				

## Dimensions

Approximate Dimensions in Inches (mm)

### Enclosure Size B—UL Type 12

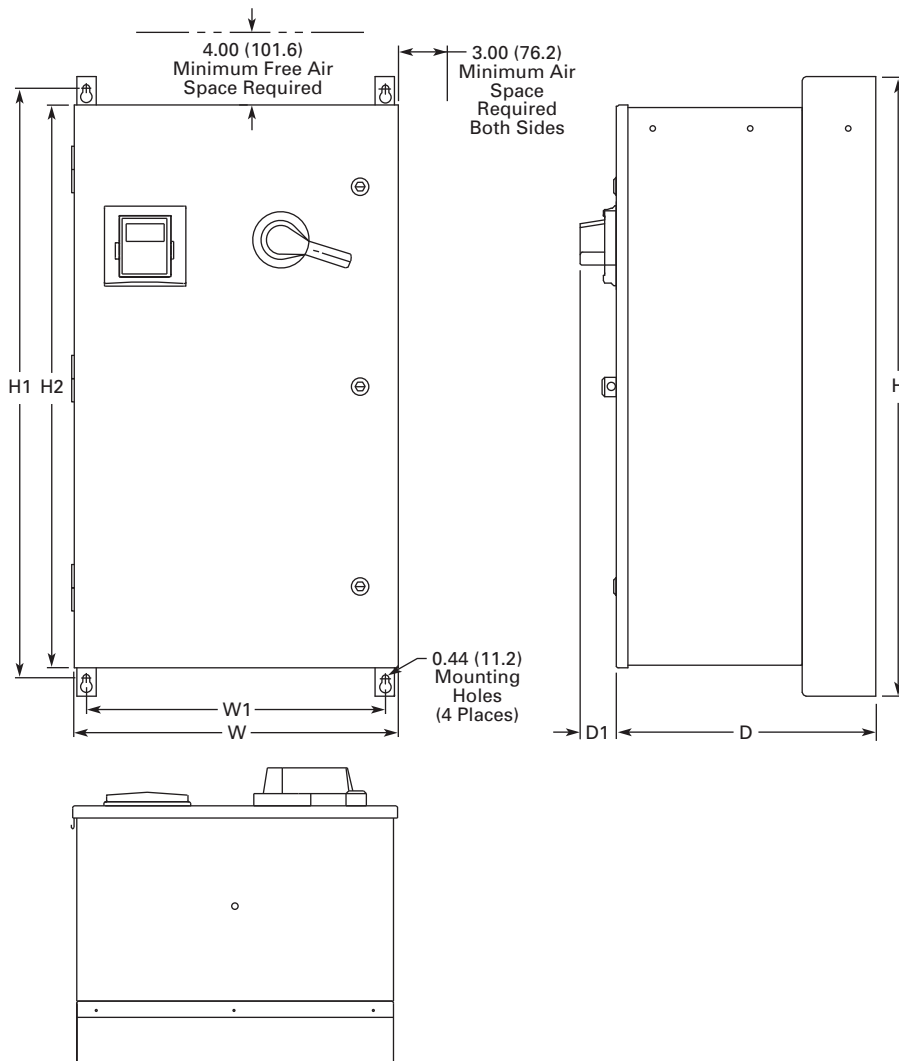

H	H1	H2	W	W1	D	D1	Approximate Weight Lbs (kg)	Approximate Shipping Weight Lbs (kg)
40.00 (1016.0)	38.00 (965.2)	36.35 (923.3)	20.92 (531.4)	19.30 (490.2)	16.76 (425.7)	2.34 (59.4)	185 (84)	229 (104)

# 36.6

## Adjustable Frequency Drives

CFX9000 Drives

Approximate Dimensions in Inches (mm)

### Enclosure Size C—UL Type 12

36

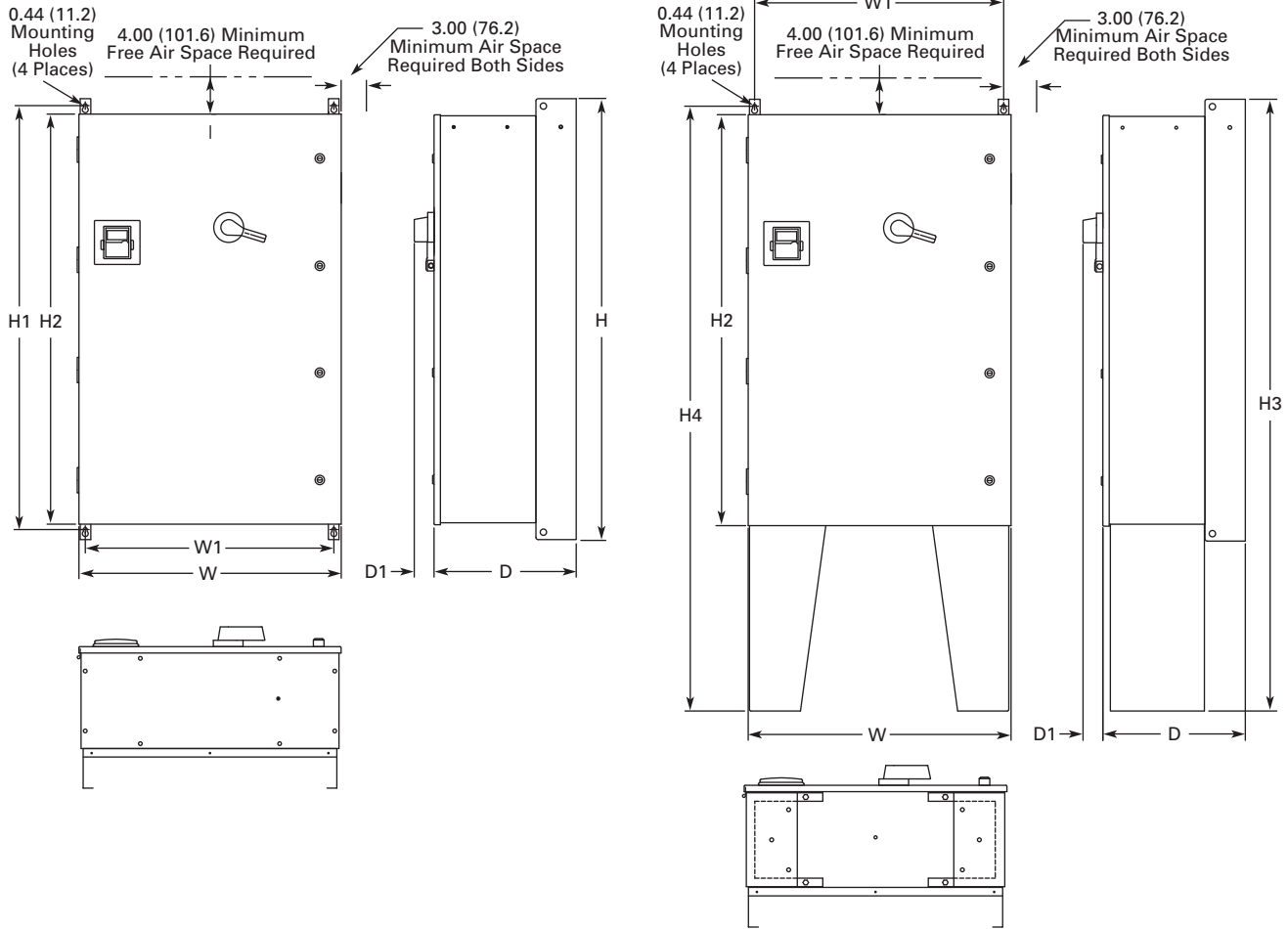

H	H1	H2	H3	H4	W	W1	D	D1	Approximate Weight Lbs (kg)	Approximate Shipping Weight Lbs (kg)
52.00 (1320.8)	50.00 (1270.0)	48.35 (1228.1)	72.00 (1828.8)	71.19 (1808.2)	30.92 (785.4)	29.30 (744.2)	16.78 (426.2)	2.34 (59.4)	320 (145)	435 (197)



Approximate Dimensions in Inches (mm)

## Enclosure Size B—UL Type 3R

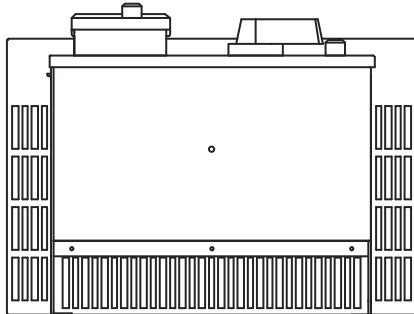
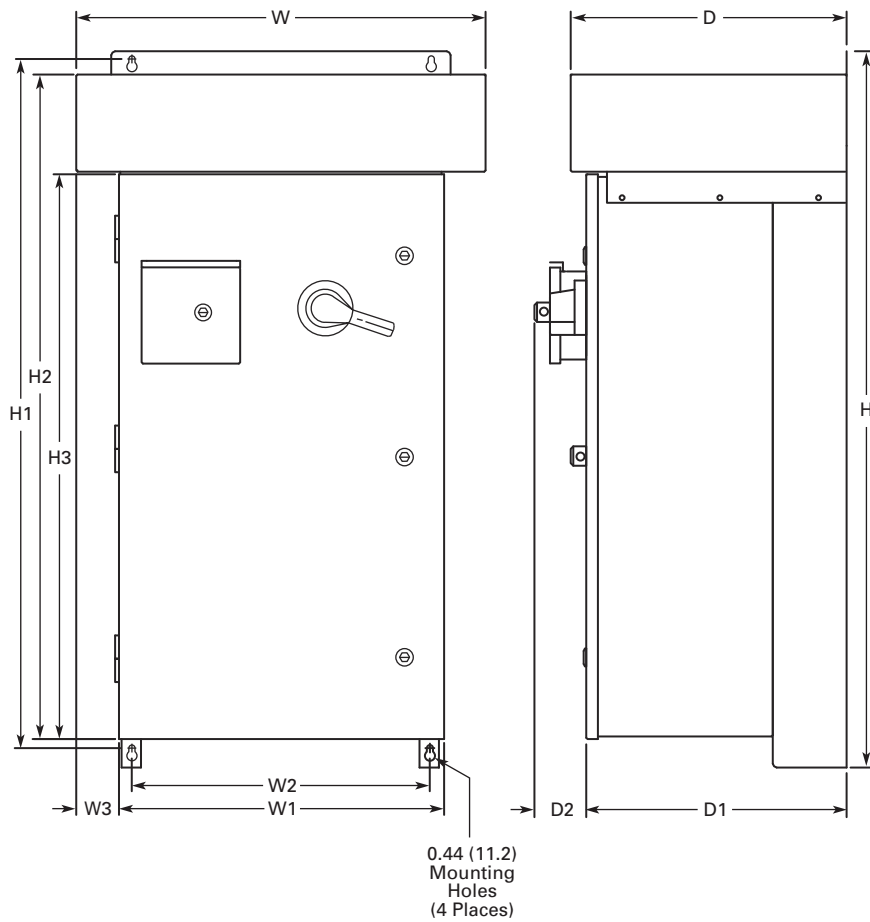

H	H1	H2	H3	W	W1	W2	W3	D	D1	D2	Approximate Weight Lbs (kg)	Approximate Shipping Weight Lbs (kg)
46.09 (1170.7)	44.45 (1129.0)	42.77 (1086.4)	36.35 (923.3)	26.31 (668.3)	20.92 (531.4)	19.30 (490.2)	2.69 (68.3)	17.74 (450.6)	16.76 (425.7)	3.31 (840.1)	235 (107)	290 (132)

# 36.6

## Adjustable Frequency Drives

CFX9000 Drives

Approximate Dimensions in Inches (mm)

### Enclosure Size C—UL Type 3R

36

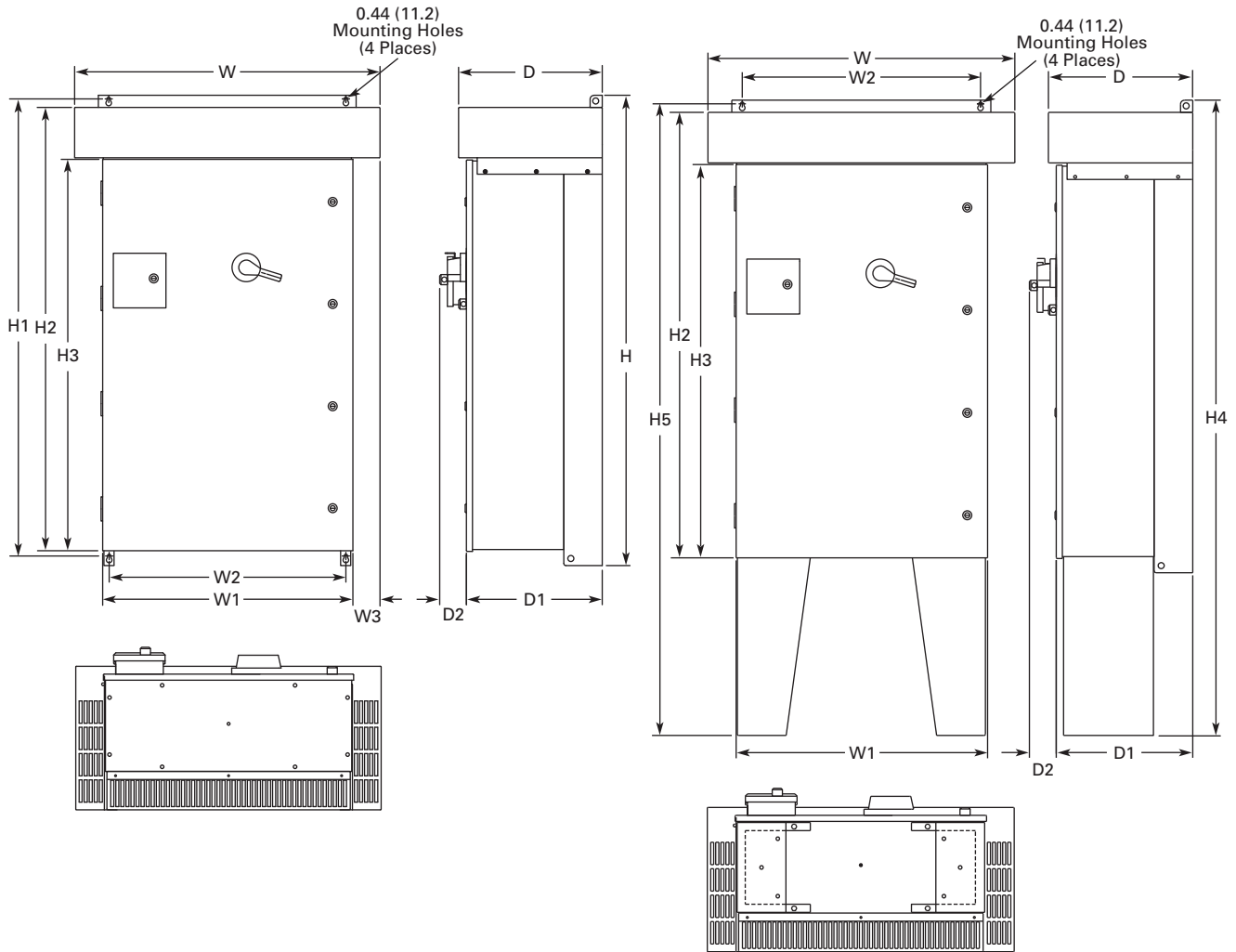

H	H1	H2	H3	H4	H5	W	W1	W2	W3	D	D1	D2	Approximate Weight Lbs (kg)	Approximate Shipping Weight Lbs (kg)
58.09 (1475.5)	56.45 (1433.8)	54.77 (1391.2)	48.35 (1228.1)	78.09 (1983.5)	77.64 (1972.1)	37.73 (958.3)	30.92 (785.4)	29.30 (744.2)	3.34 (84.8)	17.74 (450.6)	16.77 (426.0)	3.31 (840.1)	370 (168)	485 (220)

Approximate Dimensions in Inches (mm)

### Enclosure Size D—UL Type 3R

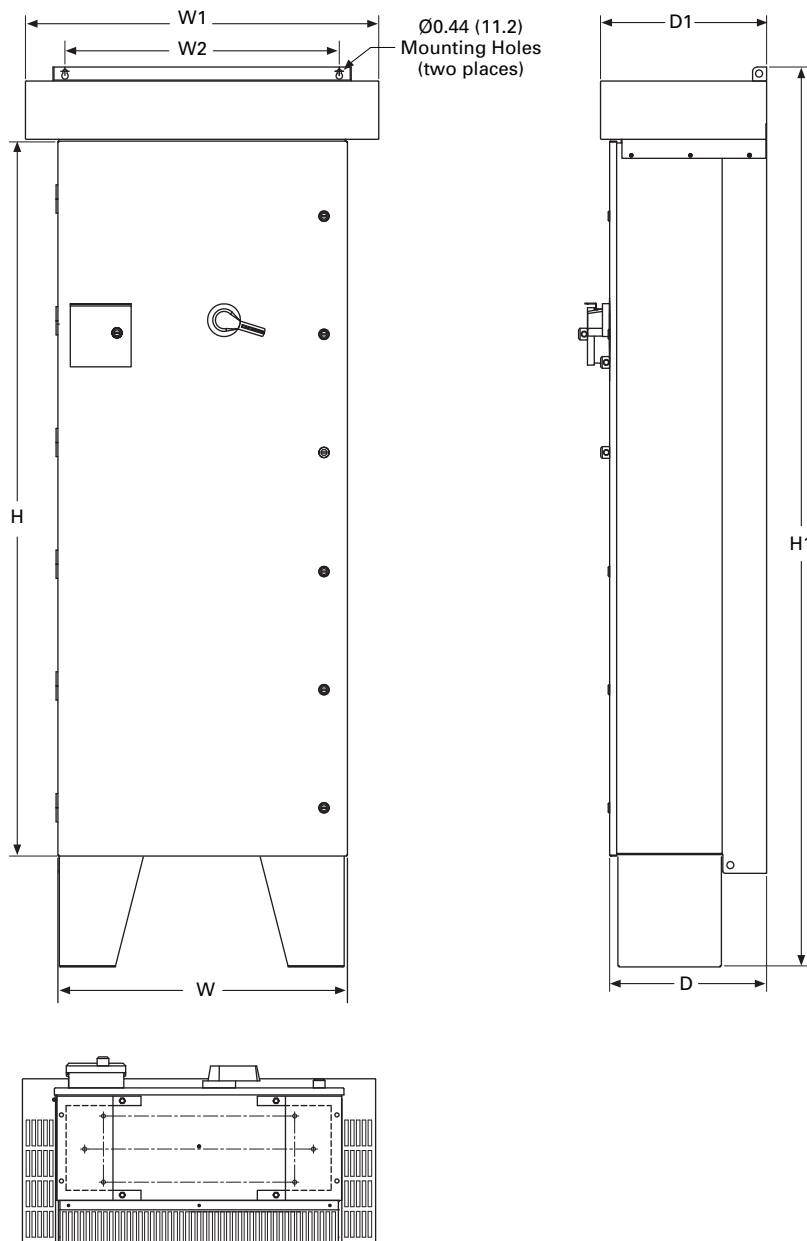

H	H1	W	W1	W2	D	D1	Approximate Shipping Weight Lbs (kg)
76.27 (1937.3)	96.00 (2438.4)	30.92 (784.4)	37.73 (958.3)	29.30 (744.2)	16.76 (424.7)	17.74 (450.6)	1000 (454)

#### Note

Shown with optional floor stands.

# 36.6

## Adjustable Frequency Drives

CFX9000 Drives

Approximate Dimensions in Inches (mm)

### Enclosure Size F

36

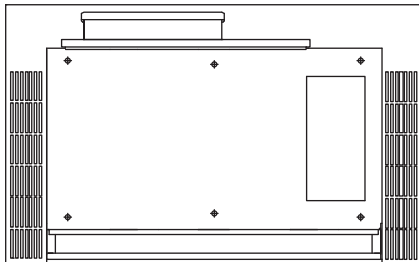
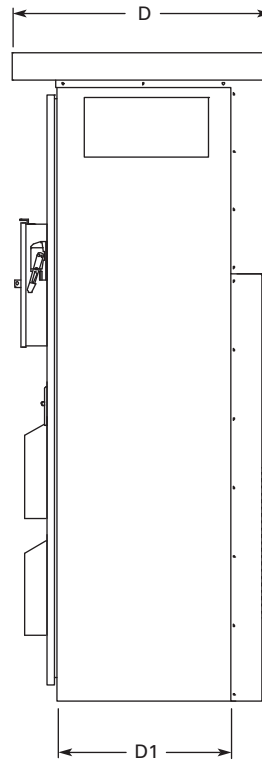
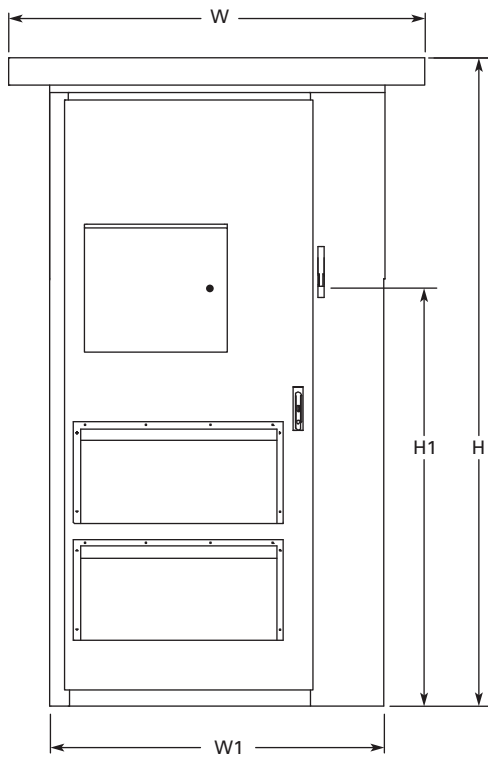

H	H1	W	W1	D	D1	Approximate Weight Lbs (kg)	Approximate Shipping Weight Lbs (kg)
93.58 (2376.9)	69.51 (1765.60)	60.00 (1524.0)	48.00 (1219.2)	37.50 (952.5)	26.00 (660.4)	1700 (771)	1850 (839)

Approximate Dimensions in Inches (mm)

## Enclosure Size 7

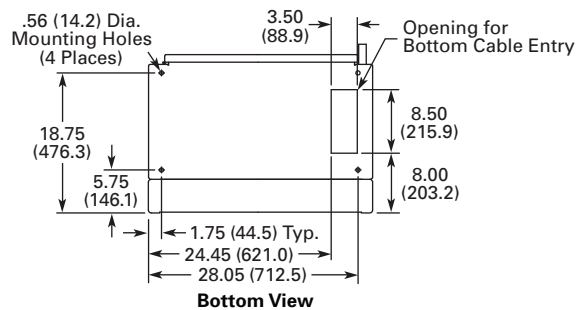
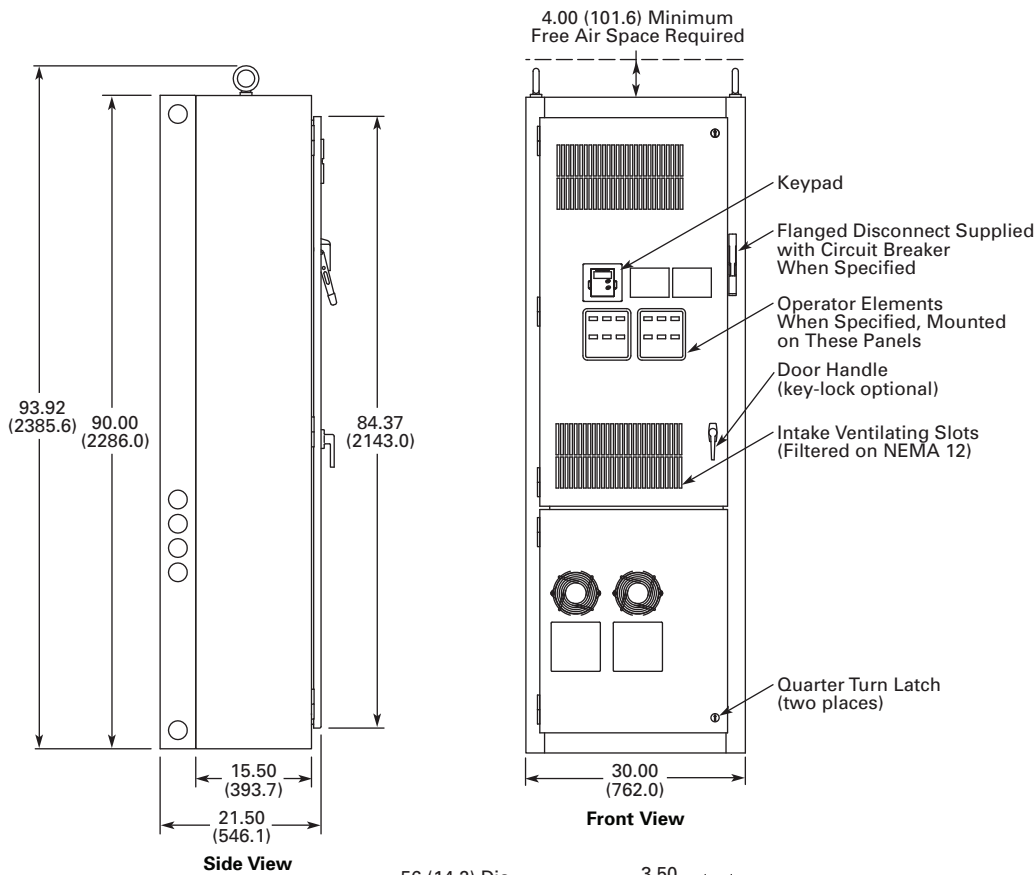
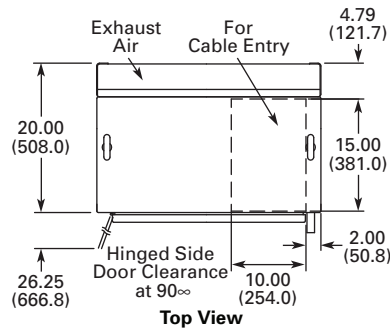

Construction: UL Type 1 Oversize  
Finish: Enclosure - ANSI 61 Gray (Light)

Approximate Shipping Weight  
Lbs (kg)

1000 (454)

# 36.6

## Adjustable Frequency Drives

CFX9000 Drives

Approximate Dimensions in Inches (mm)

### Enclosure Size 8

36

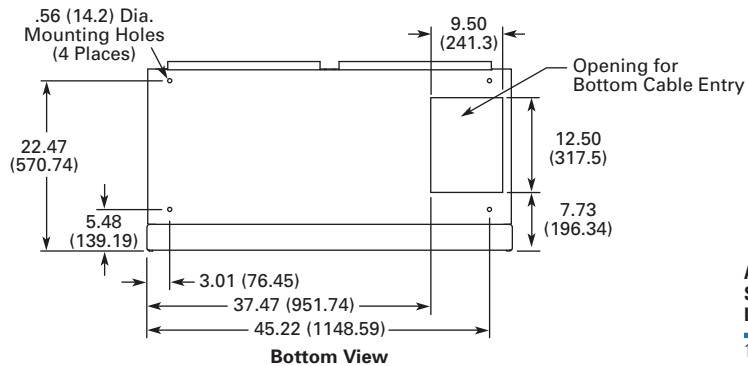
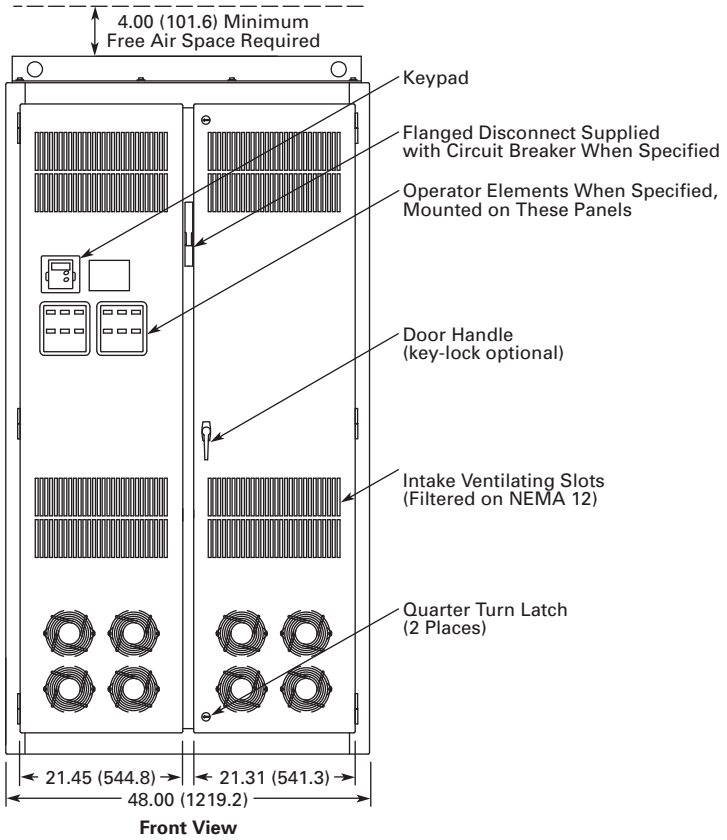
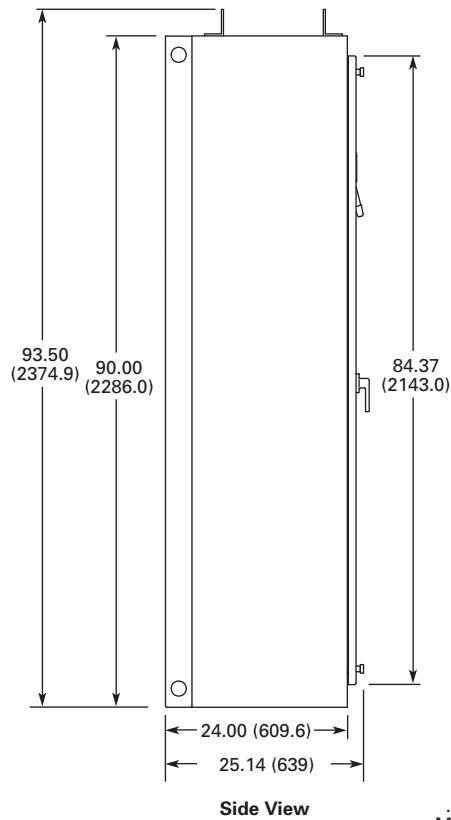
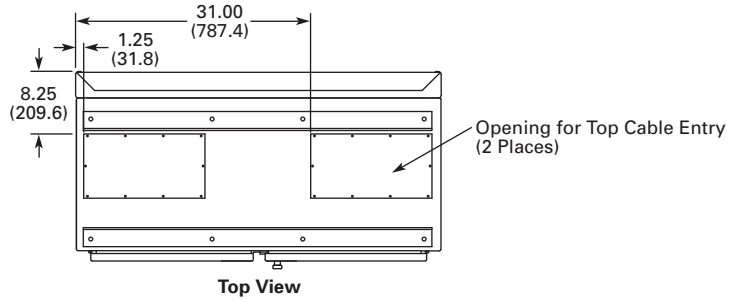

Construction: UL Type 1 Oversize  
Finish: Enclosure – ANSI 61 Gray (Light)

Approximate Shipping Weight  
Lbs (kg)

1400 (636)

Approximate Dimensions in Inches (mm)

### Enclosure Size 9

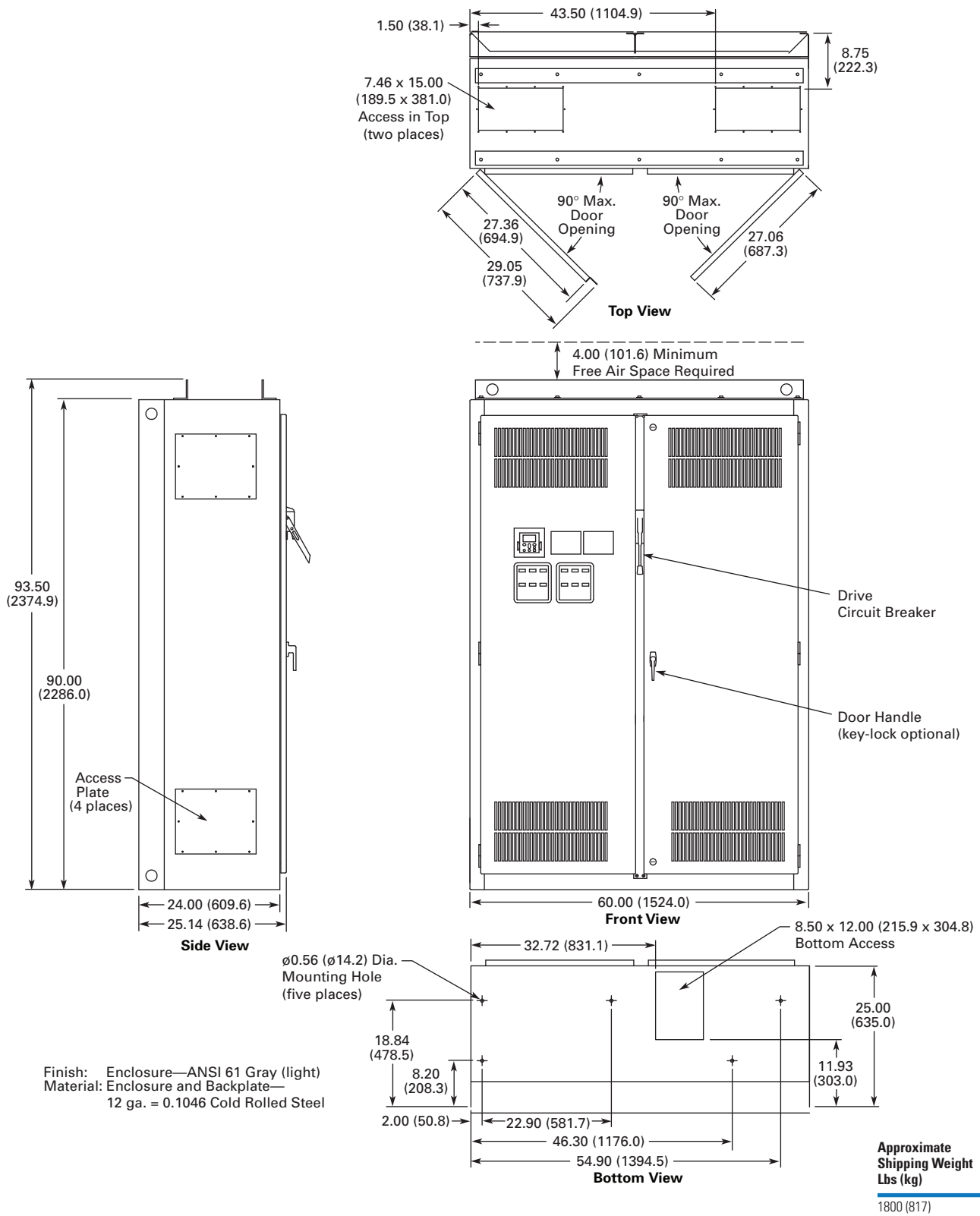

CPX9000 Enclosed Clean Power Drives



### Product Description

Eaton’s CPX9000 clean power drives use advanced 18-pulse clean power technology that significantly reduces line harmonics at the drive input terminals, resulting in one of the purest sinusoidal waveforms available.

The CPX9000 drive also delivers True Power Factor—in addition to reducing harmonic distortion, the CPX9000 drive prevents upstream transformer overheating and overloading of breakers and feeders, enabling the application of adjustable frequency drives on generators and other high impedance power systems.

All 9000X Series drives are constant torque rated and rated for either high overload ( $I_H$ ) or low overload ( $I_L$ ).  $I_H$  indicates 150% overload capacity for 1 minute out of 10 minutes.  $I_L$  indicates 110% overload capacity for 1 minute out of 10 minutes.

### Contents

<i>Description</i>	<i>Page</i>
CPX9000 Enclosed Clean Power Drives	
Application Description . . . . .	<b>V6-T36-193</b>
Features and Benefits . . . . .	<b>V6-T36-198</b>
Catalog Number Selection . . . . .	<b>V6-T36-199</b>
Product Selection . . . . .	<b>V6-T36-200</b>
Options . . . . .	<b>V6-T36-208</b>
Technical Data and Specifications . . . . .	<b>V6-T36-214</b>
Wiring Diagrams . . . . .	<b>V6-T36-216</b>
Dimensions . . . . .	<b>V6-T36-217</b>

### CPX9000 Enclosed Products

- **Standard Enclosed**—covers a wide range of the most commonly ordered options. Pre-engineering eliminates the lead time normally associated with customer specific options. Available configurations are listed on **Pages V6-T36-199** and **V6-T36-208** to **V6-T36-213**.
- **Modified Standard Enclosed**—applies to specific customer requirements that vary from the Standard Enclosed offering, such as the need for an additional indicating light or minor modifications to drawings. *Contact your local sales office for assistance in pricing and lead time.*

- **Custom Engineered**—for those applications with more unique or complex requirements, these are individually engineered to the customer’s needs. *Contact your local sales office for assistance in pricing and lead time.*



## Application Description

Designed to exceed the IEEE® 519-1992 requirements for harmonic distortion, the CPX9000 is the clear choice

for applications in the water, wastewater, HVAC, industrial and process industries where harmonics are a concern.

## What Are Harmonics?

**Take a perfect wave with a fundamental frequency of 60 Hz, which is close to what is supplied by the power company.**

### Perfect Wave

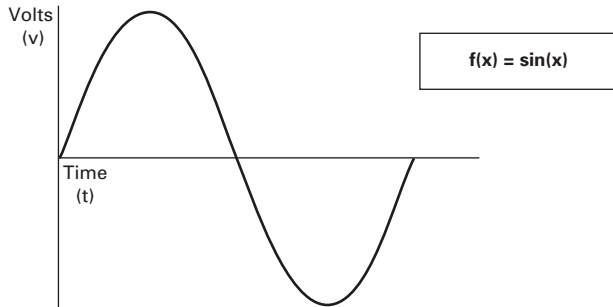

**Add a second wave that is five times the fundamental frequency—300 Hz (typical of frequency added to the line by a fluorescent light).**

### Second Wave

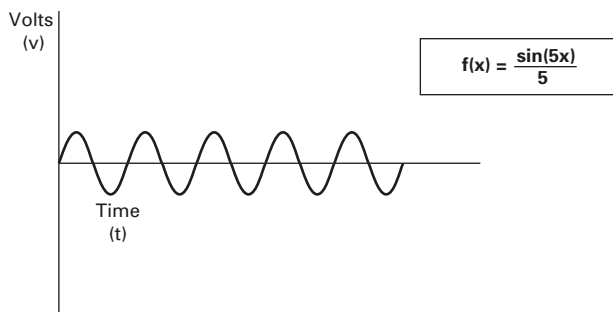

**Combine the two waves. The result is a 60 Hz supply rich in fifth harmonics.**

### Resulting Supply

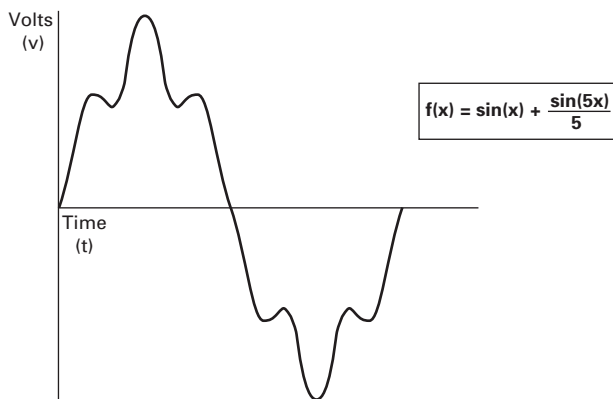

## What Causes Harmonics?

Harmonics are the result of nonlinear loads that convert AC line voltage to DC. Examples of equipment that are non-linear loads are listed below:

- AC variable frequency drives
- DC drives
- Fluorescence lighting, computers, UPS systems
- Industrial washing machines, punch presses, welders, etc.

## How Can Harmonics Due to VFDs Be Diminished?

By purchasing Eaton's 18-pulse CPX9000 drive that is guaranteed to meet IEEE Std. 519-1992 Harmonic Distortion Limits.

## What Are Linear Loads?

Linear loads are primarily devices that run across the line and do not add harmonics. Motors are prime examples. The downside to having large motor linear loads is that they draw more energy than a VFD, because of their inability to control motor speed. In most applications, there is a turn down valve used with the motor that will reduce the flow of the material, without significantly reducing the load to the motor. While this provides some measure of speed control, it is extremely inefficient.

## Why Be Concerned About Harmonics?

1. **Installation and utility costs increase.** Harmonics cause damage to transformers and lower efficiencies due to the IR loss. These losses can become significant and can have a dramatic effect on the HVAC systems that are controlling the temperatures of the building where the transformer and drive equipment reside.
2. **Downtime and loss of productivity.** Telephones and data transmissions links may not be guaranteed to work on the same power grids polluted with harmonics.
3. **Downtime and nuisance trips of drives and other equipment.** Emergency generators have up to three times the impedance that is found in a conventional utility source. Thus the harmonic voltage distortion can be up to three times as large, causing risk of operation problems.
4. **Larger motors must be used.** Motors running across the line that are connected on polluted power distribution grids can overheat or operate at lower efficiency due to harmonics.
5. **Higher installation costs.** Transformers and power equipment must be oversized to accommodate the loss of efficiencies. This is due to the harmonic currents circulating through the distribution without performing useful work.

#### How Does a VFD Convert Three-Phase AC to a Variable Output Voltage and Frequency?

The six-pulse VFD: The majority of all conventional drives that are built consist of a six-pulse configuration. The figure below represents a six-diode rectifier design that converts three-phase utility power to DC. The inverter section uses IGBTs to convert DC power to a simulated AC sine wave that can vary in frequency from 0–320 Hz.

The six-pulse VFD drive creates harmonic current distortion. The harmonic current that is created is energy that can not be used by customers and causes external heat and losses to all components including other drives that are on the same power distribution. See the curve below showing a 500 hp drive with 167A of damaging harmonic current.

#### Six-Diode Rectifier Design

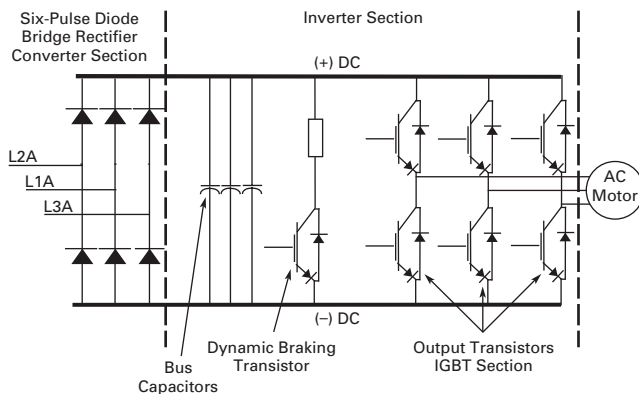

#### Guidelines of Meeting IEEE Std. 519-1992 Harmonic Distortion Limits

The IEEE 519-1992 Specification is a standard that provides guidelines for commercial and industrial

users that are implementing medium and low voltage equipment.

#### Maximum Harmonic Current Distortion in % of the Fundamental (120V through 69,000V)

Isc/I <sub>L</sub>	Harmonic Order (Odd Harmonics)					TDD
	h<11	11≤h<17	17≤h<23	23≤h<35	35≤h	
<20	4.0	2.0	1.5	0.6	0.3	5.0
20<50	7.0	3.5	2.5	1.0	0.5	8.0
50<100	10.0	4.5	4.0	1.5	0.7	12.0
100<1000	12.0	5.5	5.0	2.0	1.0	15.0
>1000	15.0	7.0	6.0	2.5	1.4	20.0

The ratio  $I_{sc}/I_L$  is the ratio of the short-circuit current available at the point of common coupling (PCC), to the maximum fundamental load current. Consequently, as the size of the user load decreases with respect to the size of the system, the percentage of harmonic current that the user is allowed to inject into the utility system increases.

#### Notes

TDD = Total demand distortion is the harmonic current distortion in percent of the maximum demand load current (15 or 30 minute demand).

$I_{sc}$  = Maximum short circuit current at the PCC not counting motor contribution.

$I_L$  = Maximum demand load current for all of the connected loads (fundamental frequency component) at the PCC. All of the limits are measured at a point of common coupling.

#### 500 hp Six-Pulse Nonproductive Harmonic Current

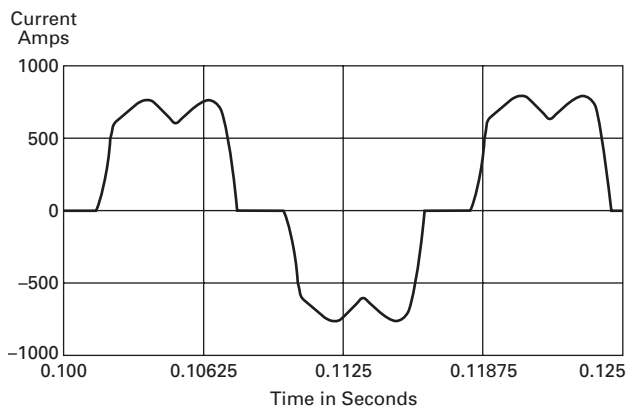

#### 500 hp Six-Pulse Nonproductive Harmonic Current

##### Six-Pulse Circuit

Current harmonics		
$I_1 = 100\%$	$I_{11} = 6.10\%$	$I_{19} = 1.77\%$
$I_5 = 22.5\%$	$I_{13} = 4.06\%$	$I_{23} = 1.12\%$
$I_7 = 9.38\%$	$I_{17} = 2.26\%$	$I_{25} = 0.86\%$
Power = 500 hp		
Harmonic current = 167 amps		

## One-Line Diagram for Harmonic Analysis

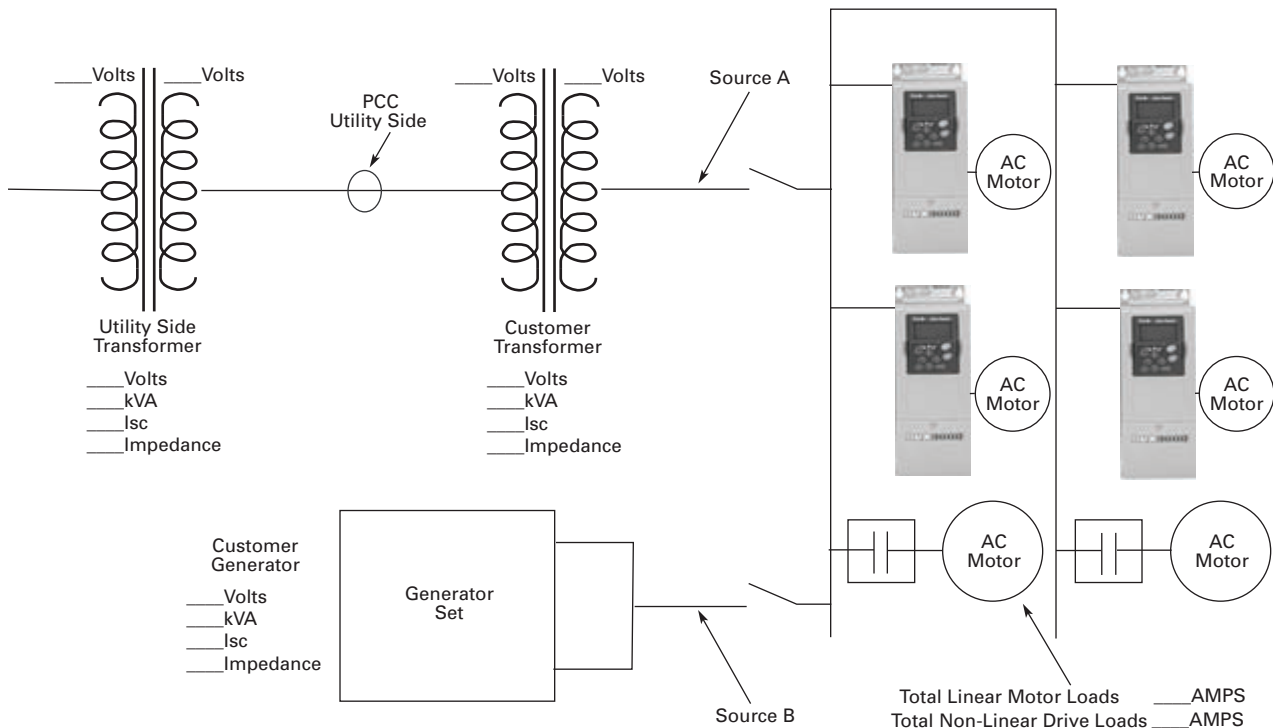

**The best way to estimate AFD harmonic contribution to an electrical system is to perform a harmonic analysis based on known system characteristics. The one-line in this figure would provide the data to complete the calculations.**

**Terms**

- PCC (Point of Common Coupling) is defined as the electrical connecting point between the utility and multiple customers per the specifications in IEEE 519
- POA (Point of Analysis) is defined as where the harmonic calculations are taken

An oscilloscope can make all measurements at the PCC or POA do an on-site harmonic evaluation.

**Harmonic Reduction Methods to Meet IEEE 519****1. Line Reactor**

A line reactor is a three-phase series inductance on the line side of an AFD. If a line reactor is applied on all AFDs, it is possible to meet IEEE guidelines where 10–25% of system loads are AFDs, depending on the stiffness of the line and the value of line reactance. Line reactors are available in various values of impedance, most typically 1–1.5%, 3% and 5%.

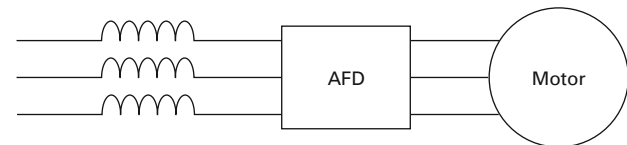
**Line Reactor****Advantages**

- Low cost
- Can provide moderate reduction in voltage and current harmonics
- Available in various values of impedance
- Provides increased input protection for AFD and its semiconductors from line transients

**Disadvantages**

- May not reduce harmonic levels to below IEEE 519-1992 guidelines
- Voltage drop due to IR loss

#### 2. 12-Pulse Converters

A 12-pulse converter incorporates two separate AFD input semiconductor bridges, which are fed from 30° phase shifted power sources with identical impedance. The sources may be two isolation transformers, where one is a delta/wye design (which provides the phase shift) and

the second a delta/delta design (which does not phase shift). The 12-pulse arrangement allows the harmonics from the first converter to cancel the harmonics of the second. Up to approximately 85% reduction of harmonic current and voltage distortion may be achieved (over standard

six-pulse converter). This permits a facility to use a larger percentage of AFD loads under IEEE 519-1992 guidelines than allowable using line reactors or DC chokes. A harmonic analysis is required to guarantee compliance with guidelines.

#### Basic 12-Pulse Rectifier with "Phase Shifting" Transformer

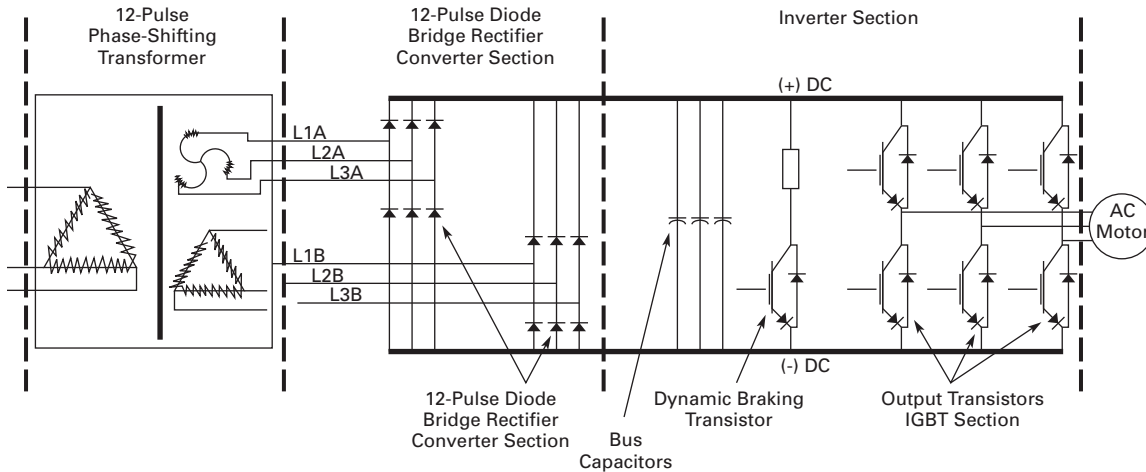

#### 500 hp 480V Drive with 12-Pulse Rectifier

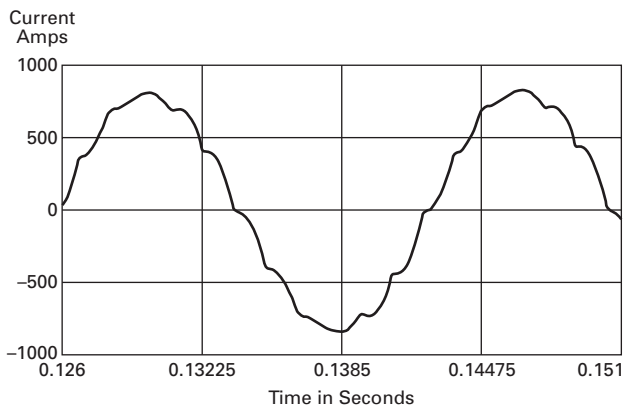

#### 500 hp 480V Drive with 12-Pulse Rectifier

##### 12-Pulse Circuit

##### Current harmonics

$I_1 = 100\%$	$I_{11} = 4.19\%$	$I_{19} = 0.06\%$
$I_5 = 1.25\%$	$I_{13} = 2.95\%$	$I_{23} = 0.87\%$
$I_7 = 0.48\%$	$I_{17} = 0.21\%$	$I_{25} = 0.73\%$

Power = 500 hp

$H_c = 66.2$  amps

##### Advantages

- Moderate cost, although significantly more than reactors or chokes
- Substantial reduction (up to approx. 85%) in voltage and current harmonics
- Provides increased input protection for AFD and its semiconductors from line transients

##### Disadvantages

- Impedance matching of phase shifted sources is critical to performance
- Transformers often require separate mounting or larger AFD enclosures
- May not reduce distribution harmonic levels to below IEEE 519-1992 guidelines
- Cannot retrofit for most AFDs

### 3. Clean Power Drives

When the total load is of non-linear, the greatest harmonic mitigation is required. Under these conditions, the currents drawn from the supply need to be sinusoidal and "clean" such that system interference and additional losses are negligible. Eaton's CPX9000 clean power drive uses a phase-shifting auto-transformer with delta-connected winding. Three of the output phases

are advanced and three are retarded. The remaining three phases of this nine-phase supply are in phase with the incoming line. This results in nine separate phases. In this type of configuration, the total required kVA rating of the transformer is only 48% of a drive rate isolation transformer. A traditional isolated transformer system, with multipulse windings, would require the full kVA

rating to be supported, which is more common in an MV step-down transformer.

The integrated 18-pulse clean power drive, with near sine wave input current and low harmonics will meet the requirements of IEEE 519-1992 under all practical operating conditions. The comparisons with six-pulse and 12-pulse systems are shown, see **Pages V6-T36-194, V6-T36-196 and V6-T36-197.**

#### Basic 18-Pulse Rectifier with Phase Shifting Transformer

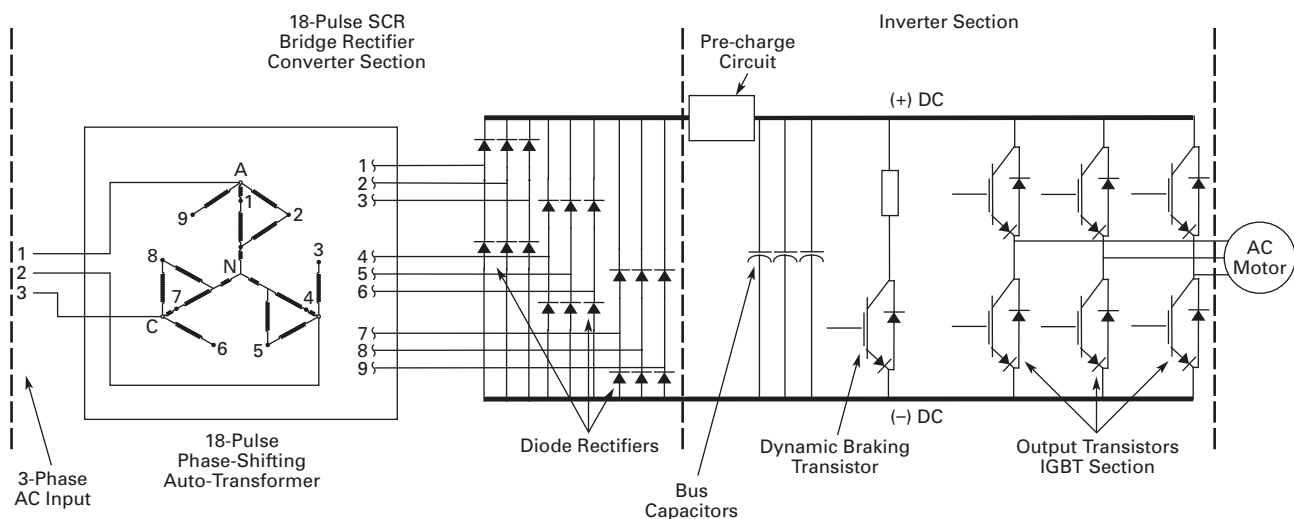

#### 500 hp 480V Drive with 18-Pulse Rectifiers

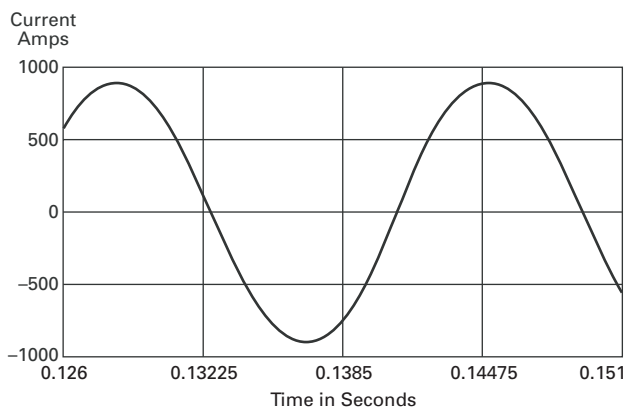

#### 500 hp 480V Drive with 18-Pulse Rectifiers

##### 18-Pulse Clean Power

###### Current harmonics

$I_1 = 100\%$	$I_{11} = 0.24\%$	$I_{19} = 1.00\%$
$I_5 = 0.16\%$	$I_{13} = 0.10\%$	$I_{23} = 0.01\%$
$I_7 = 0.03\%$	$I_{17} = 0.86\%$	$I_{25} = 0.01\%$

Power = 500 hp

$I_c = 24$  amps

##### Advantages

- Virtually guarantees compliance with IEEE 519-1992
- Provides increased input protection for AFD and its semiconductors from line transients
- Up to four times the harmonic reduction of 12-pulse methods
- Smaller transformer than isolation transformer used in 12-pulse converter

##### Disadvantages

- Not as cost-effective as some other methods at small (<50) horsepower

# 36.7

## Adjustable Frequency Drives

### CPX9000 Drives

36

#### Features and Benefits

CPX9000 clean power drive features include:

- Space optimized enclosure
- Simple layout for power options
- Type 1, NEMA 12 with gaskets and filters, Type 3R
- Input voltage: 480V, 208V, 575V
- Complete range of control, network and power options

- Horsepower range:
  - 480V, 25–800 hp (consult factory for larger sizes)
  - 208/230V, 25–200 hp
  - 575V, 25–800 hp (consult factory for larger sizes)
- Over 15 years of 18-pulse clean power experience
- 65 kAIC Standard at 480V and 208V
- 100 kAIC optional

#### Standards and Certifications

UL 508C tested, listed and approved.



#### Product Identification

Type 1, 25–150 hp (30 x 90 x 21.50)

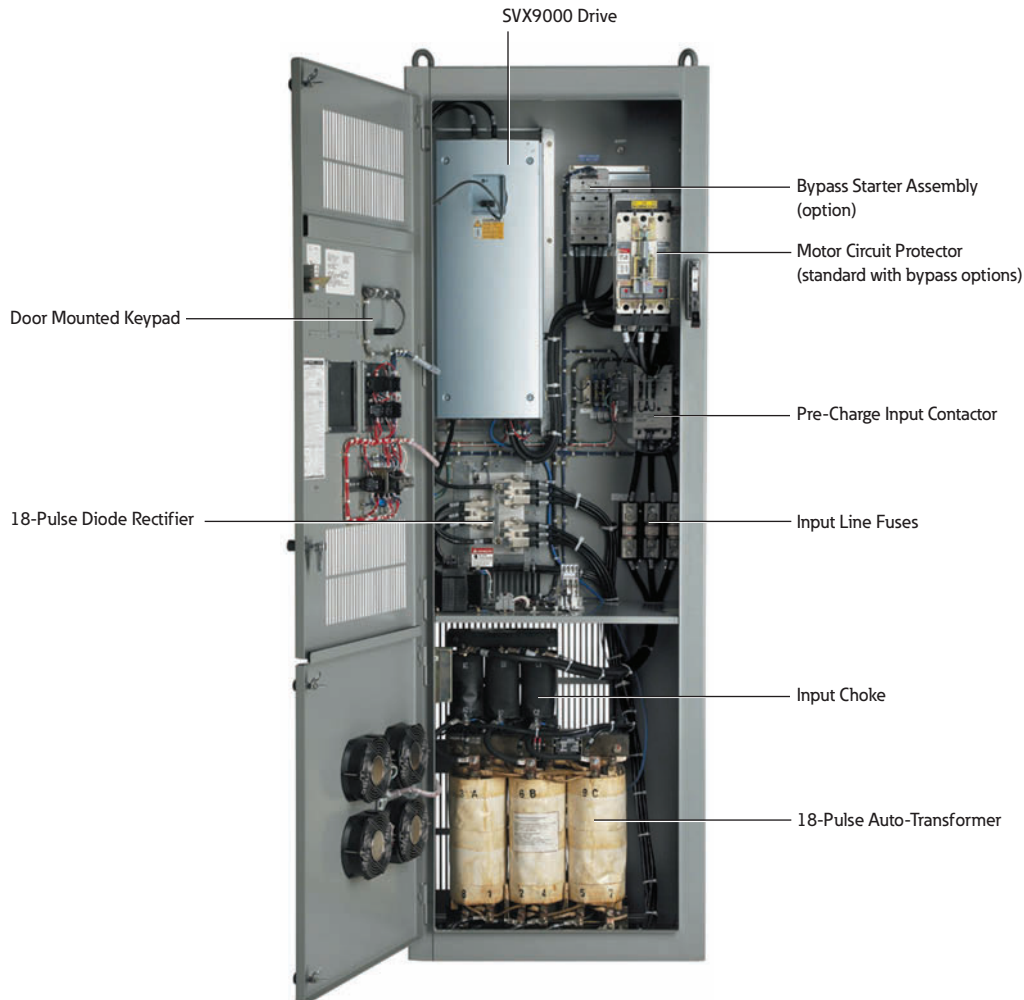

## Catalog Number Selection

## CPX9000 Enclosed Drive

CPX 100 1 4 A A

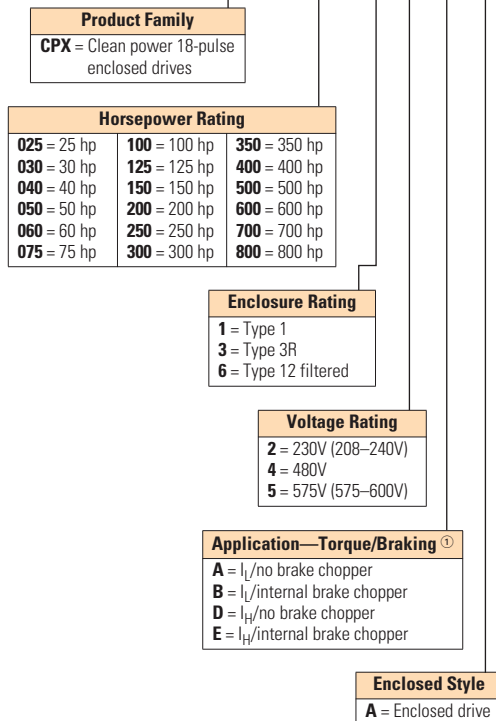

Build options alphabetically and numerically.

Enclosed Options ②③④		Type
<b>K1</b>	Door-mounted speed potentiometer ⑤	Control
<b>K2</b>	Door-mounted speed potentiometer with HOA selector switch ⑤	Control
<b>K3</b>	3–15 psig follower	Control
<b>K4</b>	HAND/OFF/AUTO switch 0.87-inch (22 mm)	Control
<b>K5</b>	MANUAL/AUTO reference switch 0.87-inch (22 mm)	Control
<b>K6</b>	START/STOP pushbuttons 0.87-inch (22 mm)	Control
<b>KF</b>	Bypass test switch for RA and RB	Add. bypass
<b>K0</b>	Standard elapsed time meter	Control
<b>L1</b>	Power, RUN and fault pilot lights	Light
<b>L2</b>	Bypass pilot lights for RA, RB, bypass options	Add. bypass
<b>LE</b>	Red RUN light	Light
<b>P1</b>	Input disconnect	Input
<b>P8</b>	Surge protective device	Input
<b>PE</b>	Output contactor	Output
<b>PF</b>	Output filter	Output
<b>PG</b>	MotoRx (up to 600 ft [182.9m]) 1000 V/μS DV/DT filter	Output
<b>PH</b>	Single overload relay	Output
<b>PI</b>	Dual overload relays	Output
<b>PN</b>	Dual overloads for bypass	Add. bypass
<b>RA</b>	Manual HOA bypass controller	Bypass
<b>RB</b>	Manual IOB bypass controller	Bypass
<b>RC</b>	Auto transfer HOA bypass controller	Bypass
<b>RD</b>	Auto transfer IOB bypass controller	Bypass
<b>RG</b>	Reduced voltage starter for bypass	Bypass
<b>S7</b>	10.00-inch (254.0 mm) expansion	Enclosure
<b>S8</b>	20.00-inch (508.0 mm) expansion	Enclosure
<b>S9</b>	Space heater	Enclosure

Communication Options ⑥	
<b>C2</b> = Modbus®	<b>CA</b> = Johnson Controls N2
<b>C3</b> = PROFIBUS® DP	<b>CI</b> = Modbus TCP/Ethernet IP
<b>C4</b> = LonWorks®	<b>CJ</b> = BACnet
<b>C5</b> = Profibus DP (D9 connector)	<b>D3</b> = RS-232 with D9 connection
<b>C6</b> = CANopen (slave)	
<b>C7</b> = DeviceNet™	
<b>C8</b> = Modbus (D9 Type connector)	

Control Options
<b>B1</b> = 6 DI, 1 ext +24 Vdc/ext +24 Vdc
<b>B2</b> = 1 RO (NC/NO), 1 RO (NO), 1 therm
<b>B4</b> = 1 AI (mA isolated), 2 AO (mA isolated), 1 ext +24 Vdc/EXT +24 Vdc
<b>B5</b> = 3 RO (NO)
<b>B8</b> = 1 ext +24 Vdc/ext +24 Vdc, 3 Pt100
<b>B9</b> = 1 RO (NO), 5 DI 42–240 Vac input

Engineered Options
<b>HT</b> High temperature rating for 50°C (FR10 and above) ⑦
<b>VB</b> Varnished boards

## Notes

- ① Brake chopper is standard in drives up to 30 hp I<sub>H</sub> or 40 hp I<sub>L</sub> at 480V. It is optional in larger drives.
- ② Local/remote keypad is included as the standard control panel.
- ③ Some options are voltage and/or horsepower specific. Consult your Eaton representative for details.
- ④ See **Pages V6-T36-210** and **V6-T36-211** for complete descriptions.
- ⑤ Includes local/remote speed reference switch.
- ⑥ See **Pages V6-T36-208** and **V6-T36-209** for complete descriptions.
- ⑦ Consult Eaton for availability.



### Product Selection

#### When Ordering

• Select a base catalog number that meets the application requirements—nominal horsepower, voltage and enclosure rating. (The enclosed drive's continuous output amp rating should be equal to or greater than the motor's full load amp rating.) The base-enclosed package includes a standard drive, door-mounted alphanumeric panel and enclosure.

• The CPX9000 product uses the term High Overload ( $I_H$ ) in place of the term Constant Torque (CT). Likewise, Low Overload ( $I_L$ ) is used in place of the term Variable Torque (VT). The new terms are a more precise description of the rating. The older terms included ambient temperature ratings in addition to overload ratings. In order to minimize enclosure size and offer the highest ambient temperature

rating, overload and temperature ratings are now treated separately. Ambient temperature ratings are shown in the table below. Consult the factory for 50°C ratings of FR10 and above.

#### Ambient Temperature Ratings

Frame Size	$I_H$	$I_L$
FR4–FR9	50°C	50°C
FR10 and above	40°C	40°C

- If dynamic brake chopper or control/communication option is desired, change the appropriate code in the base catalog number.
- All of the programming is exactly the same as the standard SVX9000 drive.
- Select enclosed options. Add the codes as suffixes to the base catalog number in alphabetical and numeric order.

### 208/230V Drives

#### CPX9000 Drive



#### CPX9000 Base Drive Type 1

Enclosure Size ①	hp ②	Current (A)	Chassis Frame	Base Catalog Number ③
<b>Low Overload Drive</b>				
7	25	75	FR7	<b>CPX02512AA</b>
	30	88	FR7	<b>CPX03012AA</b>
	40	114	FR7	<b>CPX04012AA</b>
	50	140	FR8	<b>CPX05012AA</b>
	60	170	FR8	<b>CPX06012AA</b>
	75	205	FR8	<b>CPX07512AA</b>
8	100	300	FR9	<b>CPX10012AA</b>
9	125	340	FR8T	<b>CPX12512AA</b>
	150	410	FR8T	<b>CPX15012AA</b>
10	200	522	FR9T	<b>CPX20012AA</b>
<b>High Overload Drive</b>				
7	25	75	FR7	<b>CPX02512DA</b>
	30	88	FR7	<b>CPX03012DA</b>
	40	114	FR8	<b>CPX04012DA</b>
	50	140	FR8	<b>CPX05012DA</b>
	60	170	FR8	<b>CPX06012DA</b>
8	75	205	FR9	<b>CPX07512DA</b>
9	100	300	FR8T	<b>CPX10012DA</b>
	125	340	FR8T	<b>CPX12512DA</b>
10	150	410	FR9T	<b>CPX15012DA</b>
	200	522	FR9T	<b>CPX20012DA</b>

#### Notes

① See enclosure dimensions beginning on **Page V6-T36-217**.

② hp ratings are provided as a guideline. Drives should be sized per motor nameplate FLA.

③ The 18-pulse clean power assembly includes a standard drive, door-mounted local/remote keypad and enclosure.



## CPX9000 Drive



## CPX9000 Base Drive NEMA 12 Filtered

Enclosure Size <sup>①</sup>	hp <sup>②</sup>	Current (A)	Chassis Frame	Base Catalog Number <sup>③</sup>
<b>Low Overload Drive</b>				
7	25	75	FR7	CPX02562AA
	30	88	FR7	CPX03062AA
	40	114	FR7	CPX04062AA
	50	140	FR8	CPX05062AA
	60	170	FR8	CPX06062AA
	75	205	FR8	CPX07562AA
8	100	300	FR9	CPX10062AA
9	125	340	FR8T	CPX12562AA
	150	410	FR8T	CPX15052AA
10	200	522	FR9T	CPX20062AA
<b>High Overload Drive</b>				
7	25	75	FR7	CPX02562DA
	30	88	FR7	CPX03062DA
	40	114	FR8	CPX04062DA
	50	140	FR8	CPX05062DA
	60	170	FR8	CPX06062DA
	75	205	FR8	CPX07562DA
8	100	300	FR9	CPX10062DA
9	125	340	FR8T	CPX12562DA
	150	410	FR8T	CPX15062DA
10	200	522	FR9T	CPX20062DA

CPX9000 Base Drive Type 3R <sup>④</sup>

Enclosure Size <sup>①</sup>	hp <sup>②</sup>	Current (A)	Chassis Frame	Base Catalog Number <sup>③</sup>
<b>Low Overload Drive</b>				
7	25	75	FR7	CPX02532AA
	30	88	FR7	CPX03032AA
	40	114	FR7	CPX04032AA
	50	140	FR8	CPX05032AA
	60	170	FR8	CPX06032AA
	75	205	FR8	CPX07532AA
8	100	300	FR9	CPX10032AA
9	125	340	FR8T	CPX12532AA
<b>High Overload Drive</b>				
7	25	75	FR7	CPX02532DA
	30	88	FR7	CPX03032DA
	40	114	FR8	CPX04032DA
	50	140	FR8	CPX05032DA
	60	170	FR8	CPX06032DA
	75	205	FR8	CPX07532DA
8	100	300	FR9	CPX10032DA
9	125	340	FR8T	CPX12532DA

**Notes**

- ① See enclosure dimensions beginning on **Page V6-T36-217**.
- ② hp ratings are provided as a guideline. Drives should be sized per motor nameplate FLA.
- ③ The 18-pulse clean power assembly includes a standard drive, door-mounted local/remote keypad and enclosure.
- ④ All Type 3R drives use the Size F enclosure.

#### 480V Drives

36

#### CPX9000 Drive



#### CPX9000 Base Drive Type 1

Enclosure Size <sup>①</sup>	hp <sup>②</sup>	Current (A)	Chassis Frame	Base Catalog Number <sup>③</sup>
<b>Low Overload Drive</b>				
7	25	38	FR6	CPX02514BA
	30	46	FR6	CPX03014BA
	40	61	FR6	CPX04014BA
	50	72	FR7	CPX05014AA
	60	87	FR7	CPX06014AA
	75	105	FR7	CPX07514AA
	100	140	FR8	CPX10014AA
	125	170	FR8	CPX12514AA
	150	205	FR8	CPX15014AA
8	200	261	FR9	CPX20014AA
	250	300	FR9	CPX25014AA
9	300	385	FR10	CPX30014AA
	350	460	FR10	CPX35014AA
	400	520	FR10	CPX40014AA
10	500	590	FR11	CPX50014AA
	550	650	FR11	CPX55014AA
	600	730	FR11	CPX60014AA
11	650	820	FR11	CPX65014AA
	700	920	FR12	CPX70014AA
	800	1030	FR12	CPX80014AA
<b>High Overload Drive</b>				
7	25	38	FR6	CPX02514EA
	30	46	FR6	CPX03014EA
	40	61	FR7	CPX04014DA
	50	72	FR7	CPX05014DA
	60	87	FR7	CPX06014DA
	75	105	FR8	CPX07514DA
	100	140	FR8	CPX10014DA
	125	170	FR8	CPX12514DA
	8	150	205	FR9
200		245	FR9	CPX20014DA
9	250	300	FR10	CPX25014DA
	300	385	FR10	CPX30014DA
	350	460	FR10	CPX35014DA
10	400	520	FR11	CPX40014DA
	500	590	FR11	CPX50014DA
	550	650	FR11	CPX55014DA
11	600	720	FR12	CPX60014DA
	650	820	FR12	CPX65014DA
	700	840	FR12	CPX70014DA

#### Notes

- ① See enclosure dimensions beginning on **Page V6-T36-217**.
- ② hp ratings are provided as a guideline. Drives should be sized per motor nameplate FLA.
- ③ The 18-pulse clean power assembly includes a standard drive, door-mounted local/remote keypad and enclosure.

## CPX9000 Drive



## CPX9000 Base Drive NEMA 12 Filtered

Enclosure Size <sup>①</sup>	hp <sup>②</sup>	Current (A)	Chassis Frame	Base Catalog Number <sup>③</sup>
<b>Low Overload Drive</b>				
7	25	38	FR6	CPX02564BA
	30	46	FR6	CPX03064BA
	40	61	FR6	CPX04064BA
	50	72	FR7	CPX05064AA
	60	87	FR7	CPX06064AA
	75	105	FR7	CPX07564AA
	100	140	FR8	CPX10064AA
	125	170	FR8	CPX12564AA
	150	205	FR8	CPX15064AA
8	200	261	FR9	CPX20064AA
	250	300	FR9	CPX25064AA
9	300	385	FR10	CPX30064AA
	350	460	FR10	CPX35064AA
	400	520	FR10	CPX40064AA
10	500	590	FR11	CPX50064AA
	550	650	FR11	CPX55064AA
	600	730	FR11	CPX60064AA
11	650	820	FR11	CPX65064AA
	700	920	FR12	CPX70064AA
	800	1030	FR12	CPX80064AA
<b>High Overload Drive</b>				
7	25	38	FR6	CPX02564EA
	30	46	FR6	CPX03064EA
	40	61	FR7	CPX04064DA
	50	72	FR7	CPX05064DA
	60	87	FR7	CPX06064DA
	75	105	FR8	CPX07564DA
	100	140	FR8	CPX10064DA
	125	170	FR8	CPX12564DA
	8	150	205	FR9
200		245	FR9	CPX20064DA
9	250	300	FR10	CPX25064DA
	300	385	FR10	CPX30064DA
	350	460	FR10	CPX35014DA
10	400	520	FR11	CPX40064DA
	500	590	FR11	CPX50064DA
	550	650	FR11	CPX55064DA
11	600	720	FR12	CPX60064DA
	650	820	FR12	CPX65064DA
	700	840	FR12	CPX70064DA

**Notes**

① See enclosure dimensions beginning on **Page V6-T36-217**.

② hp ratings are provided as a guideline. Drives should be sized per motor nameplate FLA.

③ The 18-pulse clean power assembly includes a standard drive, door-mounted local/remote keypad and enclosure.

CPX9000 Drive



#### CPX9000 Base Drive Type 3R ①

Enclosure Size ②	hp ③	Current (A)	Chassis Frame	Base Catalog Number ④
<b>Low Overload Drive</b>				
7	25	38	FR6	CPX02534AA
	30	46	FR6	CPX03034AA
	40	61	FR6	CPX04034AA
	50	72	FR7	CPX05034AA
	60	87	FR7	CPX06034AA
	75	105	FR7	CPX07534AA
	100	140	FR8	CPX10034AA
	125	170	FR8	CPX12534AA
	150	205	FR8	CPX15034AA
8	200	261	FR9	CPX20034AA
	250	300	FR9	CPX25034AA
<b>High Overload Drive</b>				
7	25	38	FR6	CPX02534DA
	30	46	FR6	CPX03034DA
	40	61	FR7	CPX04034DA
	50	72	FR7	CPX05034DA
	60	87	FR7	CPX06034DA
	75	105	FR8	CPX07534DA
	100	140	FR8	CPX10034DA
	125	170	FR8	CPX12534DA
	8	150	205	FR9
200		245	FR9	CPX20034DA

**Notes**

- ① All Type 3R drives use the Size F enclosure.
- ② See enclosure dimensions beginning on **Page V6-T36-217**.
- ③ hp ratings are provided as a guideline. Drives should be sized per motor nameplate FLA.
- ④ The 18-pulse clean power assembly includes a standard drive, door-mounted local/remote keypad and enclosure.

## 575V Drives

## CPX9000 Drive



## CPX9000 Base Drive Type 1

Enclosure Size <sup>①</sup>	hp <sup>②</sup>	Current (A)	Chassis Frame	Base Catalog Number <sup>③</sup>
<b>Low Overload Drive</b>				
7	25	27	FR6	CPX02515AA
	30	34	FR6	CPX03015AA
	40	41	FR7	CPX04015AA
	50	52	FR7	CPX05015AA
	60	62	FR8	CPX06015AA
	75	80	FR8	CPX07515AA
	100	100	FR8	CPX10015AA
8	125	125	FR9	CPX12515AA
	150	144	FR9	CPX15015AA
	200	208	FR9	CPX20015AA
9	250	261	FR10	CPX25015AA
	300	325	FR10	CPX30015AA
	400	385	FR10	CPX40015AA
10	500	502	FR11	CPX50015AA
	600	590	FR11	CPX60015AA
11	650	650	FR12	CPX65015AA
	700	750	FR12	CPX70015AA
	800	820	FR12	CPX80015AA
<b>High Overload Drive</b>				
7	25	27	FR6	CPX02515DA
	30	34	FR7	CPX03015DA
	40	41	FR7	CPX04015DA
	50	52	FR8	CPX05015DA
	60	62	FR8	CPX06015DA
	75	80	FR8	CPX07515DA
	100	100	FR9	CPX10015DA
8	125	125	FR9	CPX12515DA
	150	144	FR9	CPX15015DA
	200	208	FR10	CPX20015DA
9	250	261	FR10	CPX25015DA
	300	325	FR10	CPX30015DA
	400	385	FR11	CPX40015DA
10	450	460	FR11	CPX45015DA
	500	502	FR11	CPX50015DA
	600	590	FR12	CPX60015DA
11	650	650	FR12	CPX65015DA
	700	750	FR12	CPX70015DA

**Notes**

① See enclosure dimensions beginning on **Page V6-T36-217**.

② hp ratings are provided as a guideline. Drives should be sized per motor nameplate FLA.

③ The 18-pulse clean power assembly includes a standard drive, door-mounted local/remote keypad and enclosure.

CPX9000 Drive



#### CPX9000 Base Drive NEMA 12 Filtered

Enclosure Size <sup>①</sup>	hp <sup>②</sup>	Current (A)	Chassis Frame	Base Catalog Number <sup>③</sup>
<b>Low Overload Drive</b>				
7	25	27	FR6	CPX02565AA
	30	34	FR6	CPX03065AA
	40	41	FR7	CPX04065AA
	50	52	FR7	CPX05065AA
	60	62	FR8	CPX06065AA
	75	80	FR8	CPX07565AA
	100	100	FR8	CPX10065AA
8	125	125	FR9	CPX12565AA
	150	144	FR9	CPX15065AA
	200	208	FR9	CPX20065AA
9	250	261	FR10	CPX25065AA
	300	325	FR10	CPX30065AA
	400	385	FR10	CPX40065AA
10	500	502	FR11	CPX50065AA
	600	590	FR11	CPX60065AA
11	650	650	FR12	CPX65065AA
	700	750	FR12	CPX70065AA
	800	820	FR12	CPX80065AA
<b>High Overload Drive</b>				
7	25	27	FR6	CPX02565DA
	30	34	FR7	CPX03065DA
	40	41	FR7	CPX04065DA
	50	52	FR8	CPX05065DA
	60	62	FR8	CPX06065DA
	75	80	FR8	CPX07565DA
	8	100	100	FR9
125		125	FR9	CPX12565DA
150		144	FR9	CPX15065DA
9	200	208	FR10	CPX20065DA
	250	261	FR10	CPX25065DA
	300	325	FR10	CPX30065DA
10	400	385	FR11	CPX40065DA
	450	460	FR11	CPX45065DA
	500	502	FR11	CPX50065DA
11	600	590	FR12	CPX60065DA
	650	650	FR12	CPX65065DA
	700	750	FR12	CPX70065DA

**Notes**

- ① See enclosure dimensions beginning on **Page V6-T36-217**.
- ② hp ratings are provided as a guideline. Drives should be sized per motor nameplate FLA.
- ③ The 18-pulse clean power assembly includes a standard drive, door-mounted local/remote keypad and enclosure.

## CPX9000 Drive

CPX9000 Base Drive Type 3R<sup>①</sup>

Enclosure Size <sup>②</sup>	hp <sup>③</sup>	Current (A)	Chassis Frame	Base Catalog Number <sup>④</sup>
<b>Low Overload Drive</b>				
7	25	27	FR6	CPX02535AA
	30	34	FR6	CPX03035AA
	40	41	FR7	CPX04035AA
	50	52	FR7	CPX05035AA
	60	62	FR8	CPX06035AA
	75	80	FR8	CPX07535AA
	100	100	FR8	CPX10035AA
8	125	125	FR9	CPX12535AA
	150	144	FR9	CPX15035AA
	200	208	FR9	CPX20035AA
<b>High Overload Drive</b>				
7	25	27	FR6	CPX02535DA
	30	34	FR7	CPX03035DA
	40	41	FR7	CPX04035DA
	50	52	FR8	CPX05035DA
	60	62	FR8	CPX06035DA
	75	80	FR8	CPX07535DA
8	100	100	FR9	CPX10035DA
	125	125	FR9	CPX12535DA
	150	144	FR9	CPX15035DA

**Notes**

- ① All Type 3R drives use the Size F enclosure.
- ② See enclosure dimensions beginning on **Page V6-T36-217**.
- ③ hp ratings are provided as a guideline. Drives should be sized per motor nameplate FLA.
- ④ The 18-pulse clean power assembly includes a standard drive, door-mounted local/remote keypad and enclosure.

#### Options

##### CPX9000 Series Option Board Kits

The CPX9000 Series drives can accommodate a wide selection of expander and adapter option boards to customize the drive for your application needs. The drive's control unit is designed to accept a total of five option boards (see figure below).

The CPX9000 Series factory-installed standard board configuration includes an A9 I/O board and an A2 relay output board, which are installed in slots A and B.

##### 9000X Series Option Board Kits

###### Option Boards

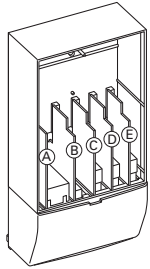

###### Option Board Kits

Option Kit Description <sup>①</sup>	Allowed Slot Locations <sup>②</sup>	Field Installed Catalog Number	Factory Installed Option Designator	SVX Ready Programs						
				Basic	Local/Remote	Standard	MSS	PID	Multi-P.	PFC
<b>Standard I/O Cards</b>										
2 RO (NC/NO)	B	<b>OPTA2</b>	—	■	■	■	■	■	■	■
6 DI, 1 DO, 2 AI, 1AO, 1 +10 Vdc ref, 2 ext +24 Vdc/ext +24 Vdc	A	<b>OPTA9</b>	—	■	■	■	■	■	■	■
<b>Extended I/O Cards</b>										
6 DI	B, C, <b>D</b> , E	<b>OPTB1</b>	<b>B1</b>	—	—	—	—	—	■	■
1 RO (NC/NO), 1 RO (NO), 1 therm	B, C, <b>D</b> , E	<b>OPTB2</b>	<b>B2</b>	—	—	—	—	—	■	■
1 AI (mA isolated), 2 AO (mA isolated)	B, C, <b>D</b> , E	<b>OPTB4</b>	<b>B4</b>	■	■	■	■	■	■	■
3 RO (NO)	B, C, <b>D</b> , E	<b>OPTB5</b>	<b>B5</b>	—	—	—	—	—	■	■
3 Pt100 RTD board	B, C, <b>D</b> , E	<b>OPTB8</b>	<b>B8</b>	—	—	—	—	—	■	—
1 RO (NO), 5 DI 42–240 Vac input	B, C, <b>D</b> , E	<b>OPTB9</b>	<b>B9</b>	—	—	—	—	—	■	■
<b>Communication Cards <sup>③</sup></b>										
Modbus	D, <b>E</b>	<b>OPTC2</b>	<b>C2</b>	■	■	■	■	■	■	■
Modbus TCP	D, <b>E</b>	<b>OPTC1</b>	<b>C1</b>	■	■	■	■	■	■	■
BACnet	D, <b>E</b>	<b>OPTCJ</b>	<b>CJ</b>	■	■	■	■	■	■	■
Ethernet IP	D, <b>E</b>	<b>OPTCK</b>	<b>CK</b>	■	■	■	■	■	■	■
Johnson Controls N2	D, <b>E</b>	<b>OPTC2</b>	<b>CA</b>	■	■	■	■	■	■	■
PROFIBUS DP	D, <b>E</b>	<b>OPTC3</b>	<b>C3</b>	■	■	■	■	■	■	■
LonWorks	D, <b>E</b>	<b>OPTC4</b>	<b>C4</b>	■	■	■	■	■	■	■
PROFIBUS DP (D9 connector)	D, <b>E</b>	<b>OPTC5</b>	<b>C5</b>	■	■	■	■	■	■	■
CANopen (slave)	D, <b>E</b>	<b>OPTC6</b>	<b>C6</b>	■	■	■	■	■	■	■
DeviceNet	D, <b>E</b>	<b>OPTC7</b>	<b>C7</b>	■	■	■	■	■	■	■
Modbus (D9 type connector)	D, <b>E</b>	<b>OPTC8</b>	<b>C8</b>	■	■	■	■	■	■	■
RS-232 with D9 connection	D, <b>E</b>	<b>OPTD3</b>	<b>D3</b>	■	■	■	■	■	■	■

###### Notes

- ① AI = Analog Input; AO = Analog Output, DI = Digital Input, DO = Digital Output, RO = Relay Output
- ② Option card must be installed in one of the slots listed for that card. Slot indicated in bold is the preferred location.
- ③ OPTC2 is a multi-protocol option card.



**Modbus RTU Network Communications**

The Modbus Network Card OPTC2 is used for connecting the 9000X Drive as a slave on a Modbus network. The interface is connected by a 9-pin DSUB connector (female) and the baud rate ranges from 300 to 19,200 baud. Other communication parameters include an address range from 1 to 247; a parity of None, Odd or Even; and the stop bit is 1.

**PROFIBUS Network Communications**

The PROFIBUS Network Card OPTC3 is used for connecting the 9000X Drive as a slave on a PROFIBUS-DP network. The interface is connected by a 9-pin DSUB connector (female). The baud rates range from 9.6K baud to 12M baud, and the addresses range from 1 to 127.

**LonWorks Network Communications**

The LonWorks Network Card OPTC4 is used for connecting the 9000X Drive on a LonWorks network. This interface uses Standard Network Variable Types (SNVT) as data types. The channel connection is achieved using a FTT-10A Free Topology transceiver via a single twisted transfer cable. The communication speed with LonWorks is 78 kBits/s.

**CANopen (Slave) Communications**

The CANopen (Slave) Network Card OPTC6 is used for connecting the 9000X Drive to a host system. According to ISO® 11898 standard cables to be chosen for CAN bus should have a nominal impedance of 120 ohms, and specific line delay of nominal 5 nS/m. 120 ohm line termination resistors required for installation.

**DeviceNet Network Communications**

The DeviceNet Network Card OPTC7 is used for connecting the 9000X Drive on a DeviceNet Network. It includes a 5.08 mm pluggable connector. Transfer method is via CAN using a two-wire twisted shielded cable with two-wire bus power cable and drain. The baud rates used for communication include 125K baud, 250K baud and 500K baud.

**Johnson Controls Metasys N2 Network Communications**

The OPTC2 fieldbus board provides communication between the 9000X Drive and a Johnson Controls Metasys™ N2 network. With this connection, the drive can be controlled, monitored and programmed from the Metasys system. The N2 fieldbus is available as a factory-installed option and as a field-installable kit.

**Modbus/TCP Network Communications**

The Modbus/TCP Network Card OPTCI is used for connecting the 9000X Drive to Ethernet networks using Modbus protocol. It includes an RJ-45 pluggable connector. This interface provides a selection of standard and custom register values to communicate drive parameters. The board supports 10 Mbps and 100 Mbps communication speeds. The IP address of the board is configurable over Ethernet using a supplied software tool.

**BACnet Network Communications**

The BACnet Network Card OPTCJ is used for connecting the 9000X Drive to BACnet networks. It includes a 5.08 mm pluggable connector. Data transfer is Master-Slave/Token Passing (MS/TP) RS-485. This interface uses a collection of 30 Binary Value Objects (BVOs) and 35 Analog Value Objects (AVOs) to communicate drive parameters. The card supports 9.6, 19.2 and 38.4 Kbaud communication speeds and supports network addresses 1 to 127.

**Ethernet/IP Network Communications**

The Ethernet/IP Network Card OPTCK is used for connecting the 9000X Drive to Ethernet/Industrial Protocol networks. It includes an RJ-45 pluggable connector. The interface uses CIP objects to communicate drive parameters (CIP is "Common Industrial Protocol," the same protocol used by DeviceNet). The board supports 10 Mbps and 100 Mbps communication speeds. The IP address of the board is configurable by Static, BOOTP and DHCP methods.

## Control/Communication Option Descriptions

For availability, see Product Selection for base drive voltage required.

## Available Control/Communications Options

Option	Description	Option Type
K1	<b>Door-Mounted Speed Potentiometer</b> —Provides the CPX9000 with the ability to adjust the frequency reference using a door-mounted potentiometer. This option uses the 10 Vdc reference to generate a 0–10V signal at the analog voltage input signal terminal. When the HOA bypass option is added, the speed is controlled when the HOA switch is in the HAND position. Without the HOA bypass option, a two-position switch (labeled local/remote) is provided on the keypad to select speed reference from the speed potentiometer or a remote speed signal.	Control
K2	<b>Door-Mounted Speed Potentiometer with HOA Selector Switch</b> —Provides the CPX9000 with the ability to start/stop and adjust the speed reference from door-mounted control devices or remotely from customer-supplied inputs. In HAND position, the drive will start and the speed is controlled by the door-mounted speed potentiometer. The drive will be disabled in the OFF position. When AUTO is selected, the drive run and speed control commands are via user-supplied dry contact and 4–20 mA signal.	Control
K3	<b>3–15 psig Follower</b> —Provides a pneumatic transducer that converts a 3–15 psig pneumatic signal to either 0–8 Vdc or a 1–9 Vdc signal interface with the CPX9000. The circuit board is mounted on the inside of the front enclosure panel and connects to the user's pneumatic control system via 6 ft (1.8m) of flexible tubing and a 1/4 inch (6.4 mm) brass tube union.	Control
K4	<b>HAND/OFF/AUTO Switch for Non-Bypass Configurations</b> —Provides a three-position selector switch that allows the user to select either a HAND or AUTO mode of operation. HAND mode is defaulted to keypad operation, and AUTO mode is defaulted to control from an external terminal source. These modes of operation can be configured via drive programming to allow for alternate combinations of start and speed sources. Start and speed sources include Keypad, I/O and fieldbus.	Control
K5	<b>MANUAL/AUTO Speed Reference Switch</b> —Provides door-mounted selector switch for MANUAL/AUTO speed reference.	Control
K6	<b>START/STOP Pushbuttons</b> —Provide door-mounted START and STOP pushbuttons for either bypass or non-bypass configurations.	Control
KF	<b>Bypass Test Switch for RB and RA</b> —Allows the user to energize the AF drive for testing while operating the motor on the bypass controller. The Test Switch is mounted on the inside of the enclosure door.	Addl. bypass
K0	<b>Standard Elapsed Time Meter</b> —Provides a door-mounted elapsed run-time meter.	Control
L1	<b>Power On and Fault Power Lights</b> —Provide a white Power On light that indicates power to the enclosed cabinet and a red fault light that indicates a drive fault has occurred.	Light
L2	<b>Bypass Pilot Lights for RB, RA Bypass Options</b> —A green light indicates when the motor is running in Inverter mode and an amber light indicates when the motor is running in Bypass mode. The lights are mounted on the enclosure door, above the switches.	Addl. bypass
LE	<b>Red Run Pilot Light 0.87-Inch (22 mm)</b> —Provides a red Run pilot light that indicates the drive is running.	Light
P1	<b>Input Circuit Breaker</b> —High interrupting circuit breaker that provides a means of short-circuit protection for the power cables between it and the CPX9000, and protection from high-level ground faults on the power cable. Allows a convenient means of disconnecting the CPX9000 from the line and the operating mechanism can be padlocked in the OFF position. This is factory mounted in the enclosure. Standard rating is 65 kAIC at 208/480V. 100 kAIC is available as an option.	Input
PE	<b>Output Contactor</b> —Provides a means for positive disconnection of the drive output from the motor terminals. The contactor coil is controlled by the drive's run or permissive logic. NC and NO auxiliary contacts rated at 10A, 600 Vac are provided for customer use. Bypass options <b>RB</b> and <b>RA</b> include an output contactor as standard. This option includes a low VA 115 Vac fused control power transformer and is factory mounted in the enclosure.	Output
PF	<b>Output Filter</b> —Used to reduce the transient voltage (DV/DT) at the motor terminals. The output filter is recommended for cable lengths exceeding 100 ft (30.5m) with a drive of 3 hp and above, for cable lengths of 33 ft (10.1m) with a drive of 2 hp and below, or for a drive rated at 525–690V. This option is mounted in the enclosure.	Output
PG	<b>MotoRx (300–600 Ft) 1000 V/μS DV/DT Filter</b> —Used to reduce transient voltage (DV/DT) and peak voltages at the motor terminals. This option is comprised of a 0.5% line reactor, followed by capacitive filtering and an energy recovery/clamping circuit. Unlike the output filter (see option <b>PF</b> ), the MotoRx recovers most of the energy from the voltage peaks, resulting in a lower voltage drop to the motor, and therefore conserving power. This option is used when the distance between a single motor and the drive is 300–600 ft (91.4–182.9m).	Output
PH	<b>Single Overload Relay</b> —Uses a bimetallic overload relay to provide additional overload current protection to the motor on configurations without bypass options. It is included with the bypass configurations for overload current protection in the bypass mode. The overload relay is mounted within the enclosure, and is manually resettable. Heater pack included.	Output
PI	<b>Dual Overload Relays</b> —This option is recommended when a single drive is operating two motors and overload current protection is needed for each of the motors. The standard configuration includes two bimetallic overload relays, each sized to protect a motor with 50% of the drive hp rating. For example, a 100 hp drive would include two overload relays sized to protect two 50 hp motors. The relays are mounted within the enclosure, and are manually resettable. Heater packs not included.	Output
PN	<b>Dual Overloads for Bypass</b> —This option is recommended when a single drive is operating two motors in the Bypass mode and overload current protection is needed for each of the motors. The standard configuration includes two bimetallic overload relays, each sized to protect a motor with 50% of the drive hp rating. For example, a 100 hp drive would include two overload relays sized to protect two 50 hp motors. The relays are mounted within the enclosure, and are manually resettable.	Addl. bypass

For availability, see Product Selection for base drive voltage required.

### Available Control/Communications Options, continued

Option	Description	Option Type
RA	<b>Manual HOA Bypass Controller</b> —The manual HAND/OFF/AUTO (HOA)—three-contactor—bypass option provides a means of bypassing the CPX9000, allowing the AC motor to be operated at full speed directly from the AC supply line. This option consists of an input HMCP, a fused control power transformer, and a full voltage bypass starter with a door-mounted HOA selector switch and an INVERTER/BYPASS switch. The HOA switch provides the ability to start and stop the drive in the inverter mode. IEC type input, bypass and input contactors are provided. The contactors are mechanically and electrically interlocked (see wiring diagram on <a href="#">Page V6-T36-216</a> ).	Bypass
RB	<b>Manual IOB Bypass Controller</b> —The manual INVERTER/OFF/BYPASS (IOB)—three-contactor—bypass option provides a means of bypassing the CPX9000, allowing the AC motor to be operated at full speed directly from the AC supply line. This option consists of an input HMCP, a fused control power transformer, and a full voltage bypass starter with a door-mounted IOB selector switch. IEC type input, bypass and input contactors are provided. The contactors are mechanically and electrically interlocked (see wiring diagram on <a href="#">Page V6-T36-216</a> ).	Bypass
RC	<b>Auto Transfer HOA Bypass Controller</b> —The manual HAND/OFF/AUTO (HOA)—three-contactor—bypass option provides a means of bypassing the CPX9000, allowing the AC motor to be operated at full speed directly from the AC supply line. The circuitry provides an automatic transfer of the load to “across the line” operation after a drive trip. This option consists of an input HMCP, a fused control power transformer, and a full voltage bypass starter with a door-mounted HOA selector switch and an INVERTER/BYPASS switch. The HOA switch provides the ability to start and stop the drive in either mode. IEC type input, bypass and input contactors are provided. The contactors are mechanically and electrically interlocked (see wiring diagram on <a href="#">Page V6-T36-216</a> ). Door-mounted pilot lights are provided that indicate bypass or inverter operation. A green light indicates when the motor is running in inverter mode and an amber light indicates when the motor is running in bypass mode. <b>WARNING:</b> The motor may restart when the overcurrent relay is reset when operating in bypass, unless the IOB selector switch is turned to the OFF position.	Bypass
RD	<b>Auto Transfer IOB Bypass Controller</b> —The auto INVERTER/OFF/BYPASS (IOB)—three-contactor—bypass option provides a means of bypassing the CPX9000, allowing the AC motor to be operated at full speed directly from the AC supply line. The circuitry provides an automatic transfer of the load to “across the line” operation after a drive trip. This option consists of an input HMCP, a fused control power transformer, and a full voltage bypass starter with a door-mounted IOB selector switch. IEC type input, bypass and input contactors are provided. The contactors are mechanically and electrically interlocked (see wiring diagram on <a href="#">Page V6-T36-216</a> ). Door-mounted pilot lights are provided that indicate bypass or inverter operation. A green light indicates when the motor is running in inverter mode and an amber light indicates when the motor is running in bypass mode. <b>WARNING:</b> The motor may restart when the overcurrent relay is reset when operating in bypass, unless the IOB selector switch is turned to the OFF position.	Bypass
RG	<b>Reduced Voltage Starter for Bypass</b> —Used in conjunction with bypass option RA, RB, RC or RD. This option adds reduced voltage soft starter to bypass assembly for soft starting in bypass mode.	Bypass
S7	<b>10.00-Inch (254.0 mm) Expansion</b> —Expansion cabinet allows for special components, customer-supplied components or oversized cables. <b>NOTE:</b> Enclosure expansion rated Type 1 only.	Enclosure
S8	<b>20.00-Inch (508.0 mm) Expansion</b> —Expansion cabinet allows for special components, customer-supplied components or oversized cables. <b>NOTE:</b> Enclosure expansion rated Type 1 only.	Enclosure
S9	<b>Space Heater</b> —Prevents condensation from forming in the enclosure when the drive is inactive or in storage. Includes a thermostat for variable temperature control. The heater requires a customer-supplied 115V remote supply source.	Enclosure

### Dissipated Watt Losses

Horsepower	40	50	60	75	100	125	150	200	250	300	350	400	450	500	600	700	800
Watts	1844	2170	2540	3040	4011	4940	5730	8020	9383	11600	13600	15700	16250	17976	20393	27200	31400

### Conformal (Varnished) Coating <sup>①</sup>

Chassis Frame	Delivery Code	Chassis Frame	Delivery Code
FR6	FP	FR9	FP
FR7	FP	FR10	FP
FR8	FP	FR11	FP
—	—	FR12	FP

### 480V Input Disconnect Selection <sup>②</sup>

Horsepower	P1 Input Breaker	Bypass Motor Circuit Protector (RA, RB, RC, RD)
25	HFD3050	HMCP050K2C
30	HFD3060	HMCP100R3C
40	HFD3080	HMCP100R3C
50	HFD3100	HMCP100R3C
60	HFD3100	HMCP150T4C
75	HFD3125	HMCP150T4C
100	HFD3150	HMCP150U4C
125	HFD3200	HMCP250W5C
150	HFD3225	HMCP250W5C
200	HKD3300	HMCP400X5C
250	HKD3400	HMCP400X5C
300–400	HLD3600	HMCP600L6W
500–600	HND3800	HMCP800X7W
650–800	HND312	<sup>③</sup>

#### Notes

- <sup>①</sup> See catalog number description to order.
- <sup>②</sup> Contact factory for 208V and 575V applications.
- <sup>③</sup> Contact factory.

## Enclosed Drive Options

36

## Light Options

Description	Catalog Number Suffix
Power on, run, fault LED lights (22 mm)	L1
Power on, fault LED lights (22 mm)	L3
Green LED run light (22 mm)	LA
Green LED stop light (22 mm)	LD
Red LED run light (22 mm)	LE
Red LED stop light (22 mm)	LF
Red LED fault light (22 mm)	LG
Power on white LED light (22 mm)	LJ
Miscellaneous LED light (22 mm)	LU

## Control Options

Description	Catalog Number Suffix
Door-mounted speed potentiometer	K1
Door-mounted speed potentiometer with HOA selector switch	K2
3–15 psig follower	K3
HOA selector switch	K4
MANUAL/AUTO reference switch	K5
START-STOP pushbuttons	K6
Type D2 control relay	SD
On-delay relay	SE
Off-delay relay	SF
Additional terminal blocks per 4 points	SD

## Bypass Control Options

Description	Catalog Number Suffix
Bypass test switch used with RA and RB	KF
Inverter/bypass pilot lights	L2

## Meter Options

Description	Catalog Number Suffix
Standard elapsed time meter	KO
Frequency meter	KS
MP-3000 relay with URTD	KV
MP-3000 relay with URTD and CTs	KU

## Enclosure Options

Enclosure Size	Catalog Number Suffix
<b>10.00 Inch (254.0 mm) Expansion</b>	
7	S7
8	S7
9	S7
10	S7
11	S7
<b>20.00 Inch (508.0 mm) Expansion</b>	
7	S8
8	S8
9	S8
10	S8
11	S8
<b>Space Heater <sup>①</sup></b>	
7	S9
8	S9
9	S9
10	S9
11	S9
<b>Plastic Nameplate</b>	
7	SN
8	SN
9	SN
10	SN
11	SN

**Note**

<sup>①</sup> Requires customer-supplied 115 Vac supply.

**208V and 230V Power Options, 25–200 hp**

Description	Catalog Number Suffix
Input breaker	<b>P1</b>
Output contactor	<b>PE</b>
Single overload relay	<b>PH</b>
Dual overload relays	<b>PI</b>
MOV	<b>P7</b>
50 kA surge protective device	<b>P8</b>
100 kA surge protective device	<b>P9</b>

**480 and 575V Power Options, 25–800 hp**

Description	Catalog Number Suffix
Input breaker	<b>P1</b>
Output contactor	<b>PE</b>
Output filter	<b>PF</b>
MotoRx (300–600 Ft) DV/DT filter	<b>PG</b>
Single overload relay	<b>PH</b>
Dual overload relays	<b>PI</b>
Input MOV	<b>P7</b>
50 kA surge protective device	<b>P8</b>
100 kA surge protective device	<b>P8</b>

**208V and 230V Bypass Options, 25–200 hp**

Description	Catalog Number Suffix
Manual HOA bypass controller	<b>RA</b>
IOB bypass controller	<b>RB</b>
Auto transfer HOA bypass controller	<b>RC</b>
Auto transfer IOB bypass controller	<b>RD</b>
Reduced voltage starter for bypass	<b>RG</b>
Dual overloads for bypass	<b>PN</b>

**480 and 575V Bypass Options, 25–800 hp**

Description	Catalog Number Suffix
Manual HOA bypass controller	<b>RA</b>
IOB bypass controller	<b>RB</b>
Auto transfer HOA bypass controller	<b>RC</b>
Auto transfer IOB bypass controller	<b>RD</b>
Reduced voltage starter for bypass	<b>RG</b>
Dual overloads for bypass	<b>PN</b>

## Technical Data and Specifications

### CPX9000 Drives

Description	Specification
<b>Primary Design Features</b>	
45–66 Hz input frequency	Standard
Output: AC volts maximum	Input voltage base
Output frequency range	0–320 Hz
Initial output current ( $I_H$ )	250% for 2 seconds
Overload (1 minute [ $I_H/I_L$ ])	150%/110%
Enclosure space heater	Optional
Oversize enclosure	Standard
Output contactor	Optional
Bypass motor starter	Optional
Listings	UL, cUL, 508C
<b>Protection Features</b>	
Incoming line fuses	Standard 200 kAIC rating
AC input circuit disconnect	Optional
Phase rotation insensitive	Standard
EMI filter	Standard FR6 thru FR9 <sup>①</sup>
Input phase loss protection	Standard
Input overvoltage protection	Standard
Line surge protection	Standard
Output short-circuit protection	Standard
Output ground fault protection	Standard
Output phase protection	Standard
Overtemperature protection	Standard
DC overvoltage protection	Standard
Drive overload protection	Standard
Motor overload protection	Standard
Programmer software	Optional
Local/remote keypad	Standard
Keypad lockout	Standard
Fault alarm output	Standard
Built-in diagnostics	Standard
Surge protective device	Optional

Description	Specification
<b>Input/Output Interface Features</b>	
Setup adjustment provisions	
Remote keypad/display	Standard
Personal computer	Standard
Operator control provisions	
Drive mounted keypad/display	Standard
Remote keypad/display	Standard
Conventional control elements	Standard
Serial communications	Optional
115 Vac control circuit	Optional
Speed setting inputs	
Keypad	Standard
0–10 Vdc potentiometer/voltage signal	Standard
4–20 mA isolated	Configurable
4–20 mA differential	Configurable
3–15 psig	Optional
Analog outputs	
Speed/frequency	Standard
Torque/load/current	Programmable
Motor voltage	Programmable
Kilowatts	Programmable
0–10 Vdc signals	Configurable w/jumpers
4–20 mA DC signals	Standard
Isolated signals	Standard
Discrete outputs	
Fault alarm	Standard
Drive running	Standard
Drive at set speed	Programmable
Optional parameters	14
Dry contacts	2 Form C contacts available
Additional discrete outputs	Optional
<b>Communications</b>	
RS-232	Standard
RS-422/485	Optional
DeviceNet™	Optional
Modbus RTU	Optional
CanOpen (slave)	Optional
Profibus-DP	Optional
LonWorks	Optional
Johnson Controls Metasys N2	Optional
Ethernet IP/Modbus TCP	Optional
BACnet	Optional

#### Note

<sup>①</sup> The EMI filter is optional in FR10 and larger.

## CPX9000 Drives

Description	Specification
<b>Performance Features</b>	
Sensorless vector control	Standard
Volts/hertz control	Standard
IR and slip compensation	Standard
Electronic reversing	Standard
Dynamic braking	Optional
DC braking	Standard
PID set point controller	Programmable
Critical speed lockout	Standard
Current (torque) limit	Standard
Adjustable acceleration/deceleration	Standard
Linear or S curve accel/decel	Standard
Jog at preset speed	Standard
Thread/preset speeds	7
Automatic restart	Selectable
Coasting motor start	Standard
Coast or ramp stop selection	Standard
Elapsed time meter	Optional
Carrier frequency adjustment	1–16 kHz
<b>Standard Conditions for Application and Service</b>	
Maximum operating ambient temperature	0–50°C up to FR9 0–40°C FR10 and larger, consult factory for 50°C rating above FR9
Storage temperature	–40 to 60°C
Humidity (maximum), noncondensing	95%
Altitude (maximum without derate)	3300 ft (1000m)
Line voltage variation	+10/–15%
Line frequency variation	45–66 Hz
Efficiency	>95%
Power factor (displacement)	0.99+
Power factor (apparent)	0.99

## Standard I/O Specifications

Description	Specification
Six–digital input programmable	24V: "0" $\leq 10V$ , "1" $\geq 18V$ , $R_i > 5$ kohms
Two–analog input configurable w/jumpers	Voltage: 0– $\pm 10V$ , $R_i > 200$ kohms Current: 0 (4)–20 mA, $R_i = 250$ ohms
Two–digital output programmable	Form C relays 250 Vac 30 Vdc 2 amp resistive
One–analog output programmable configurable w/jumper	0–20 mA, $R_L$ max. 500 ohms 10 bits $\pm 2\%$

## I/O Specifications for Control/Communication Options

Description	Specification
Analog voltage, input	0– $\pm 10V$ , $R_i \geq 200$ kilohms
Analog current, input	0 (4)–20 mA, $R_i = 250$ ohms
Digital input	24V: "0" $\leq 10V$ , "1" $\geq 18V$ , $R_i > 5$ kilohms
Auxiliary voltage	24V ( $\pm 20\%$ ), max. 50 mA
Reference voltage	10V $\pm 3\%$ , max. 10 mA
Analog current, output	0 (4)–20 mA, $R_L = 500$ kilohms, resolution 10 bit, accuracy $\leq \pm 2\%$
Analog voltage, output	0 (2)–10V, $R_L \geq 1$ kilohm, resolution 10 bit, accuracy $\leq \pm 2\%$
Relay output max. switching voltage	300 Vdc, 250 Vac
Relay output max. switching load	3A/24 Vdc, 300 Vdc, 250 Vac <sup>①</sup>
Relay output max. continuous load	2A rms
Thermistor input	$R_{trip} = 4.7$ kohms

**Note**

<sup>①</sup> For applications above 3A consult instruction manual.

#### Wiring Diagrams

36

Power Diagram Up to FR9

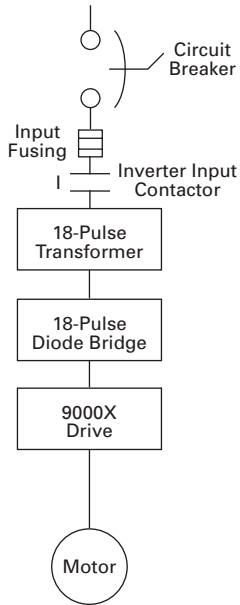

Power Diagram Up to FR9 with Bypass

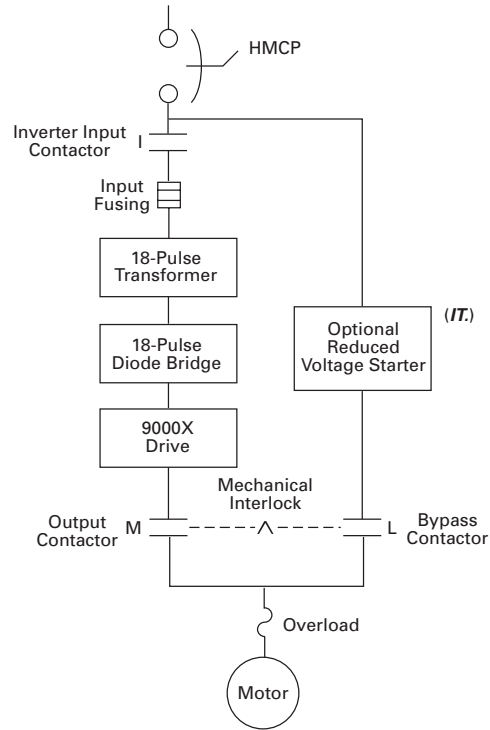

Power Diagram FR10 and Larger

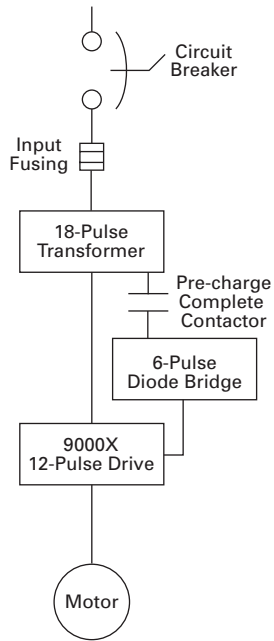

Power Diagram FR10 and Larger with Bypass

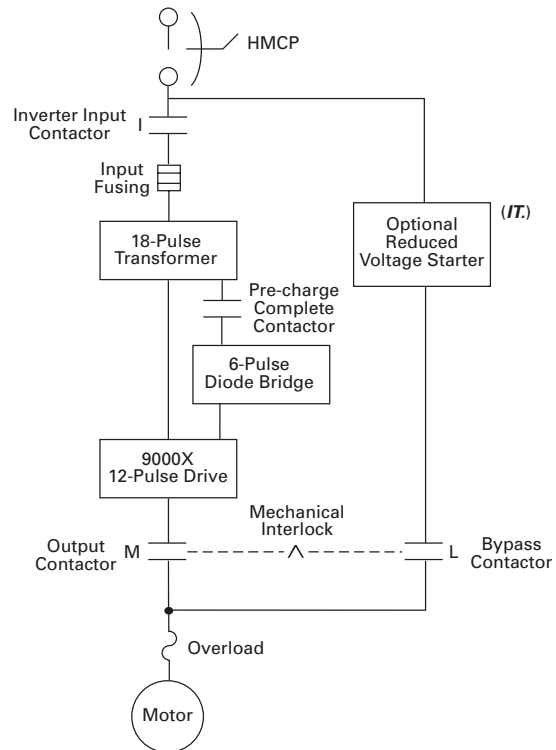



## Dimensions

Approximate Dimensions in Inches (mm)

### Enclosure Size 7

25–150 hp  $I_L$  and 25–125 hp  $I_H$  480V—25–100 hp  $I_L$  and 25–75 hp  $I_H$  575V

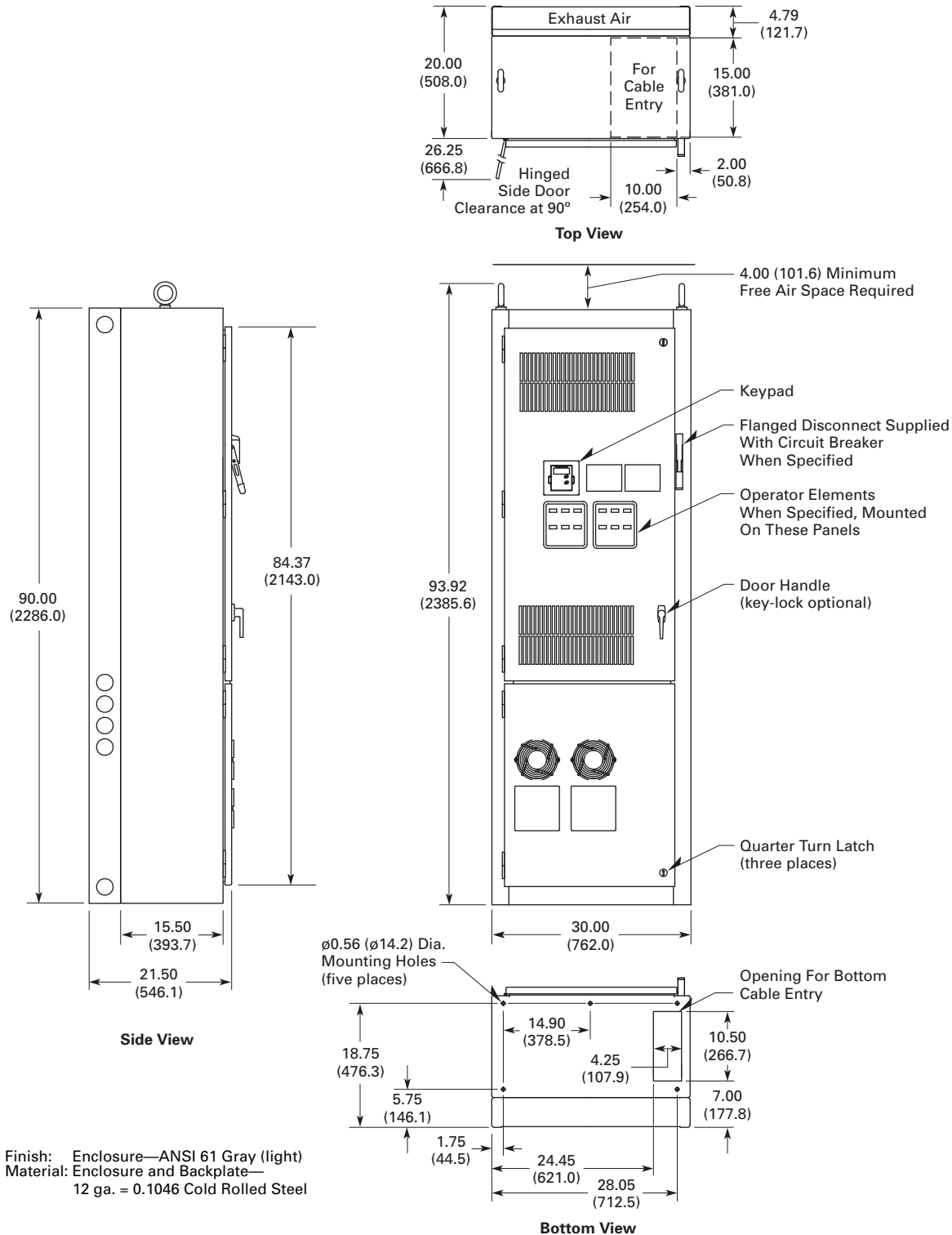

# 36.7

## Adjustable Frequency Drives

CPX9000 Drives

Approximate Dimensions in Inches (mm)

### Enclosure Size 8

200–250 hp I<sub>L</sub> and 150–200 hp I<sub>H</sub> 480V—125–200 hp I<sub>L</sub> and 100–150 hp I<sub>H</sub> 575V

36

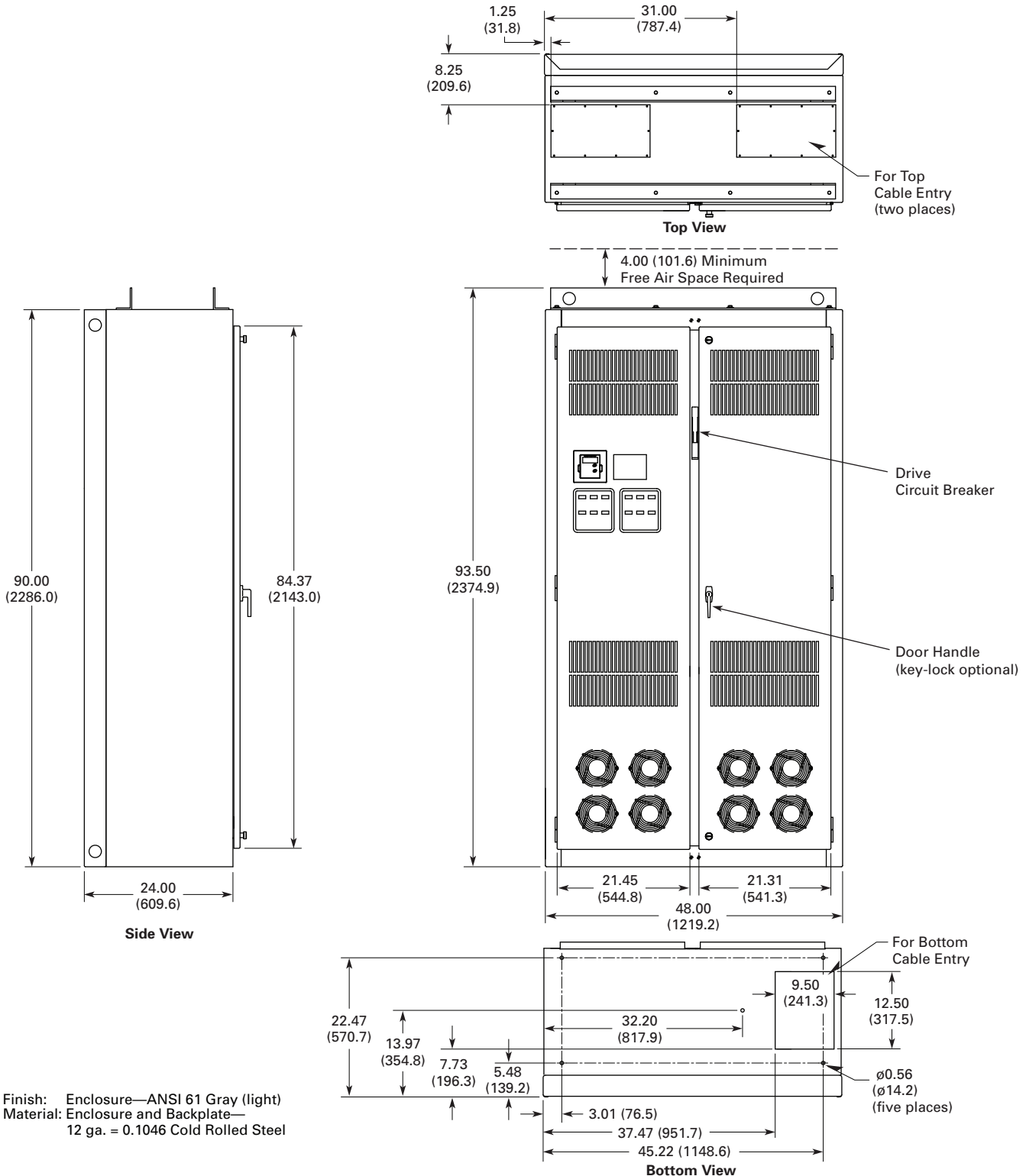

Approximate Dimensions in Inches (mm)

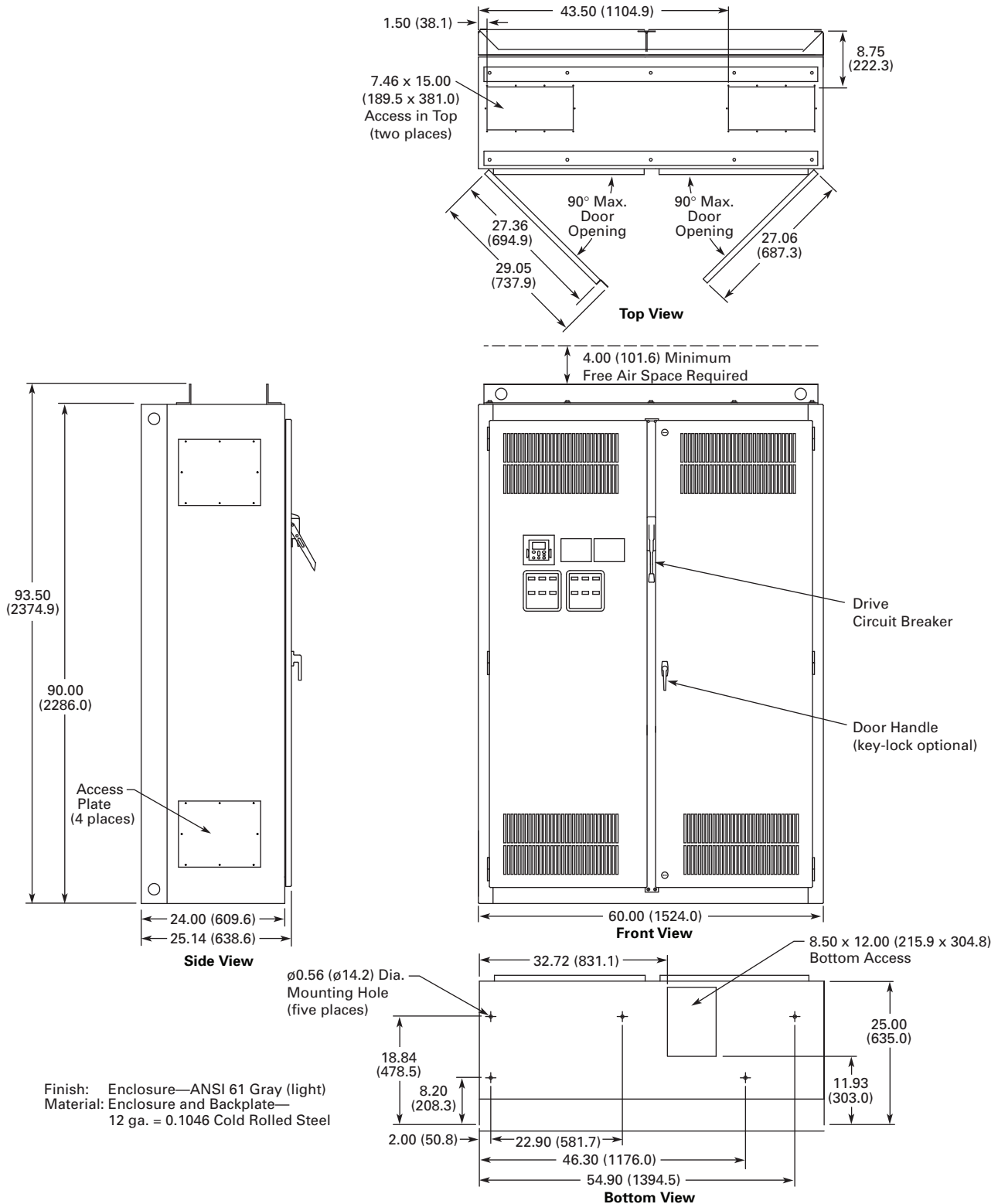
**Enclosure Size 9****300–400 hp I<sub>L</sub> and 250–350 hp I<sub>H</sub> 480V—250–400 hp I<sub>L</sub> and 200–300 hp I<sub>H</sub> 575V**

# 36.7

## Adjustable Frequency Drives

CPX9000 Drives

Approximate Dimensions in Inches (mm)

### Enclosure Size 10

500–600 hp I<sub>L</sub> and 400–500 hp I<sub>H</sub> 480V—500–600 hp I<sub>L</sub> and 400–500 hp I<sub>H</sub> 575V

36

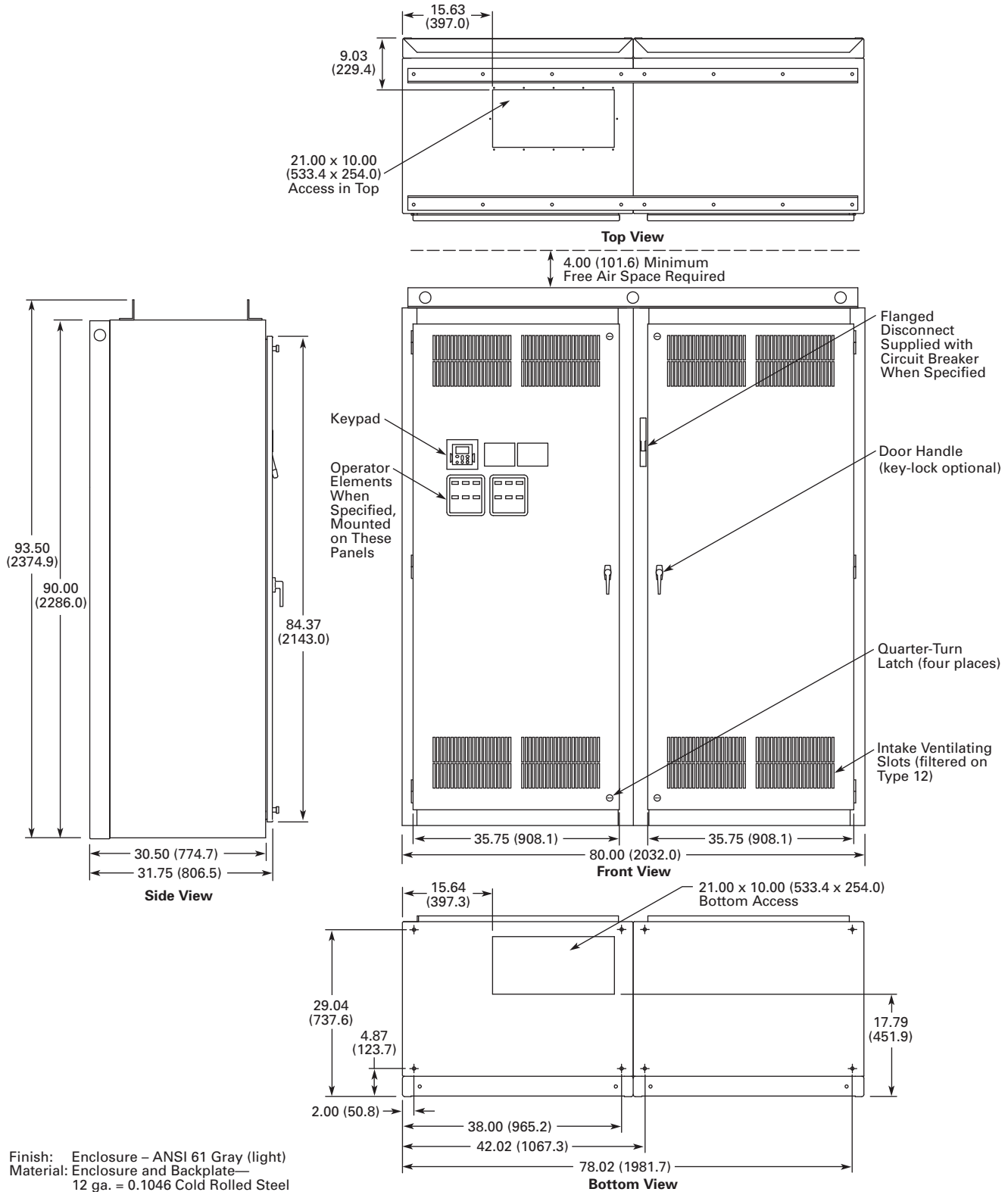

Approximate Dimensions in Inches (mm)

### Enclosure Size F Type 3R Drives

25–250 hp I<sub>L</sub> and 25–200 hp I<sub>H</sub> 480V—25–200 hp I<sub>L</sub> and 25–150 hp I<sub>H</sub> 575V Type 3R Drives

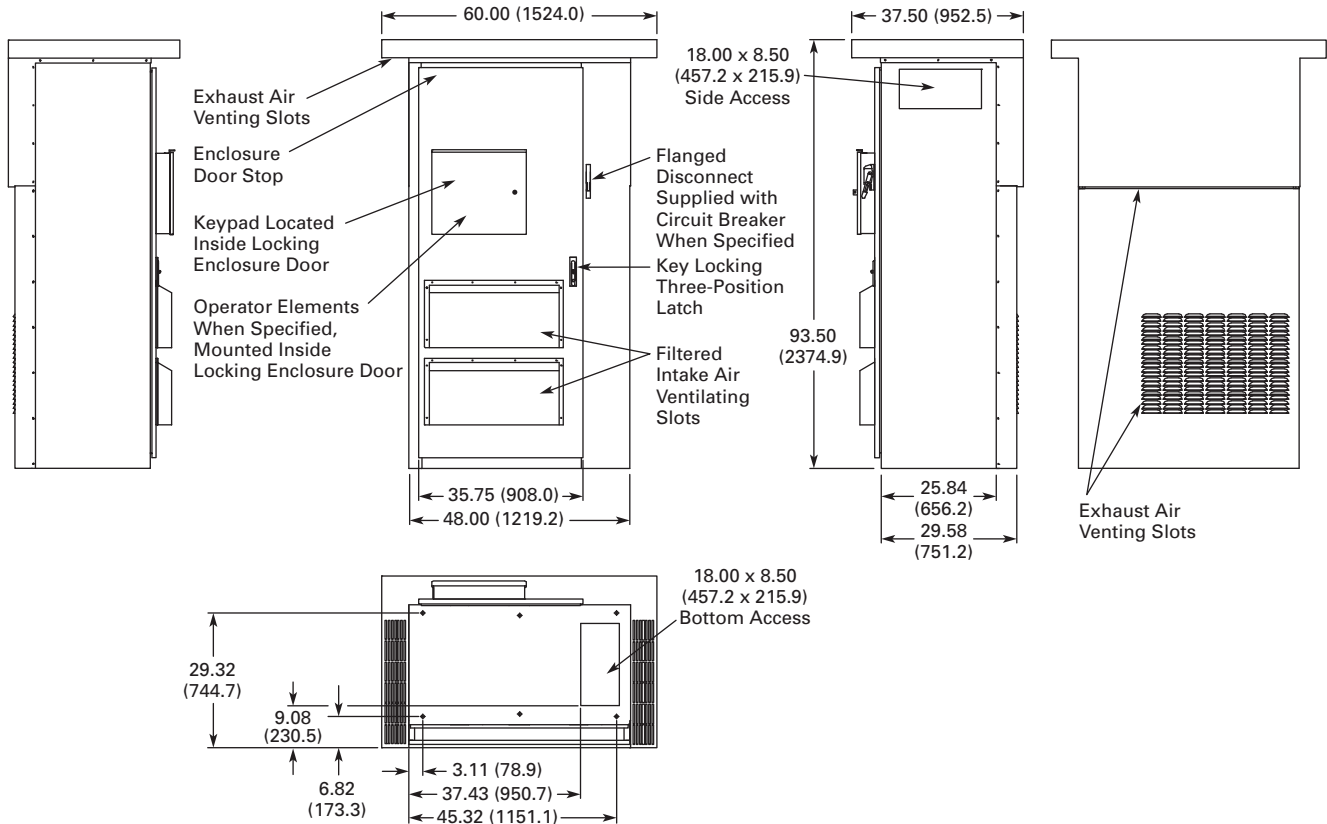

### CPX9000 Enclosure Dimensions

Enclosure Size <sup>①</sup>	Width	Height	Depth	Approx. Shipping Weight in Lbs (kg)
7	30.00 (762.0)	90.00 (2286.0)	21.50 (546.1)	1000 (454)
8	48.00 (1219.2)	90.00 (2286.0)	26.14 (664.0)	1400 (636)
9	60.00 (1524.0)	90.00 (2286.0)	25.74 (653.8)	1800 (817)
10	80.00 (2032.0)	90.00 (2286.0)	31.75 (806.5)	2100 (953)
11 <sup>②③</sup>	120.00 (3048.0)	90.00 (2286.0)	25.74 (653.8)	2500 (1,135)
F <sup>④</sup>	60.00 (1524.0)	93.50 (2374.9)	37.50 (952.5)	2500 (1,135)

#### Notes

- ① Enclosure sizes accommodate drive and options, including bypass and disconnect. For other power options, consult your Eaton representative.
- ② Consult factory. Limited power options available.
- ③ Enclosure size 11 consists of two of the enclosure size 9.
- ④ All Type 3R drives use the Size F enclosure.

#### LCX9000 Liquid Cooled Adjustable Frequency Drives

36



#### Product Description

The LCX9000 Liquid Cooled Drive family continues Eaton's tradition of providing state-of-the-industry products, by taking advantage of liquid cooling technology in lieu of air-cooling techniques.

The LCX9000 drives are liquid-cooled products that utilize potable water or a water-glycol mixture as a cooling medium.

#### Features and Benefits

- Compact size and low heat transfer rates allow enclosure size to be greatly reduced, which is especially beneficial in UL Type 4X applications
- Design is modular, with control and power modules independent of each other. Connection between power and control modules can be direct or extended via a fiber optic cable
- Same reliable control module and operating system as the SPX9000 air-cooled drives
- CE mark ensures compliance with the Electromagnetic Compatibility Directive (EMC) and the Low Voltage Directive (LVD)
- Reliable drive with over 500,000 hours MTBF based on MIL 217
- Currently supports DeviceNet, PROFIBUS-DP, Modbus RTU and Modbus TCP communication protocols
- Separately mounted line reactor included with AC fed models

#### Contents

<i>Description</i>	<i>Page</i>
LCX9000 Drives	
Catalog Number Selection . . . . .	<b>V6-T36-223</b>
Product Selection . . . . .	<b>V6-T36-224</b>
Options . . . . .	<b>V6-T36-227</b>
Technical Data and Specifications . . . . .	<b>V6-T36-229</b>
Wiring Diagrams . . . . .	<b>V6-T36-230</b>
Dimensions . . . . .	<b>V6-T36-232</b>

#### Standards and Certifications

- CE



## Catalog Number Selection

## LCX9000 Liquid Cooled Adjustable Frequency Drives

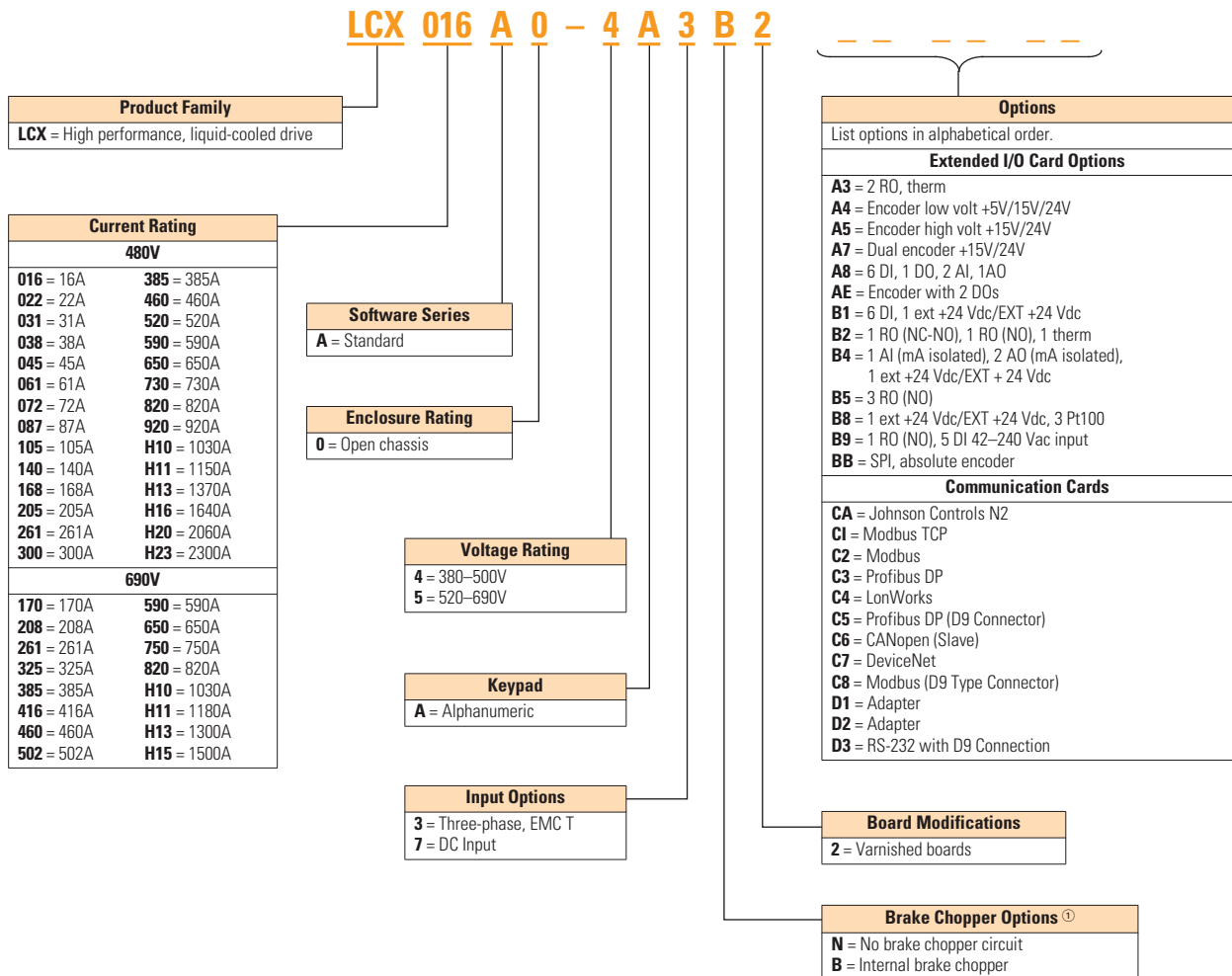
**Note**

<sup>①</sup> Brake chopper is only available in 480V CH3 drives.

## Product Selection

36

## LCX9000 Liquid Cooled Drives



## 380–500 Vac Liquid Cooled Drives

## Motor Output

## Current

Thermal, $I_{th}$ (A)	$I_L$ (A)	$I_H$ (A)	kW	Chassis	Catalog Number
16	15	11	7.5	CH3	LCX016A0-4A3N2
22	20	15	11	CH3	LCX022A0-4A3N2
31	28	21	15	CH3	LCX031A0-4A3N2
38	35	25	18.5	CH3	LCX038A0-4A3N2
45	41	30	22	CH3	LCX045A0-4A3N2
61	55	41	30	CH3	LCX061A0-4A3N2
72	65	48	37	CH4	LCX072A0-4A3N2
87	79	58	45	CH4	LCX087A0-4A3N2
105	95	70	55	CH4	LCX105A0-4A3N2
140	127	93	75	CH4	LCX140A0-4A3N2
168	153	112	90	CH5	LCX168A0-4A3N2
205	186	137	110	CH5	LCX205A0-4A3N2
261	237	174	132	CH5	LCX261A0-4A3N2
300	273	200	160	CH61	LCX300A0-4A3N2
385	350	257	200	CH61	LCX385A0-4A3N2
460	418	307	250	CH72	LCX460A0-4A3N2
520	473	347	250	CH72	LCX520A0-4A3N2
590	536	393	315	CH72	LCX590A0-4A3N2
650	591	433	355	CH72	LCX650A0-4A3N2
730	664	487	400	CH72	LCX730A0-4A3N2
820	745	547	450	CH63	LCX820A0-4A3N2
920	836	613	500	CH63	LCX920A0-4A3N2
1030	936	687	560	CH63	LCXH10A0-4A3N2
1150	1045	766	600	CH63	LCXH11A0-4A3N2
1370	1245	913	700	CH74	LCXH13A0-4A3N2
1640	1491	1093	900	CH74	LCXH16A0-4A3N2
2060	1873	1373	1100	CH74	LCXH20A0-4A3N2
2300	2091	1533	1200	CH74	LCXH23A0-4A3N2



## LCX9000 Liquid Cooled Drives



## 525–690 Vac Liquid Cooled Drives

## Motor Output

## Current

Thermal, I <sub>th</sub> (A)	I <sub>L</sub> (A)	I <sub>H</sub> (A)	kW	Chassis	Catalog Number
170	155	113	110	CH61	LCX170A0-5A3N2
208	189	139	132	CH61	LCX208A0-5A3N2
261	237	174	160	CH72	LCX261A0-5A3N2
325	295	217	200	CH72	LCX325A0-5A3N2
385	350	257	250	CH72	LCX385A0-5A3N2
416	378	277	250	CH72	LCX416A0-5A3N2
460	418	307	300	CH72	LCX460A0-5A3N2
502	456	335	355	CH72	LCX502A0-5A3N2
590	536	393	400	CH63	LCX590A0-5A3N2
650	591	433	450	CH63	LCX650A0-5A3N2
750	682	500	500	CH63	LCX750A0-5A3N2
820	745	547	560	CH74	LCX820A0-5A3N2
920	836	613	650	CH74	LCX920A0-5A3N2
1030	936	687	700	CH74	LCXH10A0-5A3N2
1180	1073	787	800	CH74	LCXH11A0-5A3N2
1300	1182	867	900	CH74	LCXH13A0-5A3N2
1500	1364	1000	1000	CH74	LCXH15A0-5A3N2

## 540–675 Vdc Liquid Cooled Inverter Units

## Drive Output

## Current

Thermal I <sub>th</sub> (A)	Rated Cont. I <sub>L</sub> (A)	Rated Cont. I <sub>H</sub> (A)	Motor Output Power		Power Loss c/a/T (kW)	Chassis	Catalog Number
			Optimum Motor at I <sub>th</sub> 400V (kW)	Optimum Motor at I <sub>th</sub> 500V (kW)			
16	15	11	7.5	11	0.4/0.2/0.6	CH3	LCX016A0-4A7B2
22	20	15	11	15	0.5/0.2/0.7	CH3	LCX022A0-4A7B2
31	28	21	15	18.5	0.7/0.2/0.9	CH3	LCX031A0-4A7B2
38	35	25	18.5	22	0.8/0.2/1.0	CH3	LCX038A0-4A7B2
45	41	30	22	30	1.0/0.3/1.3	CH3	LCX045A0-4A7B2
61	55	41	30	37	1.3/0.3/1.5	CH3	LCX061A0-4A7B2
72	65	48	37	45	1.2/0.3/1.5	CH4	LCX072A0-4A7N2
87	79	58	45	55	1.5/0.3/1.8	CH4	LCX087A0-4A7N2
105	95	70	55	75	1.8/0.3/2.1	CH4	LCX105A0-4A7N2
140	127	93	75	90	2.3/0.3/2.6	CH4	LCX140A0-4A7N2
168	153	112	90	110	2.5/0.3/2.8	CH5	LCX168A0-4A7N2
205	186	137	110	132	3.0/0.4/3.4	CH5	LCX205A0-4A7N2
261	237	174	132	160	4.0/0.4/4.4	CH5	LCX261A0-4A7N2
300	273	200	160	200	4.5/0.4/4.9	CH61	LCX300A0-4A7N2
385	350	257	200	250	5.5/0.5/6.0	CH61	LCX385A0-4A7N2
460	418	307	250	315	5.5/0.5/6.0	CH62	LCX460A0-4A7N2
520	473	347	250	355	6.5/0.5/7.0	CH62	LCX520A0-4A7N2
590	536	393	315	400	7.5/0.6/8.1	CH62	LCX590A0-4A7N2

#### LCX9000 Liquid Cooled Drives



#### 540–675 Vdc Liquid Cooled Inverter Units, continued

##### Drive Output

Current			Motor Output Power		Power Loss c/a/T (kW)	Chassis	Catalog Number
Thermal $I_{th}$ (A)	Rated Cont. $I_L$ (A)	Rated Cont. $I_H$ (A)	Optimum Motor at $I_{th}$ 400V (kW)	Optimum Motor at $I_{th}$ 500V (kW)			
650	591	433	355	450	8.5/0.6/9.1	CH62	LCX650A0-4A7N2
730	664	487	400	500	10.0/0.7/10.7	CH62	LCX730A0-4A7N2
820	745	547	450	560	12.5/0.8/13.3	CH63	LCX820A0-4A7N2
920	836	613	500	600	14.4/0.9/15.3	CH63	LCX920A0-4A7N2
1030	936	687	560	700	16.5/1.0/17.5	CH63	LCXH10A0-4A7N2
1150	1045	766	600	750	18.4/1.0/19.5	CH63	LCXH11A0-4A7N2
1370	1245	913	700	900	15.5/1.0/16.5	CH64	LCXH13A0-4A7N2
1640	1491	1093	900	1100	19.5/1.2/20.7	CH64	LCXH16A0-4A7N2
2060	1873	1373	1100	1400	26.5/1.5/28.0	CH64	LCXH20A0-4A7N2
2300	2091	1533	1250	1500	29.6/1.7/31.3	CH64	LCXH23A0-4A7N2
2470	2245	1647	1300	1600	36.0/2.0/38.0	2*CH64	LCXH24A0-4A7N2
2950	2681	1967	1550	1950	39.0/2.4/41.4	2*CH64	LCXH29A0-4A7N2
3710	3372	2473	1950	2450	48.0/2.7/50.7	2*CH64	LCXH37A0-4A7N2
4140	3763	2760	2150	2700	53.0/3.0/66.0	2*CH64	LCXH41A0-4A7N2

#### 710–930 Vdc Liquid Cooled Inverter Unit

##### Drive Output

Current			Motor Output Power		Power Loss c/a/T (kW)	Chassis	Catalog Number
Thermal $I_{th}$ (A)	Rated Cont. $I_L$ (A)	Rated Cont. $I_H$ (A)	Optimum Motor at $I_{th}$ 400V (kW)	Optimum Motor at $I_{th}$ 500V (kW)			
170	155	113	110	160	4.5/0.2/4.7	CH61	LCX170A0-5A7N2
208	189	139	132	200	5.5/0.3/5.8	CH61	LCX208A0-5A7N2
261	237	174	160	250	5.5/0.3/5.8	CH61	LCX261A0-5A7N2
325	295	217	200	300	6.5/0.3/6.8	CH62	LCX325A0-5A7N2
385	350	257	250	355	7.5/0.4/7.9	CH62	LCX385A0-5A7N2
416	378	277	250	355	8.0/0.4/8.4	CH62	LCX416A0-5A7N2
460	418	307	300	400	8.5/0.4/8.9	CH62	LCX460A0-5A7N2
502	456	335	355	450	10.0/0.5/10.5	CH62	LCX502A0-5A7N2
590	536	393	400	560	10.0/0.5/10.5	CH63	LCX590A0-5A7N2
650	591	433	450	600	13.5/0.7/14.2	CH63	LCX650A0-5A7N2
750	682	500	500	700	16.0/0.8/16.8	CH63	LCX750A0-5A7N2
820	745	547	560	800	16.0/0.8/16.8	CH64	LCX820A0-5A7N2
920	836	613	650	850	18.0/0.9/18.9	CH64	LCX920A0-5A7N2
1030	936	687	700	1000	19.0/1.0/20.0	CH64	LCXH10A0-5A7N2
1180	1073	787	800	1100	21.0/1.0/20.1	CH64	LCXH11A0-5A7N2
1300	1182	867	900	1200	27.0/1.4/28.4	CH64	LCXH13A0-5A7N2
1500	1364	1000	1050	1400	32.0/1.6/33.6	CH64	LCXH15A0-5A7N2
1700	1545	1133	1150	1550	N/A	CH64	LCXH17A0-5A7N2
1850	1682	1233	1250	1650	34.2/1.8/36.0	2*CH64	LCXH18A0-5A7N2
2120	1927	1413	1450	1900	37.8/2.0/39.8	2*CH64	LCXH21A0-5A7N2
2340	2127	1560	1600	2100	48.6/2.5/51.1	2*CH64	LCXH23A0-5A7N2
2700	2455	1800	1850	2450	57.6/3.0/60.6	2*CH64	LCXH27A0-5A7N2
3100	2818	2066	2150	2800	N/A	2*CH64	LCXH31A0-5A7N2

## Options

### 9000X Series Option Board Kits

The 9000X Series drives can accommodate a wide selection of expander and adapter option boards to customize the drive for your application needs. The drive's control unit is designed to accept a total of five option boards.

The 9000X Series factory installed standard board configuration includes an A9 I/O board and an A2 relay output board, which are installed in slots A and B.

#### Option Boards

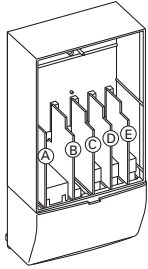

#### Option Board Kits

Option Kit Description <sup>①</sup>	Allowed Slot Locations <sup>②</sup>	Field Installed Catalog Number	Factory Installed Option Designator	SVX Ready Programs						
				Basic	Local/Remote	Standard	MSS	PID	Multi-P.	PFC
<b>Standard I/O Cards</b>										
2 RO (NC-NO)	B	<b>OPTA2</b>	—	■	■	■	■	■	■	■
6 DI, 1 DO, 2 AI, 1AO, 1 +10 Vdc ref, 2 ext +24 Vdc/EXT +24 Vdc	A	<b>OPTA9</b>	—	■	■	■	■	■	■	■
<b>Extended I/O Cards</b>										
2 RO, therm	B	<b>OPTA3</b>	<b>A3</b>	—	■	■	■	■	■	■
Encoder low Volt +5V/15V/24V	C	<b>OPTA4</b>	<b>A4</b>	—	■	■	■	■	■	■
Encoder high Volt +15V/24V	C	<b>OPTA5</b>	<b>A5</b>	—	■	■	■	■	■	■
Dual encoder +15V/24V	C	<b>OPTA7</b>	<b>A7</b>	—	■	■	■	■	■	■
6 DI, 1 DO, 2 AI, 1 AO	A	<b>OPTA8</b>	<b>A8</b>	—	■	■	■	■	■	■
3 DI (encoder 10–24V), out +15V/+24V, 2 DO (pulse+direction)—SPX only	C	<b>OPTAE</b>	<b>AE</b>	■	■	■	■	■	■	■
6 DI, 1 ext +24 Vdc/EXT +24 Vdc	B, C, <b>D</b> , E	<b>OPTB1</b>	<b>B1</b>	—	—	—	—	—	■	■
1 RO (NC-NO), 1 RO (NO), 1 therm	B, C, <b>D</b> , E	<b>OPTB2</b>	<b>B2</b>	—	—	—	—	—	■	■
1 AI (mA isolated), 2 AO (mA isolated), 1 ext +24 Vdc/EXT +24 Vdc	B, C, <b>D</b> , E	<b>OPTB4</b>	<b>B4</b>	—	■	■	■	■	■	■
3 RO (NO)	B, C, <b>D</b> , E	<b>OPTB5</b>	<b>B5</b>	—	—	—	—	—	■	■
1 ext +24 Vdc/EXT +24 Vdc, 3 Pt100	B, C, <b>D</b> , E	<b>OPTB8</b>	<b>B8</b>	—	—	—	—	—	—	—
1 RO (NO), 5 DI 42–240 Vac input	B, C, <b>D</b> , E	<b>OPTB9</b>	<b>B9</b>	—	—	—	—	—	■	■
SPI, absolute encoder	C	<b>OPTBB</b>	<b>BB</b>	—	—	—	—	—	—	—
<b>Communication Cards <sup>③</sup></b>										
Modbus	<b>D</b> , E	<b>OPTC2</b>	<b>C2</b>	■	■	■	■	■	■	■
Johnson Controls N2	<b>D</b> , E	<b>OPTC2</b>	<b>CA</b>	—	—	—	—	—	—	—
Profibus DP	<b>D</b> , E	<b>OPTC3</b>	<b>C3</b>	■	■	■	■	■	■	■
LonWorks	<b>D</b> , E	<b>OPTC4</b>	<b>C4</b>	■	■	■	■	■	■	■
Profibus DP (D9 connector)	<b>D</b> , E	<b>OPTC5</b>	<b>C5</b>	■	■	■	■	■	■	■
CanOpen (slave)	<b>D</b> , E	<b>OPTC6</b>	<b>C6</b>	■	■	■	■	■	■	■
DeviceNet	<b>D</b> , E	<b>OPTC7</b>	<b>C7</b>	■	■	■	■	■	■	■
Modbus (D9 Type connector)	<b>D</b> , E	<b>OPTC8</b>	<b>C8</b>	■	■	■	■	■	■	■
Modbus TCP	<b>D</b> , E	<b>OPTC1</b>	<b>C1</b>	■	■	■	■	■	■	■
Adapter—SPX only	<b>D</b> , E	<b>OPTD1</b>	<b>D1</b>	■	■	■	■	■	■	■
Adapter—SPX only	<b>D</b> , E	<b>OPTD2</b>	<b>D2</b>	■	■	■	■	■	■	■
RS-232 with D9 connection	<b>D</b> , E	<b>OPTD3</b>	<b>D3</b>	■	■	■	■	■	■	■
<b>Keypad</b>										
9000X Series standard keypad	—	<b>KEYPAD-STD</b>	—	—	—	—	—	—	—	■
9000X Series remote mount keypad unit (keypad not included, includes 10 ft cable, keypad holder, mounting hardware)	—	<b>OPTRMT-KIT-9000X</b>	—	—	—	—	—	—	—	—

#### Notes

① AI = Analog Input; AO = Analog Output, DI = Digital Input, DO = Digital Output, RO = Relay Output

② Option card must be installed in one of the slots listed for that card. Slot indicated in bold is the preferred location.

③ OPTC2 is a multi-protocol option card.

### Line Reactors

The line reactor carries out several functions in the liquid cooled drive. Connection of the line reactor is necessary except if you have a component in your system that performs the same tasks (e.g. a transformer). The line

reactor is needed as an essential component for motor control, to protect the input and DC-link components against abrupt changes of current and voltage as well as to function as a protection

against harmonics. The line reactors are included in the standard delivery of liquid-cooled drives (not inverters). However, you can also order your drive without a line reactor.

### Line Reactor Specifications

Drive Rating 480V	Drive Rating 690V	Thermal Current (A)	Nominal Inductance ( $\mu$ H) A/B <sup>①</sup>	Calculated Loss (W)	Choke Catalog Number (690 Vac)
16 to 22A	12 to 23A	23	1900	145	<b>CHK0023N6A0</b>
31 to 38A	31 to 38A	38	1100	170	<b>CHK0038N6A0</b>
45 to 61A	46 to 62A	62	700	210	<b>CHK0062N6A0</b>
72 to 87A	72 to 87A	87	480	250	<b>CHK0087N6A0</b>
105 to 140A	105 to 140A	145	290	380	<b>CHK0145N6A0</b>
168 to 261A	170 to 261A	261	139/187	460	<b>CHK0261N6A0</b>
300 to 385A	325 to 385A 820 to 1180A <sup>②</sup>	400	90/126	570	<b>CHK0400N6A0</b>
460 to 520A 1370A <sup>②</sup>	416 to 502A 1300 to 1500A <sup>②</sup>	520	65/95	610	<b>CHK0520N6A0</b>
590 to 650A 1640A <sup>②</sup>	590 to 650A	650	51/71	840	<b>CHK0650N6A0</b>
730A 2060A <sup>②</sup>	—	730	45/61	850	<b>CHK0730N6A0</b>
820A 2300A <sup>②</sup>	750A	N/A	N/A	N/A	<b>CHK0820N6A0</b>
920 to 1030A	—	1000	30/41	950	<b>CHK1030N6A0</b>
1150A	—	1150	26/36	1000	<b>CHK1150N6A0</b>

**Dimensions**, see Page V6-T36-232.

#### Notes

- <sup>①</sup> Inductances for different supply voltages: A = 400–480 Vac; B = 500–690 Vac.  
<sup>②</sup> Drives require three chokes of the designated catalog number with six-pulse supply.

## Technical Data and Specifications

### LCX9000 Products

Description	Specification
<b>General Specifications</b>	
Line voltage	400 to 500 Vac; 525 to 690 Vac; (–10% to 10%) 465 to 800 Vdc; 640 to 1100 Vdc; (–0 to 0%)
Frequency	50/60 Hz
Line voltage variation	–10% to 10%
Input frequency variation	45–66 Hz
Continuous output current	Rated current at incoming cooling liquid temperature of 30°C
Output frequency	0–320 Hz
Drive efficiency	>95%
Power factor (displacement)	0.96
Liquid coolant pressure	87 psi (6 bar) maximum
Liquid coolant flow rate	1.3 to 7.9 gal./min. (5 to 30 liter/min.) minimum depending on drive size
Liquid coolant fittings	Standard quick connect, NPT
Operating ambient temperature	–10/50°C
Storage temperature	–40/70°C
Humidity	95% maximum (non-condensing)
Altitude	3300 ft (1000 m) maximum without derating
Enclosure	IP00
Warranty	Standard terms, 3 years with certified start-up
<b>Mains Connection</b>	
Input voltage ( $V_{in}$ )	400–500 Vac; 525–690 Vac; (–10%–10%) 465–800 Vdc; 640–1100 Vdc; (–0–0%)
Input frequency ( $f_{in}$ )	45–66Hz
Connection to mains	Once per minute or less (normal case)
<b>Motor Connection</b>	
Output voltage	0– $V_{in}$
Continuous output current	Rated current at nominal inflow cooling water temperature of 30°C; Overload 2 sec./20 sec.
Starting current	Rated current at 2 sec./20 sec. if output frequency <30 Hz and temperature of heatsink <149°F (65°C)
Output frequency	0–320 Hz (standard); 7200 Hz (special software)
Frequency resolution	Application dependent
<b>Control Characteristics</b>	
Control method	Frequency control (V/f) Open loop: Sensorless vector control Closed loop: Frequency control Closed loop: Vector control
Switching frequency 480V ①	Adjustable with parameter 2.6.9 Up to and including 61-Amp size: 1–16 kHz (factory default, 10 kHz) From 72-Amp size: 1–12 kHz (factory default, 3.6 kHz)
575V ①	1–6kHz (factory default, 1.5kHz)
Frequency reference	Analog input: resolution 0.1% (10 bits); accuracy ±1% Panel reference: resolution 0.01 Hz
Field weakening point	30–320 Hz
Acceleration time	0.1–3000 seconds
Deceleration time	0.1–3000 seconds
Braking torque	DC brake: 30% x $T_n$ (without brake option)

Description	Specification
<b>Ambient Conditions</b>	
Ambient operating temperature	14°F (–10°C), no frost to 122°F (50°C) at $I_{th}$ 122 to 158°F (50 to 70°C), derating required
Storage temperature	–40°F to 158°F (–40 to 70°C) No liquid in heatsink under 32°F (0°C)
Relative humidity	5–96% RH, noncondensing, no dripping water
Air quality	Chemical vapors: IEC 721-3-3, unit in operation, class 3C2 Mechanical particles: IEC 721-3-3, unit in operation, class 3S2 (no conductive dust allowed); No corrosive gases
Altitude	Up to 1,000m: 100% load capacity (no derating) Above 1,000m: Derating of 1% per each 100m required
Vibration	EN 50178, EN 60068-2-6; 5–150 Hz Displacement amplitude: 0.25 mm (peak) at 3–31 Hz Max. acceleration amplitude: 1G at 31–150 Hz
Shock	EN 50178, EN 60068-2-27, UPS drop test (for applicable UPS weights) Storage and shipping: Max. 15G, 11 ms (in package)
Enclosure class	IP00 open frame standard in entire kW/hp range
<b>EMC</b>	
Immunity	Fulfills all EMC immunity requirements
Emissions	EMC level N; EMC level T for IT networks
<b>Safety</b>	
Approvals	EN 50178, EN 60204-1, CE, UL, CUL, FI, GOST R, IEC 61800-5 (See unit nameplate for more detailed approvals.)
<b>Control Connections</b>	
Analog input voltage	0 to +10V, $R_i$ = 200 kohm (–10V to +10V joystick control) Resolution 0.1%; accuracy ±1%
Analog input current	0(4)–20 mA, $R_i$ = 250 ohm differential
Digital inputs	6 positive or negative logic; 18–24 Vdc
Auxiliary voltage	+24V, ±15%, max. 250 mA
Output reference voltage	+10V, +3%, max. load 10 mA
Analog output	0(4)–20 mA, $R_i$ max. 500 ohm Resolution 10 bits; accuracy ±2%
Digital outputs	Open collector output, 50 mA/48V
Relay outputs	Two programmable change-over relay outputs Switching capacity: 24 Vdc/8A, 250 Vac/8A, 125 Vdc/0.4A Min. switching load: 5V/10 mA

#### Note

① Derating required if higher switching frequency than the default is used.

#### LCX9000 Products, continued

Description	Specification
<b>Protections</b>	
Overvoltage protection	
480V	911V
575V	1200V
Undervoltage protection	
480V	333V
575V	461V
Ground fault protection	In case of ground fault in motor or motor cable, only the drive is protected
Mains supervision	Trips if any of the input phases are missing (drives only)
Motor phase supervision	Trips if any of the output phases are missing
Unit overtemperature protection	
Alarm limit	149°F (65°C) for heatsink, 158°F (70°C) for circuit boards
Trip limit	158°F (70°C) for heatsink, 185°F (85°C) for circuit boards

Description	Specification
<b>Protections, continued</b>	
Overcurrent protection	Yes
Motor overload protection	Yes
Motor stall protection	Yes
Motor underload protection	Yes
Short-circuit protection	Yes (+24V and +10V reference voltages)
<b>Liquid Cooling</b>	
Allowed cooling agents	Drinking water Water-glycol mixture
Temperature of cooling agent	32 to 86°F (0 to 30°C) at $I_{th}$ for input; 86 to 149°F (30 to 65°C) Max. temperature rise during circulation: 9°F (5°C), no condensation allowed
System max. working pressure	87 psi (6 bar)
System max. peak pressure	580 psi (40 bar)
Pressure loss (at nominal flow)	Varies according to size

### Wiring Diagrams

#### Cooling System Diagrams

##### Example of a Typical Cooling System

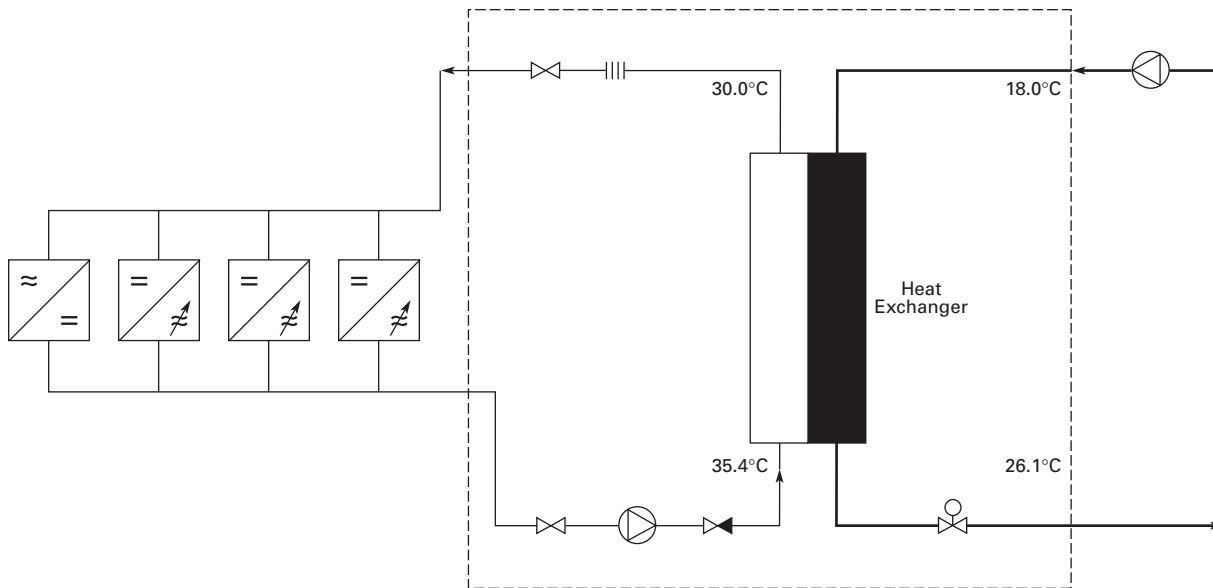

## Example PI-Diagram of a Typical Cooling System and Connections

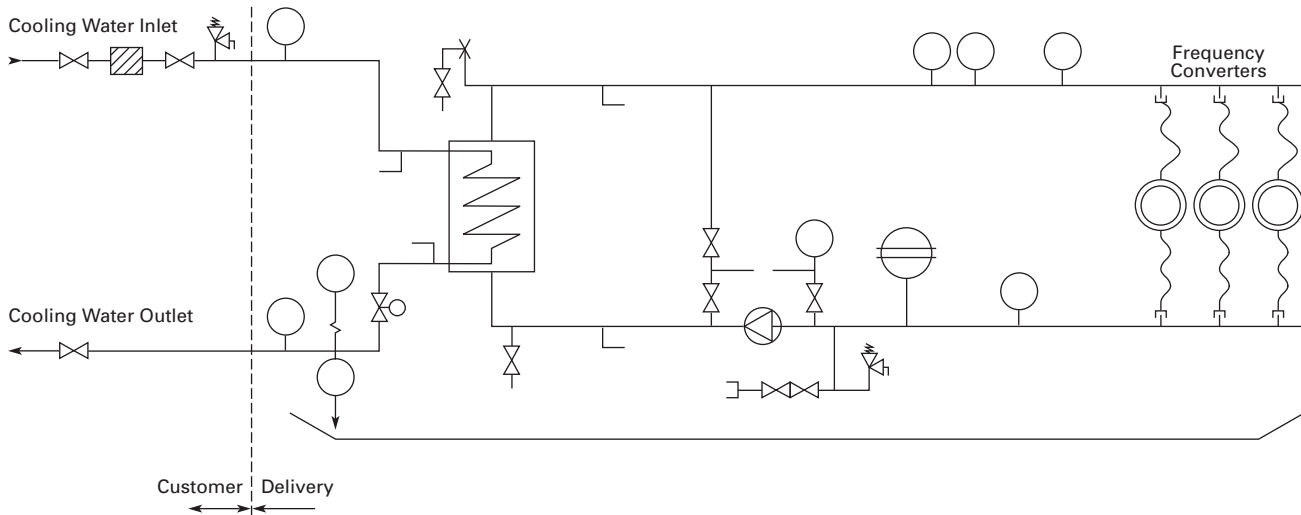

## I/O Board Diagrams

## A9 Option Board Control Wiring

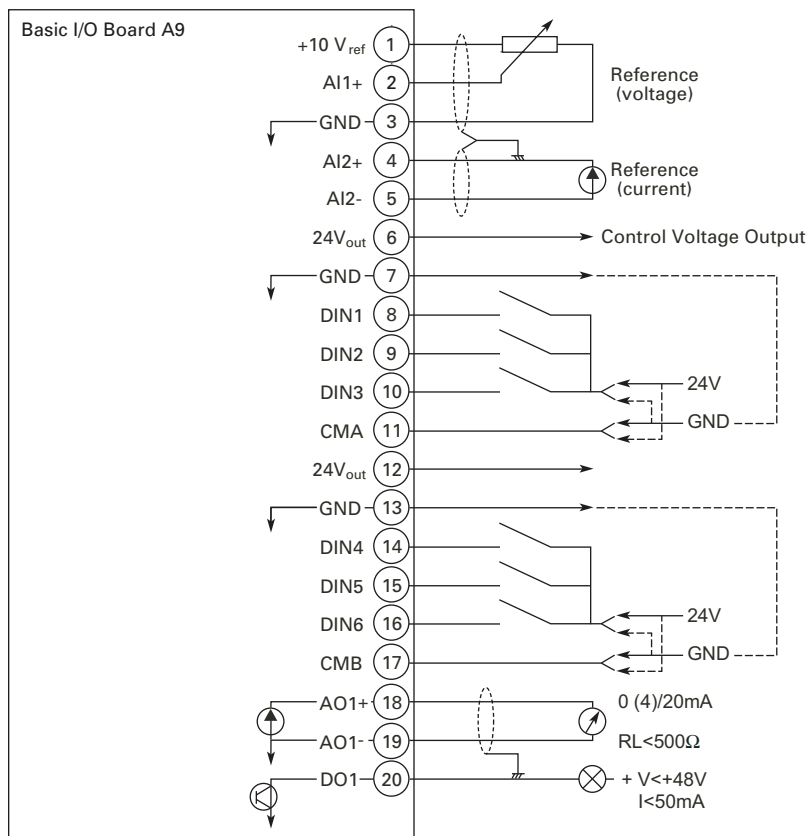

Dotted lines indicate the connections for inverted signals

#### A2 Option Board Wiring

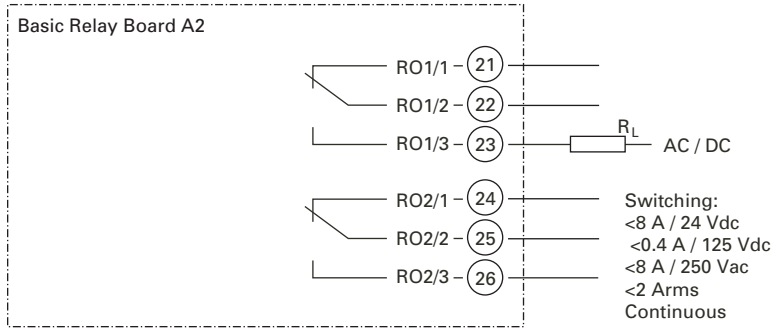

#### Dimensions

Approximate Dimensions in Inches (mm)

#### Line Reactors

##### Sizes Up To 61A

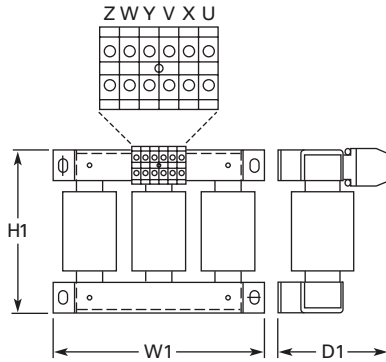

##### Sizes Larger Than 61A

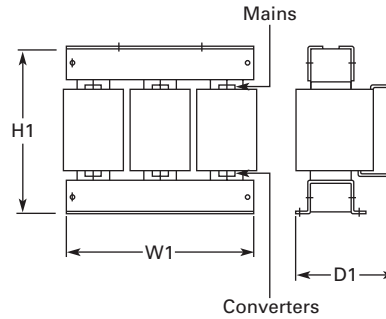

Catalog Number	H1	W1	D1	Weight Lbs (kg)
CHK0023N6A0	7.01 (178)	9.06 (230)	4.76 (121)	22 (10)
CHK0038N6A0	8.23 (209)	10.63 (270)	5.71 (145)	33 (15)
CHK0062N6A0	8.39 (213)	11.81 (300)	6.30 (160)	44 (20)
CHK0087N6A0	9.13 (232)	11.81 (300)	6.69 (170)	57 (26)
CHK0145N6A0	11.50 (292)	11.81 (300)	7.28 (185)	82 (37)
CHK0220N6A0	12.05 (306)	13.86 (352)	7.28 (185)	119 (54)
CHK0325N6A0	13.66 (347)	13.86 (352)	7.28 (185)	132 (60)
CHK0460N6A0	16.54 (423)	13.70 (348)	9.41 (239)	203 (92)
CHK0520N6A0	17.60 (447)	15.51 (394)	10.71 (272)	231 (105)
CHK0590N6A0	20.43 (519)	15.51 (394)	10.71 (272)	276 (125)
CHK0650N6A0	20.51 (521)	15.51 (394)	10.71 (272)	276 (125)
CHK0750N6A0	24.72 (628)	15.51 (394)	11.10 (282)	331 (150)
CHK0820N6A0	24.72 (628)	15.51 (394)	11.10 (282)	331 (150)
CHK1000N6A0	22.68 (576)	19.57 (497)	11.85 (301)	441 (200)
CHK1150N6A0	22.83 (580)	19.57 (497)	11.85 (301)	441 (200)

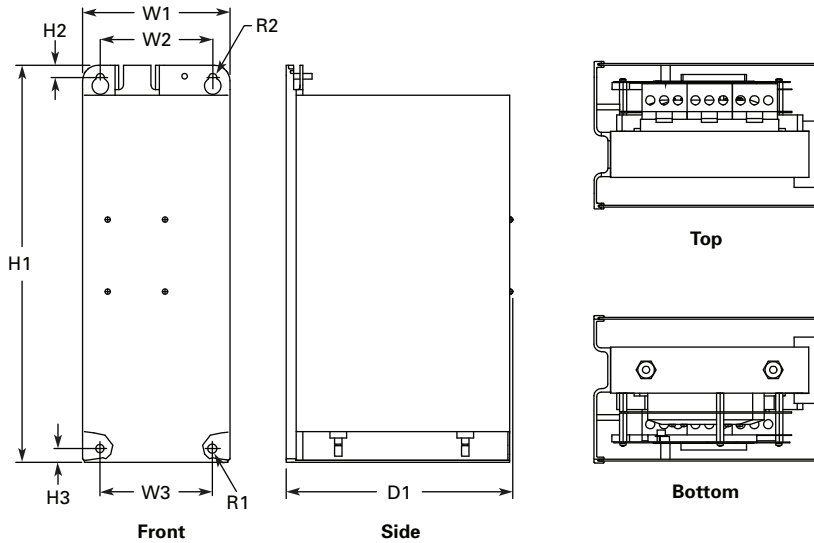

Approximate Dimensions in Inches (mm)

**LCX9000 Drives****Chassis Size, CH3**

Voltage	Amps	H1	H2	H3	D1	W1	W2	W3	R1 Dia.	R2 Dia.	Weight Lbs (kg)
380–500 Vac	16–61	16.97 (431.0)	0.53 (13.5)	0.59 (15.0)	9.69 (246.0)	6.30 (160.0)	4.80 (122.0)	4.80 (122.0)	0.39 (10.0)	0.35 (9.0)	66 (30)

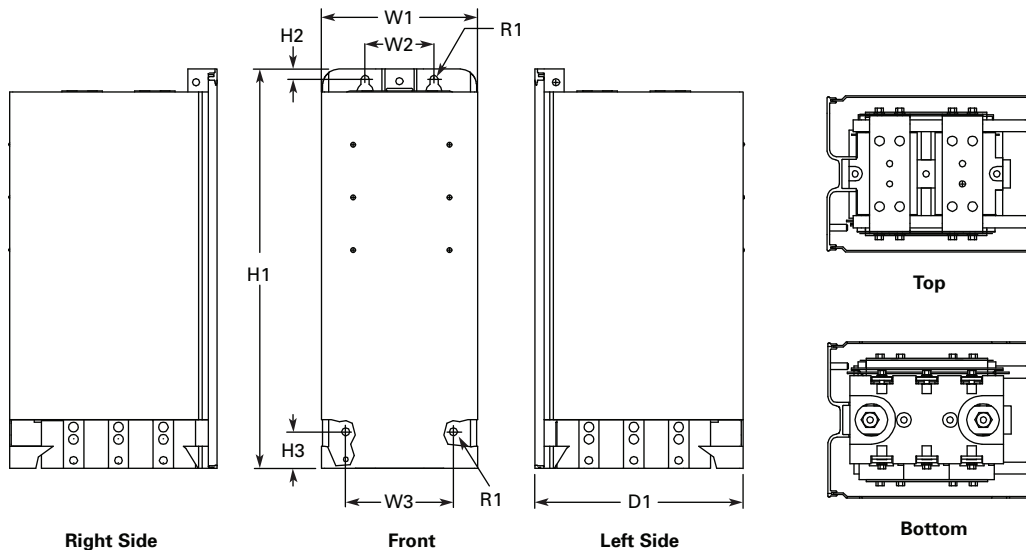
**Chassis Size, CH4**

Voltage	Amps	H1	H2	H3	D1	W1	W2	W3	R1 Dia.	R2 Dia.	Weight Lbs (kg)
380–500 Vac	72–140	19.41 (493.0)	0.49 (12.5)	1.77 (45.0)	10.14 (257.5)	7.60 (193.0)	3.35 (85.0)	5.24 (133.0)	0.39 (10.0)	—	77 (35)

# 36.8

## Adjustable Frequency Drives

### LCX9000 Drives

Approximate Dimensions in Inches (mm)

#### Chassis Size, CH5

36

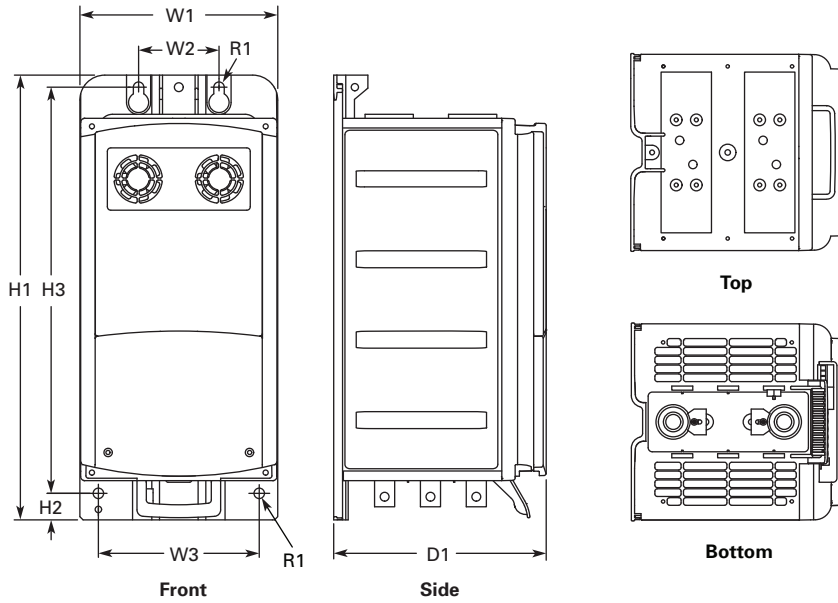

Voltage	Amps	H1	H2	H3	D1	W1	W2	W3	R1 Dia.	R2 Dia.	Weight Lbs (kg)
380–500 Vac	168–261	21.77 (553.0)	1.30 (33.0)	19.88 (505.0)	10.39 (264.0)	9.69 (246)	3.94 (100.0)	7.87 (200.0)	0.51 (13.0)	—	88 (40)

#### Chassis Size, CH61

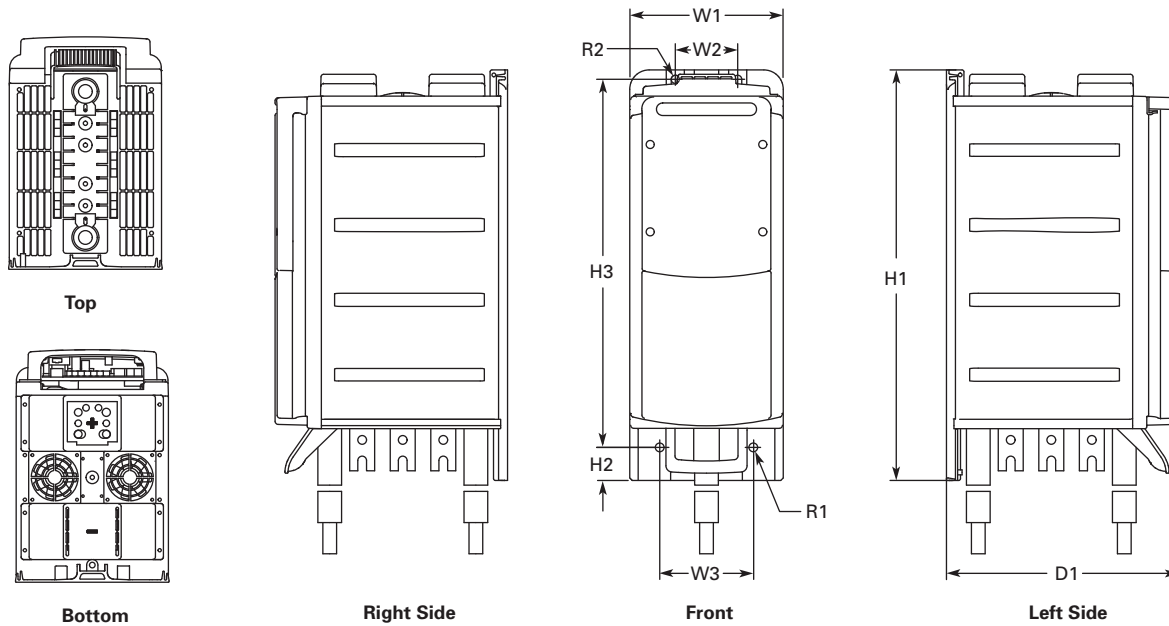

Voltage	Amps	H1	H2	H3	D1	W1	W2	W3	R1 Dia.	R2 Dia.	Weight Lbs (kg)
380–500 Vac	300–385	25.91 (658.0)	2.09 (53.0)	23.23 (590.0)	14.69 (373.0)	9.69 (246.0)	3.94 (100.0)	5.91 (150.0)	0.55 (14.0)	0.51 (13.0)	121 (55)
525–690 Vac	170–208										

Approximate Dimensions in Inches (mm)

## Liquid-Cooled Inverter—Chassis Size, CH62

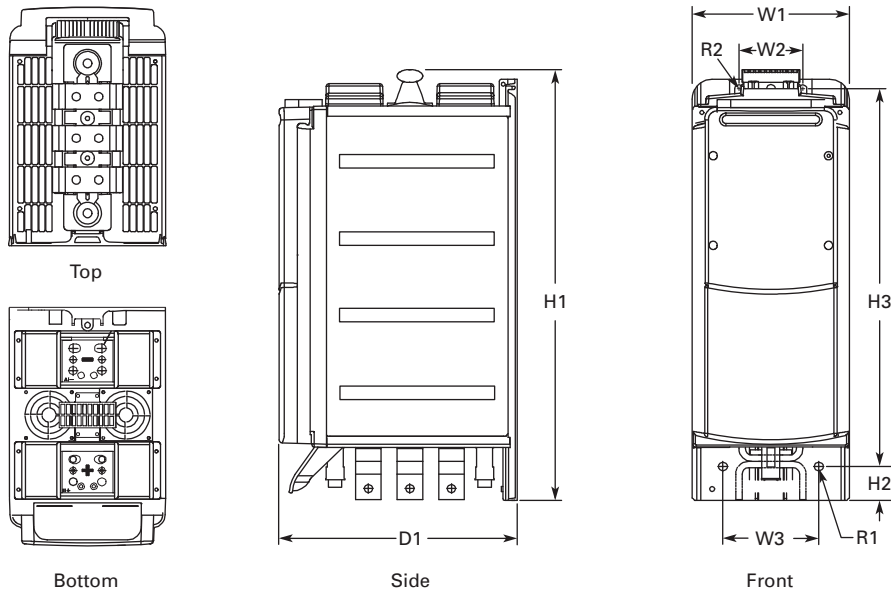

Voltage	Amps	H1	H2	H3	D1	W1	W2	W3	R1 Dia.	R2 Dia.
540–675 Vdc	460–730	26.50 (673)	2.0 (53)	23.23 (590)	14.69 (373)	9.69 (246)	3.94 (100)	5.91 (150)	0.55 (14)	0.51 (13)
710–930 Vdc	325–502									

## Chassis Size, CH63

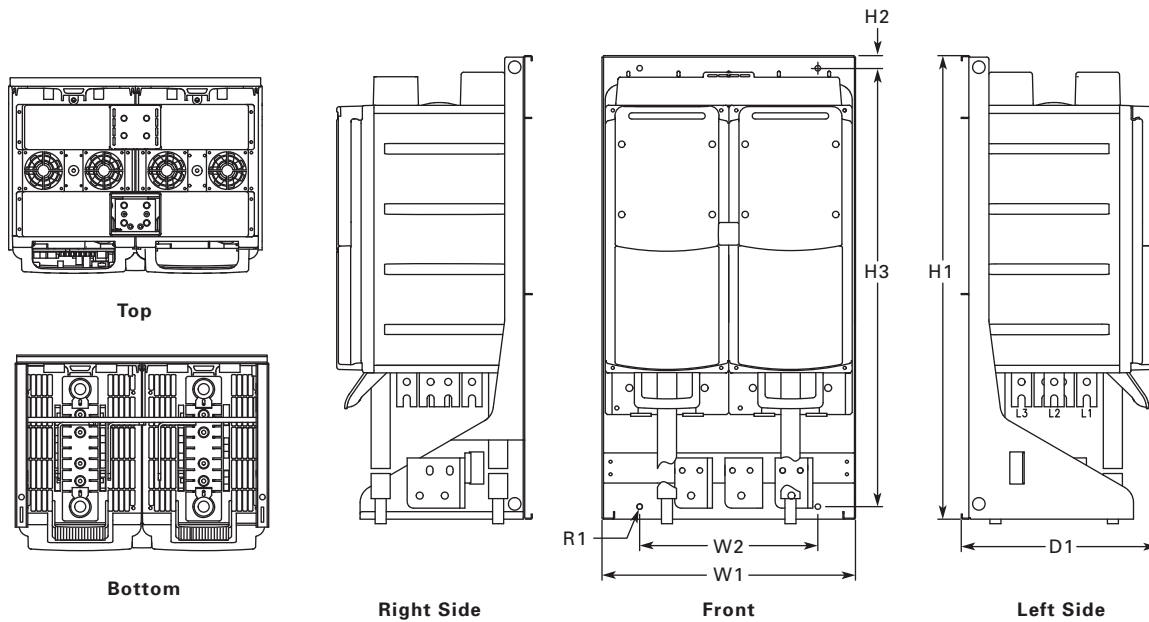

Voltage	Amps	H1	H2	H3	D1	W1	W2	R1 Dia.	Weight Lbs (kg)
380–500 Vac	820–1030	36.36 (923.5)	0.91 (23.0)	34.39 (873.5)	15.35 (390.0)	19.88 (505.0)	13.98 (355.0)	0.43 (11.0)	264 (120)
525–690 Vac	590–750								

# 36.8 Adjustable Frequency Drives

LCX9000 Drives

Approximate Dimensions in Inches (mm)

## Liquid-Cooled Inverter with Mounting Bracket, Chassis Size CH64, IP90

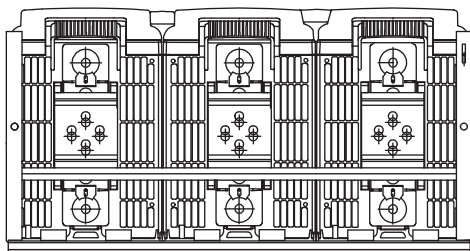

Bottom

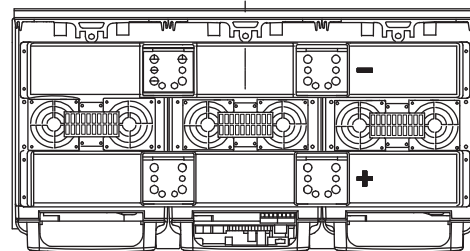

Top

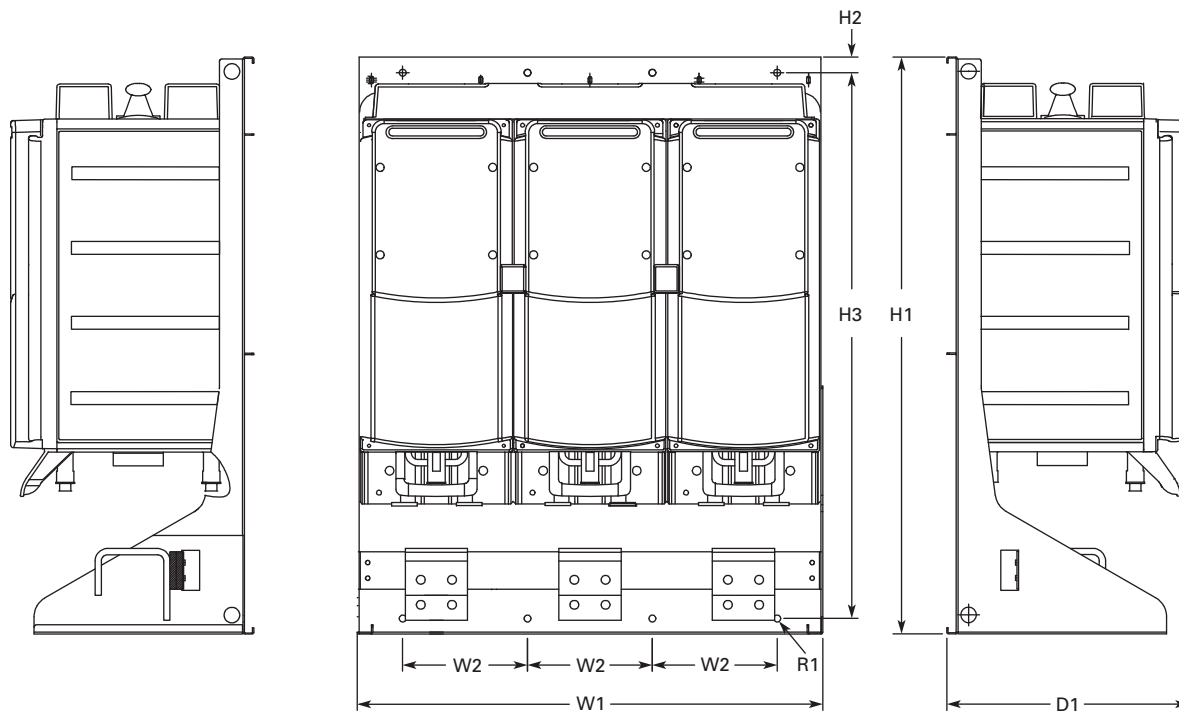

Right Side

Front

Left Side

Voltage	Amps	H1	H2	H3	D1	W1	W2	R1 Dia.
540–675 Vdc	1370–4140	36.38 (924)	1.03 (26)	34.37 (873)	15.35 (390)	29.37 (746)	7.87 (200)	0.43 (11)
710–930 Vdc	820–3100							

Approximate Dimensions in Inches (mm)

## Chassis Size, CH72

36

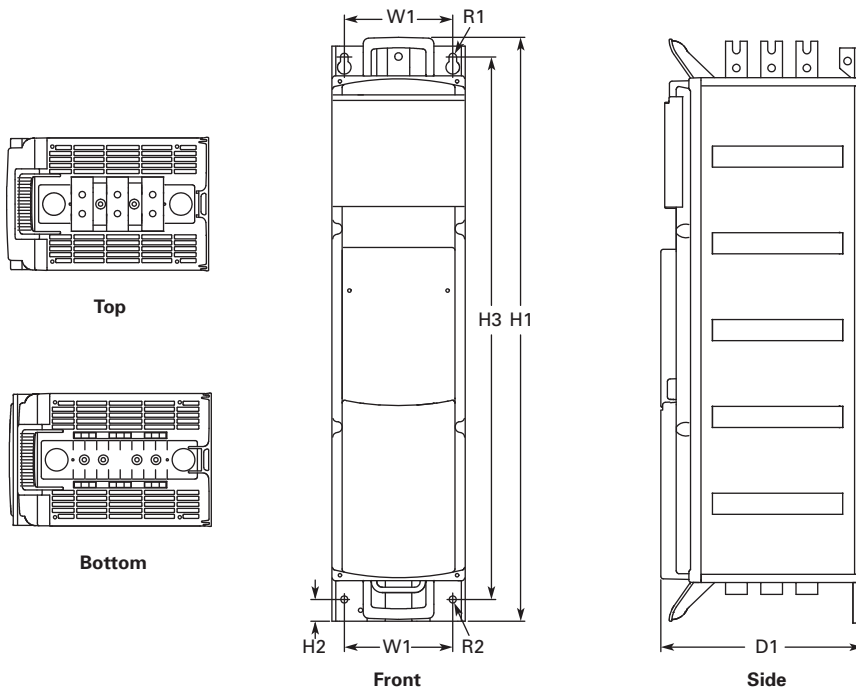

Voltage	Amps	H1	H2	H3	D1	W1	R1 Dia.	R2 Dia.	Weight Lbs (kg)
380–500 Vac	460–730	42.38	1.57	39.37	14.65	7.87	0.55	0.51	198 (90)
525–690 Vac	261–502	(1076.5)	(40.0)	(1000.0)	(372.0)	(200.0)	(14.0)	(13.0)	

# 36.8

## Adjustable Frequency Drives

### LCX9000 Drives

Approximate Dimensions in Inches (mm)

#### Chassis Size, CH74

36

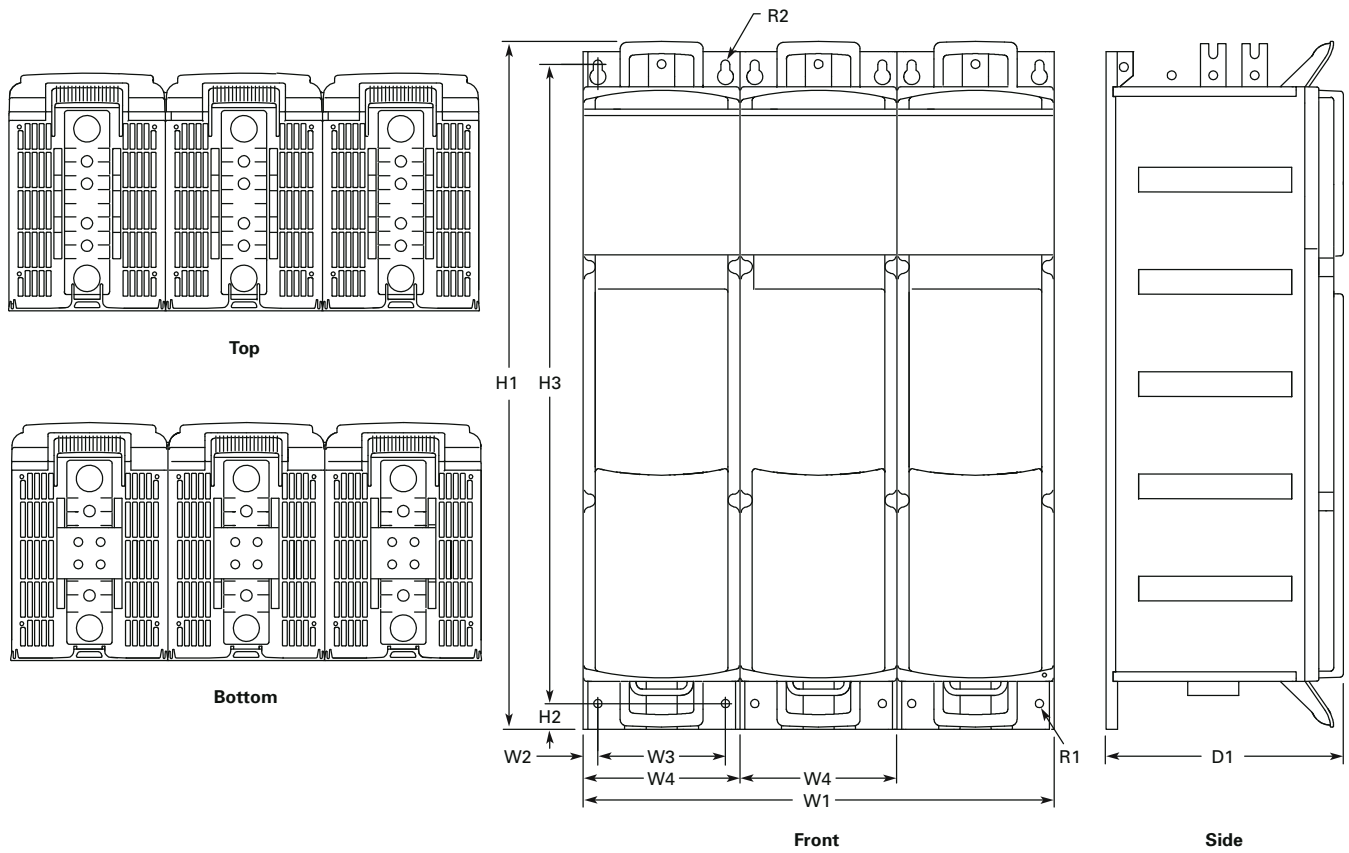

Voltage	Amps	H1	H2	H3	D1	W1	W2	W3	W4	R1 Dia.	R2 Dia.	Weight Lbs (kg)
380–500 Vac	1370–2300	42.38	1.57	39.37	14.65	29.06	0.91	7.87	9.69	0.51	0.55	617 (280)
525–690 Vac	820–1500	(1076.5)	(40.0)	(1000.0)	(372.0)	(738.0)	(23.0)	(200.0)	(246)	(13.0)	(14.0)	

#### Control Unit

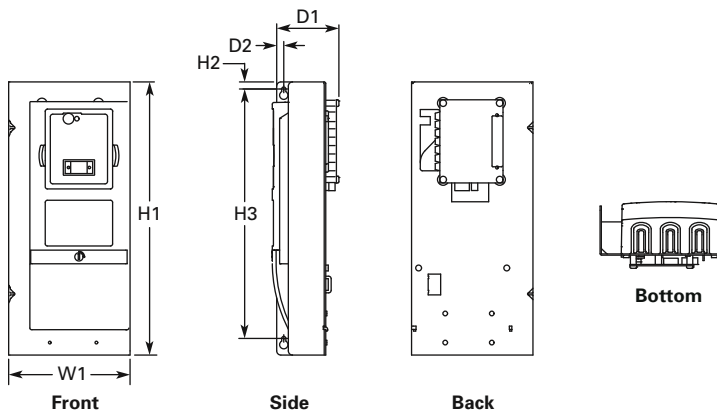

H1	H2	H3	D1	D2	W1
12.93	0.33	11.81	2.95	0.33	5.75
(328.5)	(8.5)	(300.0)	(75.0)	(8.5)	(146.0)

## SPA9000/SPN9000/SPI9000 Common DC Bus Drive Products



## Contents

## Description

## Page

SPA9000/SPN9000/SPI9000 Common DC Bus Drive Products	
Application Description . . . . .	<b>V6-T36-240</b>
Product Comparison . . . . .	<b>V6-T36-240</b>
Features . . . . .	<b>V6-T36-241</b>
Standards and Certifications . . . . .	<b>V6-T36-241</b>
Catalog Number Selection . . . . .	<b>V6-T36-241</b>
Product Selection . . . . .	<b>V6-T36-243</b>
Options . . . . .	<b>V6-T36-246</b>
Technical Data and Specifications . . . . .	<b>V6-T36-247</b>
Wiring Diagrams . . . . .	<b>V6-T36-249</b>
Dimensions . . . . .	<b>V6-T36-250</b>

## Product Description

Eaton offers a comprehensive range of common DC bus drive products. The product family covers a number of front-end units and inverter units in the entire power range from 1-1/2 to 2000 horsepower at 460V and 690V. The drive components are built on the SPX9000 technology.

## Front-End Units

The front-end units convert a mains AC voltage and current into a DC voltage and current. The power is transferred from the mains to a common DC bus (and, in certain cases, vice versa).

The SPA (active front-end) unit is a bidirectional (regenerative) power converter for the front end of a common DC bus drive line up. An external LCL filter is used at the input. This unit is suitable in applications where low mains harmonics are required.

The SPN (non-regenerative front-end) unit is a uni-directional (motoring) power converter for the front-end of a common DC bus drive line-up. The device operates as a diode bridge using diode/thyristor components. A dedicated external choke is used at the input. The unit has the capacity to charge a common DC bus. This unit is suitable as a rectifying device when a "normal" level of harmonics is accepted and no regeneration to the mains is required.

## Inverter Unit

The SPI9000 Inverter Unit is a bidirectional DC-fed power inverter for the supply and control of AC motors. The inverter is supplied from a common DC bus drive line-up. A charging circuit is needed in case a connection to a live DC bus is required. The DC side charging circuit is integrated up to 75 kW (FR4–FR8) and external for higher power ratings (F19–F114).

### Application Description

The common DC bus product portfolio fulfills all solution demands with a flexible architecture.

36

Front end units are selected according to the level of harmonics and power requirements. Typical drive system configurations are illustrated the following figures.

#### SPA + Inverters

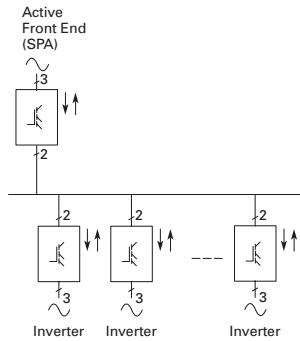

- Low harmonics,  $-P_{\text{mains}} \approx +P_{\text{mains}}/P_{\text{mains}} \leq \sum P_{\text{INU}}$
- Suitable for almost every application

#### SPN + Inverters

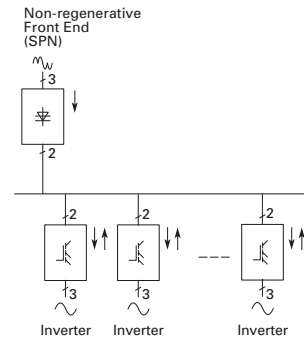

- Low total mains power,  $P_{\text{mains}} \leq \sum P_{\text{INU}}$
- Suitable e.g. for small processing line with un- and recoiler, em-stop coasting

#### Combination Configuration

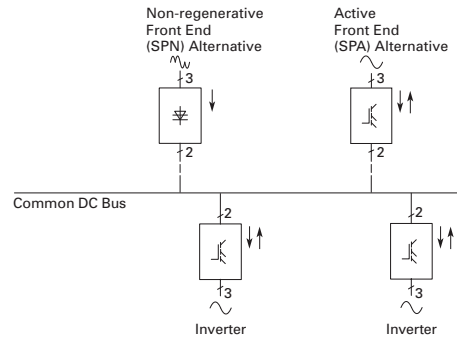

Common DC bus components are used in a multitude of combinations. Drives which are braking can transfer the energy directly to the drives in motoring mode.

### Product Comparison

#### Advantages over Conventional Front Ends

##### Eaton Front Ends vs. Conventional

	Non-Regenerative Front End	Active Front End	Conventional Regenerative Front End ①
Input device	Choke (L)	Filter (LCL)	Choke or auto-transformer (L)
Bridge type	Diode/thyristor bridge	IGBT bridge, two-level type	Anti-parallel connected thyristor bridge
Type of operation	Controlled half-bridge	High frequency modulation (1.5 to 3.6 kHz)	Firing angle controlled
Direction of power	Motoring	Motoring and regenerating	Motoring and regenerating
Charging	Constant current	External required	Usually internal
DC voltage	Nominal (approx. 1.35 alternative $U_N$ )	Stable at +10% of nominal (approx. 110% of 1.35 alternative $U_N$ )	Lowered DC voltage for commutation margin (e.g. 17% fi approx. 83% of 1.35 alternative $U_N$ ) or autotransformer on regenerative bridge
THD	Similar to six-pulse bridge normal <40%	Very low	Similar to six-pulse bridge or worse

#### Note

① Conventional regenerative front end (a.k.a. "anti-parallel thyristor bridge") is not available from Eaton.



## Features

### Standard Features

Feature	SPI9000			SPA	
	FR4, 6, 7	FR8	FI9-FI14	FI9-FI14	FI9
IP00	—	■	■	■	■
IP21	■	—	—	—	—
Air cooling	■	■	■	■	■
Standard board	■	■	■	■	—
Varnished board	—	—	—	—	—
Alphanumeric keypad	■	■	■	■	—
EMC class T (EN 61800-3 for IT networks)	■	■	■	■	■
Safety CE/UL	■	■	■	■	■
Input choke	—	—	—	—	■
LCL filter	—	—	—	■	—
No integrated charging	—	—	■	■	—
Integrated charging (DC side)	■	■	—	—	■
Diode/thyristor rectifier	—	—	—	—	■
IGBT	■	■	■	■	—

### Standards and Certifications

- CE
- UL
- cUL
- EN 61800-5-1 (2003)



### Catalog Number Selection

#### Active Front End

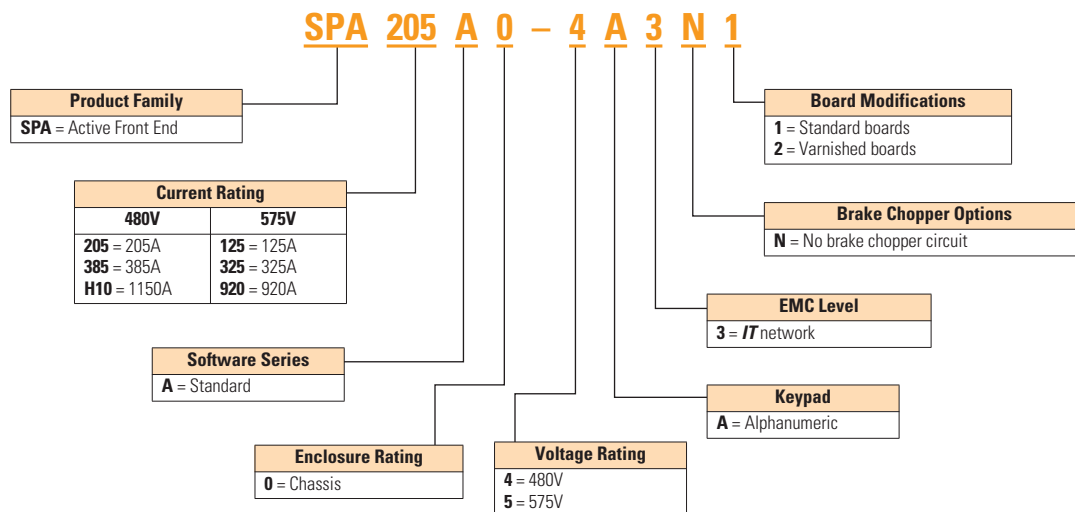

# 36.9

## Adjustable Frequency Drives

SPA9000/SPN9000/SPI9000 Common DC Bus Drive Products

### Non-Regenerative Front End

36

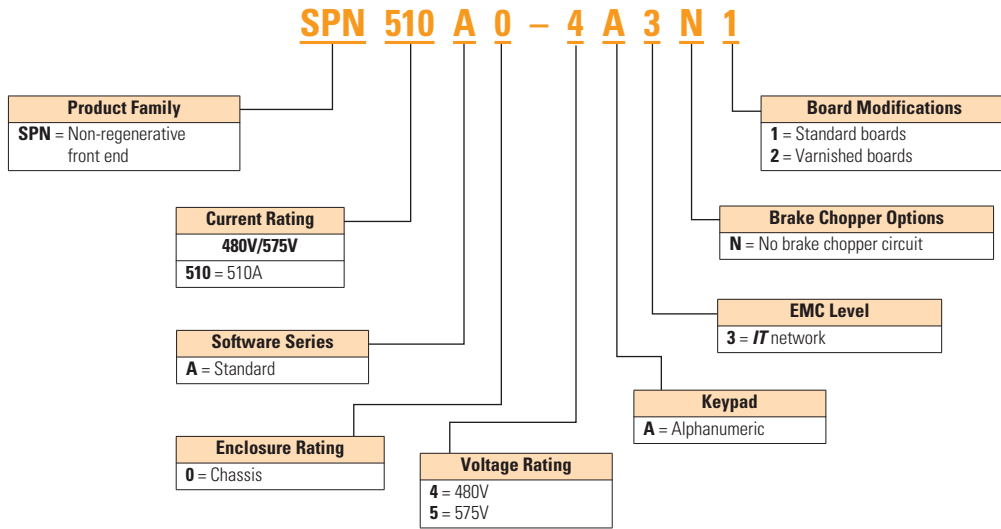

### SPI9000 Inverter Unit

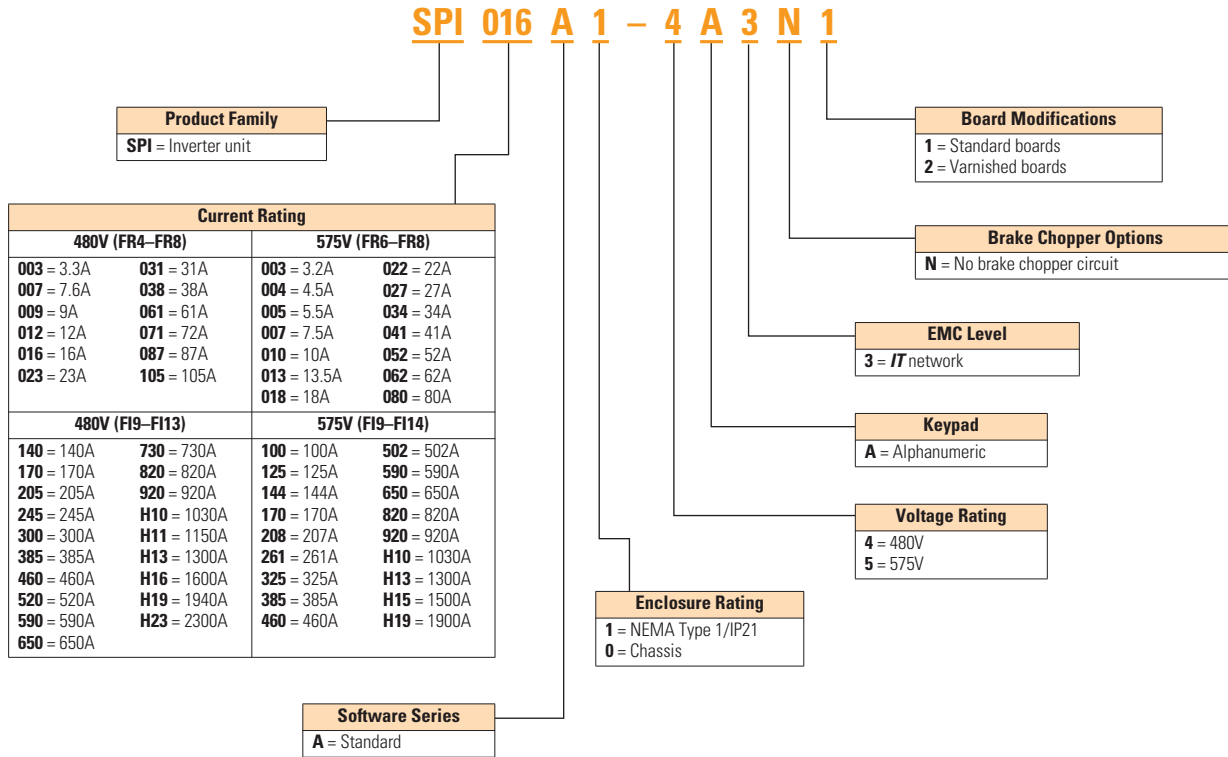

## Product Selection

## Common DC Bus Drive Products



## SPA9000 Active Front End 480V

Frame	Low Overload (AC Current)		High Overload (AC Current)		I <sub>max</sub>	Catalog Number
	I <sub>L-cont</sub> (A)	I <sub>1min</sub> (A)	I <sub>H-cont</sub> (A)	I <sub>1min</sub> (A)	I <sub>2s</sub> (A)	
FI9	261	287	205	308	349	SPA205A0-4A3N1
FI10	460	506	385	578	693	SPA385A0-4A3N1
FI13	1300	1430	1150	1725	2070	SPAH11A0-4A3N1

## SPN9000 Non-Regenerative Front End 480V

Frame	Low Overload (AC Current)		High Overload (AC Current)		I <sub>max</sub>	Catalog Number
	I <sub>L-cont</sub> (A)	I <sub>1min</sub> (A)	I <sub>H-cont</sub> (A)	I <sub>1min</sub> (A)	I <sub>2s</sub> (A)	
FI9	520	572	460	690	828	SPN460A0-4A3N1

## SPI9000 Inverter Unit 480V

Frame	Low Overload (AC Current)		High Overload (AC Current)		I <sub>max</sub>	Catalog Number
	I <sub>L-cont</sub> (A)	I <sub>1min</sub> (A)	I <sub>H-cont</sub> (A)	I <sub>1min</sub> (A)	I <sub>2s</sub> (A)	
FR4	4.3	4.7	3.3	5	6.2	SPI003A1-4A3N1
	9	9.9	7.6	11.4	14	SPI007A1-4A3N1
	12	13.2	9	13.5	18	SPI009A1-4A3N1
FR6	16	17.6	12	18	24	SPI012A1-4A3N1
	23	25.3	16	24	32	SPI016A1-4A3N1
	31	34	23	35	46	SPI023A1-4A3N1
	38	42	31	47	62	SPI031A1-4A3N1
	46	51	38	57	76	SPI038A1-4A3N1
	72	79	61	92	122	SPI061A1-4A3N1
FR7	87	96	72	108	144	SPI072A1-4A3N1
	105	116	87	131	174	SPI087A1-4A3N1
	140	154	105	158	210	SPI105A0-4A3N1
FR8	170	187	140	210	280	SPI140A0-4A3N1
	205	226	170	255	336	SPI170A0-4A3N1
	261	287	205	308	349	SPI205A0-4A3N1
	300	330	245	379	444	SPI245A0-4A3N1
FI10	385	424	300	450	540	SPI300A0-4A3N1
	460	506	385	578	693	SPI385A0-4A3N1
	520	572	460	690	828	SPI460A0-4A3N1
FI12	590	649	520	780	936	SPI520A0-4A3N1
	650	715	590	885	1062	SPI590A0-4A3N1
	730	803	650	975	1170	SPI650A0-4A3N1
	820	902	730	1095	1314	SPI730A0-4A3N1
	920	1012	820	1230	1476	SPI820A0-4A3N1
FI13	1030	1133	920	1380	1656	SPI920A0-4A3N1
	1150	1265	1030	1545	1854	SPIH10A0-4A3N1
	1300	1430	1150	1720	2070	SPIH11A0-4A3N1
	1450	1595	1300	1950	2340	SPIH13A0-4A3N1
FI14	1770	1947	1600	2400	2880	SPIH16A0-4A3N1
	2150	2365	1940	2910	3492	SPIH19A0-4A3N1

**Note**For filter and line reactor information, see [Page V6-T36-245](#).

Common DC Bus Drive Products



36

#### SPA9000 Active Front End 575V

Frame	Low Overload (AC Current)		High Overload (AC Current)		I <sub>max</sub> I <sub>2s</sub> (A)	Catalog Number
	I <sub>L-cont</sub> (A)	I <sub>1min</sub> (A)	I <sub>H-cont</sub> (A)	I <sub>1min</sub> (A)		
FI9	144	158	125	188	213	SPA125A0-5A3N1
FI10	385	424	325	488	585	SPA325A0-5A3N1
FI13	1030	1133	920	1380	1656	SPA920A0-5A3N1

#### SPN9000 Non-Regenerative Front End 575V

Frame	Low Overload (AC Current)		High Overload (AC Current)		I <sub>max</sub> I <sub>2s</sub> (A)	Catalog Number
	I <sub>L-cont</sub> (A)	I <sub>1min</sub> (A)	I <sub>H-cont</sub> (A)	I <sub>1min</sub> (A)		
FI9	600	660	510	732	888	SPN510A0-5A3N1

#### SPI9000 Inverter Unit 575V

Frame	Low Overload (AC Current)		High Overload (AC Current)		I <sub>max</sub> I <sub>2s</sub> (A)	Catalog Number
	I <sub>L-cont</sub> (A)	I <sub>1min</sub> (A)	I <sub>H-cont</sub> (A)	I <sub>1min</sub> (A)		
FR6	4.5	5	3.2	5	6.4	SPI003A1-5A3N1
	5.5	6	4.5	7	9	SPI004A1-5A3N1
	7.5	8	5.5	8	11	SPI005A1-5A3N1
	10	11	7.5	11	15	SPI007A1-5A3N1
	13.5	15	10	15	20	SPI010A1-5A3N1
	18	20	13.5	20	27	SPI013A1-5A3N1
	22	24	18	27	36	SPI018A1-5A3N1
	27	30	22	33	44	SPI022A1-5A3N1
FR7	34	37	27	41	54	SPI027A1-5A3N1
	41	45	34	51	68	SPI034A1-5A3N1
FR8	52	57	41	62	82	SPI041A1-5A3N1
	62	68	52	78	104	SPI052A0-5A3N1
FR8	80	88	62	93	124	SPI062A0-5A3N1
	100	110	80	120	160	SPI080A0-5A3N1
	125	138	100	150	200	SPI100A0-5A3N1
FI9	144	158	125	188	213	SPI125A0-5A3N1
	170	187	144	216	245	SPI144A0-5A3N1
	208	229	170	255	289	SPI170A0-5A3N1
	261	287	208	312	375	SPI208A0-5A3N1
FI10	325	358	261	392	470	SPI261A0-5A3N1
	385	424	325	488	585	SPI325A0-5A3N1
	460	506	385	578	693	SPI385A0-5A3N1
FI12	502	552	460	690	828	SPI460A0-5A3N1
	590	649	502	753	904	SPI502A0-5A3N1
	650	715	590	885	1062	SPI590A0-5A3N1
	750	825	650	975	1170	SPI650A0-5A3N1
	920	1012	820	1230	1476	SPI820A0-5A3N1
FI13	1030	1133	920	1380	1656	SPI920A0-5A3N1
	1180	1298	1030	1464	1755	SPIH10A0-5A3N1
	1500	1650	1300	1950	2340	SPIH13A0-5A3N1
FI14	1900	2090	1500	2250	2700	SPIH15A0-5A3N1
	2250	2475	1900	2782	3335	SPIH19A0-5A3N1

**Note**

For filter and line reactor information, see Page V6-T36-245.

**LCL Filters****LCL Filters for Active Front End (480V)**

Amps	Catalog Number	Amps	Catalog Number
10	REG 10 5 0	270	REG 270 5 0
18	REG 18 5 0	410	REG 410 5 0
32	REG 32 5 0	580	REG 580 5 0
48	REG 48 5 0	840	REG 840 5 0
75	REG 75 5 0	1160	REG 1160 5 0
110	REG 110 5 0	1480	REG 1480 5 0
180	REG 180 5 0		

**LCL Filters for Active Front End (690V)**

Amps	Catalog Number	Amps	Catalog Number
14	REG 14 6 0	287	REG 287 6 0
23	REG 23 6 0	390	REG 390 6 0
35	REG 35 6 0	460	REG 460 6 0
52	REG 52 6 0	620	REG 620 6 0
85	REG 85 6 0	780	REG 780 6 0
122	REG 122 6 0	920	REG 920 6 0
185	REG 185 6 0	1180	REG 1180 6 0

**Line Reactor****Line Reactor for Non-Regenerative Front End (480/575VV)**

Amps	Watts Losses	Catalog Number
600	493	CHK600

#### Options

#### 9000X Series Option Board Kits

36

The 9000X Series drives can accommodate a wide selection of expander and adapter option boards to customize the drive for your application needs. The drive's control unit is designed to accept a total of five option boards.

The 9000X Series factory installed standard board configuration includes an A9 I/O board and an A2 relay output board, which are installed in slots A and B.

#### Option Boards

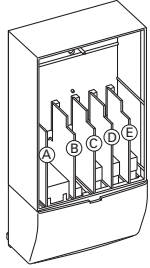

#### Option Board Kits

Option Kit Description <sup>①</sup>	Allowed Slot Locations <sup>②</sup>	Field Installed Catalog Number	Factory Installed Option Designator	SVX Ready Programs						
				Basic	Local/Remote	Standard	MSS	PID	Multi-P.	PFC
<b>Standard I/O Cards</b>										
2 RO (NC-NO)	B	<b>OPTA2</b>	—	■	■	■	■	■	■	■
6 DI, 1 DO, 2 AI, 1AO, 1 +10 Vdc ref, 2 ext +24 Vdc/EXT +24 Vdc	A	<b>OPTA9</b>	—	■	■	■	■	■	■	■
<b>Extended I/O Cards</b>										
2 RO, therm	B	<b>OPTA3</b>	<b>A3</b>	—	■	■	■	■	■	■
Encoder low volt +5V/15V/24V	C	<b>OPTA4</b>	<b>A4</b>	—	■	■	■	■	■	■
Encoder high volt +15V/24V	C	<b>OPTA5</b>	<b>A5</b>	—	■	■	■	■	■	■
Double encoder	C	<b>OPTA7</b>	<b>A7</b>	■	■	■	■	■	■	■
6 DI, 1 DO, 2 AI, 1 AO	A	<b>OPTA8</b>	<b>A8</b>	—	■	■	■	■	■	■
3 DI (encoder 10–24V), out +15V/+24V, 2 DO (pulse+direction)	C	<b>OPTAE</b>	<b>AE</b>	■	■	■	■	■	■	■
6 DI, 1 ext +24 Vdc/EXT +24 Vdc	B, C, <b>D</b> , E	<b>OPTB1</b>	<b>B1</b>	—	—	—	—	—	■	■
1 RO (NC-NO), 1 RO (NO), 1 therm	B, C, <b>D</b> , E	<b>OPTB2</b>	<b>B2</b>	—	—	—	—	—	■	■
1 AI (mA isolated), 2 AO (mA isolated), 1 ext +24 Vdc/EXT +24 Vdc	B, C, <b>D</b> , E	<b>OPTB4</b>	<b>B4</b>	—	■	■	■	■	■	■
3 RO (NO)	B, C, <b>D</b> , E	<b>OPTB5</b>	<b>B5</b>	—	—	—	—	—	■	■
1 ext +24 Vdc/EXT +24 Vdc, 3 Pt100	B, C, <b>D</b> , E	<b>OPTB8</b>	<b>B8</b>	—	—	—	—	—	—	—
1 RO (NO), 5 DI 42–240 Vac input	B, C, <b>D</b> , E	<b>OPTB9</b>	<b>B9</b>	—	—	—	—	—	■	■
SPI, absolute encoder	C	<b>OPTBB</b>	<b>BB</b>	—	—	—	—	—	—	—
<b>Communication Cards <sup>③</sup></b>										
Modbus	D, <b>E</b>	<b>OPTC2</b>	<b>C2</b>	■	■	■	■	■	■	■
Johnson Controls N2	D, <b>E</b>	<b>OPTC2</b>	<b>CA</b>	—	—	—	—	—	—	—
Modbus TCP	D, <b>E</b>	<b>OPTCI</b>	<b>CI</b>	■	■	■	■	■	■	■
BACnet	D, <b>E</b>	<b>OPTCJ</b>	<b>CJ</b>	■	■	■	■	■	■	■
Ethernet IP	D, <b>E</b>	<b>OPTCK</b>	<b>CK</b>	■	■	■	■	■	■	■
Profibus DP	D, <b>E</b>	<b>OPTC3</b>	<b>C3</b>	■	■	■	■	■	■	■
LonWorks	D, <b>E</b>	<b>OPTC4</b>	<b>C4</b>	■	■	■	■	■	■	■
Profibus DP (D9 connector)	D, <b>E</b>	<b>OPTC5</b>	<b>C5</b>	■	■	■	■	■	■	■
CanOpen (slave)	D, <b>E</b>	<b>OPTC6</b>	<b>C6</b>	■	■	■	■	■	■	■
DeviceNet	D, <b>E</b>	<b>OPTC7</b>	<b>C7</b>	■	■	■	■	■	■	■
Modbus (D9 type connector)	D, <b>E</b>	<b>OPTC8</b>	<b>C8</b>	■	■	■	■	■	■	■
Adapter	D, <b>E</b>	<b>OPTD1</b>	<b>D1</b>	■	■	■	■	■	■	■
Adapter	D, <b>E</b>	<b>OPTD2</b>	<b>D2</b>	■	■	■	■	■	■	■
RS-232 with D9 connection	D, <b>E</b>	<b>OPTD3</b>	<b>D3</b>	■	■	■	■	■	■	■
<b>Keypad</b>										
9000X Series local/remote keypad (replacement keypad)	—	<b>KEYPAD-LOC/REM</b>	—	—	—	—	—	—	—	■
9000X Series remote mount keypad unit (keypad not included, includes 10 ft cable, keypad holder, mounting hardware)	—	<b>OPTRMT-KIT-9000X</b>	—	—	—	—	—	—	—	—
9000X Series RS-232 cable, 13 ft	—	<b>PP00104</b>	—	—	—	—	—	—	—	—

#### Notes

- ① AI = Analog Input; AO = Analog Output, DI = Digital Input, DO = Digital Output, RO = Relay Output
- ② Option card must be installed in one of the slots listed for that card. Slot indicated in bold is the preferred location.
- ③ OPTC2 is a multi-protocol option card.

## Technical Data and Specifications

### SPA9000/SPN9000/SPI9000

Description	Specification
<b>Supply Connection</b>	
Input voltage $U_{in}$ (AC) front end modules	380–500 Vac/525–690 Vac –10% to 10%
Input voltage $U_{in}$ (DC) inverter	465–800 Vdc/640–1100 Vdc –0% to 0%, the waviness of the inverter supply voltage, formed in rectification of the electric network's alternating voltage in basic frequency, must be less than 50V peak-to-peak
Output voltage $U_{out}$ (AC) inverter	$3 \sim 0 - U_{in}/1.4$
Output voltage $U_{out}$ (DC) active front end module	$10.10 \times 1.35 \times U_{in}$ (factory default)
Output voltage $U_{out}$ (DC) non-regenerative front end module	$1.35 \times U_{in}$
<b>Ambient Conditions</b>	
Ambient operating temperature	14 (no frost) to 122°F (–10 to 50°C): $I_H$ 14 (no frost) to 104°F (–10 to 40°C): $I_L$
Storage temperature	–40 to 158°F (–40 to 70°C)
Relative humidity	0 to 95% RH, non-condensing, non-corrosive, no dripping water
Air quality	
Chemical vapors	IEC 721-3-3, unit in operation, class 3C2
Mechanical particles	IEC 721-3-3, unit in operation, class 3S2
Altitude	100% load capacity (no derating) up to 1000m 1% derating for each 100m above 1000m; max. 3000m
Vibration	5–150 Hz
EN50178/EN60068-2-6	Displacement amplitude 0.25 mm (peak) at 3–15.8 Hz Max acceleration amplitude 1G at 15.8–150 Hz
Shock EN50178, EN60068-2-27	UPS Drop Test (for applicable UPS weights) Storage and shipping: max 15G, 11 ms (in package)
Cooling capacity required	Approximately 2%
Cooling air required	FR4 41 cfm, FR6 250 cfm, FR7 250 cfm, FR8 383 cfm FR9 677 cfm, FR10 824 cfm, FR12 1648 cfm, FR13 2472 cfm
Unit enclosure class	FR4–FR7 NEMA Type 1/IP21; FR8, FR9–FR14 chassis (IP00)
<b>EMC (at fault settings)</b>	
Immunity	Fulfill all EMC immunity requirements
<b>Safety</b>	
Approvals	CE, UL, cUL, EN 61800-5-1 (2003), see unit nameplate for more detailed approvals
<b>Control Connections</b>	
Analog input voltage	0–10V, $R_i = 200$ kohms, (–10V to 10V joystick control) Resolution 0.1%, accuracy $\pm 1\%$
Analog input current	0(4)–20 mA, $R_i = 250$ ohms differential
Digital inputs	6, positive or negative logic; 18–30 Vdc
Auxiliary voltage	+24V, $\pm 15\%$ , max. 250 mA
Output reference voltage	+10V, +3%, max. load 10 mA
Analog output	0(4)–20 mA; RL max. 500 ohms; resolution 10 bits Accuracy $\pm 2\%$
Digital outputs	Open collector output, 50 mA/48V
Relay outputs	2 programmable change-over relay outputs Switching capacity: 24 Vdc/8A, 250 Vac/8A, 125 Vdc/0.4A Min. switching load: 5V/10 mA

## SPA9000/SPN9000/SPI9000, continued

Description	Specification
<b>Protections</b>	
Overvoltage protection	480V/911 Vdc, 575V/1200 Vdc
Undervoltage protection	480V/333 Vdc, 575V/460 Vdc
Ground fault protection	In case of ground fault in motor or motor cable, only the inverter is protected
Motor phase supervision	Trips if any of the output phases is missing
Overcurrent protection	Yes
Unit overtemperature protection	Yes
Motor overload protection	Yes
Motor stall protection	Yes
Motor underload protection	Yes
Short circuit protection of 24V and 10V reference voltages	Yes

## Input Fuses

SHT fuses can be assembled into same-size DIN fuse base.

## SPA9000/SPN9000/SPI9000

Module Component	Frame	Bussman Fuse Type (aR)	Size	U <sub>N</sub> (V)	I <sub>N</sub> (A)	Qty.
<b>Inverter Units</b>						
SPI003A1-4	FR4	170M1560	0	690	20	2
SPI007A1-4	FR4	170M1562	0	690	63	2
SPI009A1-4	FR4	170M1562	0	690	63	2
SPI012A1-4	FR6	170M1565	0	690	63	2
SPI016A1-4	FR6	170M1565	0	690	63	2
SPI023A1-4	FR6	170M1565	0	690	63	2
SPI031A1-4	FR6	170M1567	0	690	100	2
SPI038A1-4	FR6	170M1567	0	690	100	2
SPI061A1-4	FR7	170M1570	0	690	200	2
SPI072A1-4	FR7	170M1570	0	690	200	2
SPI087A1-4	FR7	170M1571	0	690	250	2
SPI105A0-4	FR8	170M3819	DIN1	690	400	2
SPI140A0-4	FR8	170M3819	DIN1	690	400	2
SPI170A0-4	FR8	170M3819	DIN1	690	400	2
SPI205A0-4	FI9	170M6812	DIN3	690	800	2
SPI245A0-4	FI9	170M6812	DIN3	690	800	2
SPI300A0-4	FI10	170M8547	3SHT	690	1250	2
SPI385A0-4	FI10	170M8547	3SHT	690	1250	2
SPI460A0-4	FI10	170M8547	3SHT	690	1250	2
SPI520A0-4	FI12	170M8547	3SHT	690	1250	2 x 2
SPI590A0-4	FI12	170M8547	3SHT	690	1250	2 x 2
SPI650A0-4	FI12	170M8547	3SHT	690	1250	2 x 2
SPI730A0-4	FI12	170M8547	3SHT	690	1250	2 x 2
SPI820A0-4	FI12	170M8547	3SHT	690	1250	2 x 2
SPI920A0-4	FI12	170M8547	3SHT	690	1250	2 x 2
SPIH10A0-4	FI13	170M8547	3SHT	690	1250	6
SPIH11A0-4	FI13	170M8547	3SHT	690	1250	6
SPIH13A0-4	FI13	170M8547	3SHT	690	1250	6
SPIH16A0-4	FI14	170M8547	3SHT	690	1250	2 x 6
SPIH19A0-4	FI14	170M8547	3SHT	690	1250	2 x 6
SPIH23A0-4	FI14	170M8547	3SHT	690	1250	2 x 6



SHT fuses can be assembled into same-size DIN fuse base.

### SPA9000/SPN9000/SPI9000, continued

Module Component	Frame	Bussman Fuse Type (aR)	Size	$U_N$ (V)	$I_N$ (A)	Qty.
<b>Active Front Ends</b>						
SPA205A0-4	FI9	170M6202	3SHT	1250	500	3
SPA385A0-4	FI10	170M6277	3SHT	1250	1000	3
SPAH10A0-4	FI13	170M6277	3SHT	1250	1000	3 x 3
<b>Non-Regenerative Front Ends</b>						
SPN468A0-4	FI9	170M8547	3SHT	690	1250	3

## Wiring Diagrams

### SPA9000—Active Front End

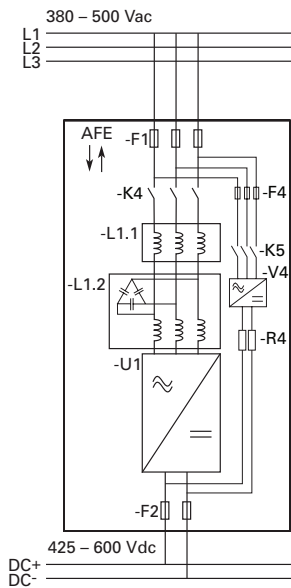

### SPN9000—Non-Regenerative Front End

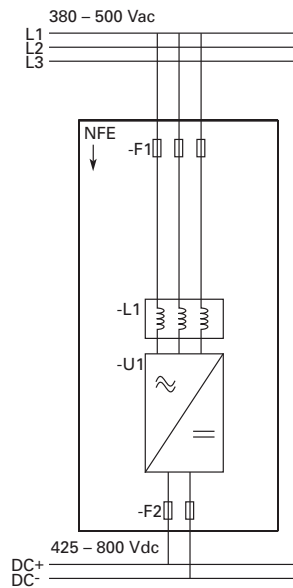

### SPI9000—Inverter Unit (FR4-FR8)

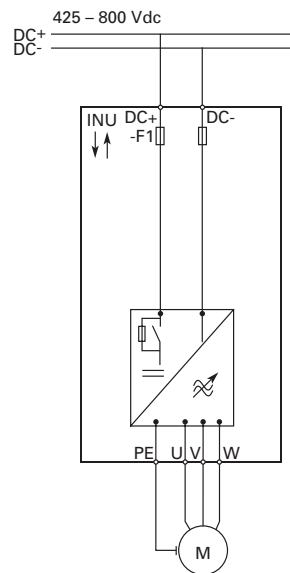

### SPI9000—Inverter Unit (FI9-FI14)

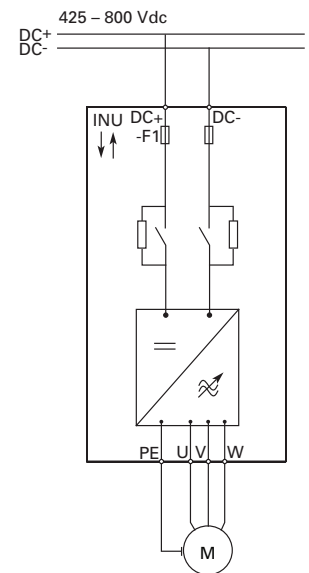

**Dimensions**

Approximate Dimensions in Inches (mm)

36

**SPA9000/SPN9000/SPI9000**

Frame	Height	Width	Depth	Weight Lbs (kg)
<b>Active Front Ends</b>				
FI9	40.6 (1030)	9.4 (239)	14.6 (372)	148 (67)
FI10	40.6 (1032)	9.4 (239)	21.7 (552)	220 (100)
FI12	40.6 (1032)	2 x 9.4 (2 x 239)	21.7 (552)	441 (200)
FI13	40.6 (1032)	27.9 (708)	21.8 (553)	674 (306)
FI14	40.6 (1032)	2 x 27.9 (2 x 708)	21.8 (553)	1348 (612)
<b>Non-Regenerative Front Ends</b>				
FI9	40.6 (1030)	9.4 (239)	14.6 (372)	148 (67)
<b>Inverter Units</b>				
FR4	11.5 (292)	5.0 (128)	7.5 (190)	11 (5)
FR6	20.4 (519)	7.7 (195)	9.3 (237)	35 (16)
FR7	23.3 (591)	9.3 (237)	10.1 (257)	64 (29)
FR8	29.8 (758)	11.4 (289)	13.5 (344)	106 (48)
FI9	40.6 (1030)	9.4 (239)	14.6 (372)	148 (67)
FI10	40.6 (1032)	9.4 (239)	21.7 (552)	220 (100)
FI12	40.6 (1032)	2 x 9.4 (2 x 239)	21.7 (552)	441 (200)
FI13	40.6 (1032)	27.9 (708)	21.8 (553)	674 (306)
FI14	40.6 (1032)	2 x 27.9 (2 x 708)	21.8 (553)	1348 (612)